

雙玥

# THE DUET

SALES BROCHURE  
售樓說明書

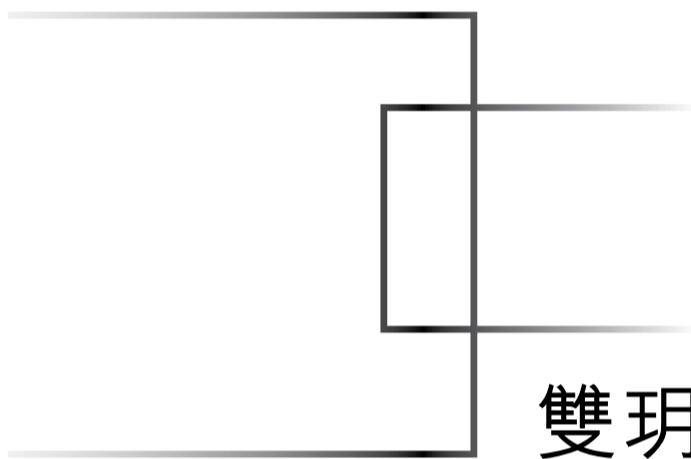



雙玥

THE DUET

# NOTES TO PURCHASERS OF FIRST-HAND RESIDENTIAL PROPERTIES

## 一手住宅物業買家須知

You are advised to take the following steps before purchasing first-hand residential properties.

### For all first-hand residential properties

#### 1. Important information

- Make reference to the materials available on the Sales of First-hand Residential Properties Electronic Platform (SRPE) ([www.srpe.gov.hk](http://www.srpe.gov.hk)) on the first-hand residential property market.
- Study the information on the website designated by the vendor for the development, including the sales brochure, price lists, documents containing the sales arrangements, and the register of transactions of a development.
- Sales brochure for a development will be made available to the general public at least 7 days immediately before a date of sale while price list and sales arrangements will be made available at least 3 days immediately before the date of sale.
- Information on transactions can be found on the register of transactions on the website designated by the vendor for the development and the SRPE.

#### 2. Fees, mortgage loan and property price

- Calculate the total expenses of the purchase, such as solicitors' fees, mortgage charges, insurance fees and stamp duties.
- Check with banks to find out if you will be able to obtain the needed mortgage loan, select the appropriate payment method and calculate the amount of the mortgage loan to ensure it is within your repayment ability.
- Check recent transaction prices of comparable properties for comparison.
- Check with the vendor or the estate agent the estimated management fee, the amount of management fee payable in advance (if any), special fund payable (if any), the amount of reimbursement of the deposits for water, electricity and gas (if any), and/or the amount of debris removal fee (if any) you have to pay to the vendor or the manager of the development.

#### 3. Price list, payment terms and other financial incentives

- Vendors may not offer to sell all the residential properties that are covered in a price list. To know which residential properties the vendors may offer to sell, pay attention to the sales arrangements which will be announced by the vendors at least 3 days before the relevant residential properties are offered to be sold.
- Pay attention to the terms of payment as set out in a price list. If there are discounts on the price, gift, or any financial advantage or benefit to be made available in connection with the purchase of the residential properties, such information will also be set out in the price list.
- If you intend to opt for any mortgage loan plans offered by financial institutions specified by the vendor, before entering into a preliminary agreement for sale and purchase (PASP), you must study the details of various mortgage loan plans<sup>1</sup> as set out in the price list concerned. If you have any questions about these mortgage loan plans, you should check with the financial institutions concerned direct before entering into a PASP.

#### 4. Property area and its surroundings

- Pay attention to the area information in the sales brochure and price list, and price per square foot/metre in the price list. According to the Residential Properties (First-hand Sales) Ordinance (Cap. 621) (the Ordinance), vendors can only present the area and price per square foot and per square metre of a residential property using saleable area. Saleable area, in relation to a residential property, means the floor area of the residential property, and includes the floor area of every one of the following to the extent that it forms part of the residential property - (i) a balcony; (ii) a utility platform; and (iii) a verandah. The saleable area excludes the area of the following which forms part of the residential property - air-conditioning plant room; bay window; cockloft; flat roof; garden; parking space; roof; stairhood; terrace and yard.
- Floor plans of all residential properties in the development have to be shown in the sales brochure. In a sales brochure, floor plans of residential properties in the development must state the external and internal dimensions of each residential property<sup>2</sup>. The external and internal dimensions of residential properties as provided in the sales brochure exclude plaster and finishes. You are advised to note this if you want to buy furniture before handing over of the residential property.
- Visit the development site and get to know the surroundings of the property (including transportation and community facilities).

Check town planning proposals and decisions which may affect the property. Take a look at the location plan, aerial photograph, outline zoning plan and cross-section plan that are provided in the sales brochure.

#### 5. Sales brochure

- Ensure that the sales brochure obtained is the latest version. According to the Ordinance, the sales brochure made available to the public should be printed or examined, or examined and revised within the previous 3 months.
- In respect of an uncompleted development, the vendor may alter the building plans (if any) whenever the vendor considers necessary. To know the latest information of an uncompleted development, keep paying attention to any revised sales brochures made available by the vendor.
- Read through the sales brochure and in particular, check the following information in the sales brochure –
  - whether there is a section on “relevant information” in the sales brochure, under which information on any matter that is known to the vendor but is not known to the general public, and is likely to materially affect the enjoyment of a residential property will be set out. Please note that information contained in a document that has been registered with the Land Registry will not be regarded as “relevant information”;
  - the cross-section plan showing a cross-section of the building in relation to every street adjacent to the building, and the level of every such street in relation to a known datum and to the level of the lowest residential floor of the building. This will help you visualize the difference in height between the lowest residential floor of a building and the street level, regardless of how that lowest residential floor is named;
  - interior and exterior fittings and finishes and appliances;
  - the basis on which management fees are shared;
  - whether individual owners have obligations or need to share the expenses for managing, operating and maintaining the public open space or public facilities inside or outside the development, and the location of the public open space or public facilities; and
  - whether individual owners have responsibility to maintain slopes.

#### 6. Government land grant and deed of mutual covenant (DMC)

- Read the Government land grant and the DMC (or the draft DMC). Information such as ownership of the rooftop and external walls can be found in the DMC. The vendor will provide copies of the Government land grant and the DMC (or the draft DMC) at the place where the sale is to take place for free inspection by prospective purchasers.
- Check the Government land grant on whether individual owners are liable to pay Government rent.
- Check the DMC on whether animals can be kept in the residential property.

#### 7. Information on Availability of Residential Properties for Selection at Sales Office

- Check with the vendor which residential properties are available for selection. If a “consumption table” is displayed by the vendor at the sales office, you may check from the table information on the progress of sale on a date of sale, including which residential properties are offered for sale at the beginning of that date of sale and which of them have been selected and sold during that date of sale.
- Do not believe in rumours about the sales condition of the development and enter into a PASP rashly.

#### 8. Register of Transactions

- Pay attention to the register of transactions for a development. A vendor must, within 24 hours after entering into a PASP with a purchaser, enter transaction information of the PASP in the register of transactions. The vendor must, within 1 working day after entering into an agreement for sale and purchase (ASP), enter transaction information of the ASP in the register of transactions. Check the register of transactions for the concerned development to learn more about the sales condition of the development.
- Never take the number of registrations of intent or cashier orders a vendor has received for the purpose of registration as an indicator of the sales volume of a development. The register of transactions for a development is the most reliable source of information from

# NOTES TO PURCHASERS OF FIRST-HAND RESIDENTIAL PROPERTIES

## 一手住宅物業買家須知

which members of the public can grasp the daily sales condition of the development.

### 9. Agreement for sale and purchase

- Ensure that the PASP and ASP include the mandatory provisions as required by the Ordinance.
- Pay attention that fittings, finishes and appliances to be included in the sale and purchase of the property are inserted in the PASP and ASP.
- Pay attention to the area plan annexed to the ASP which shows the total area which the vendor is selling to you. The total area which the vendor is selling to you is normally greater than the saleable area of the property.
- Pay attention to the vendor's right to alter the building plans (if any) for an uncompleted development. The mandatory provisions to be incorporated in an ASP for uncompleted development as required by the Ordinance include a provision requiring the vendor to notify the purchaser in writing of such alteration if the same affects in any way the property within 14 days after its having been approved by the Building Authority.
- A preliminary deposit of 5% of the purchase price is payable by you to the owner (i.e. the seller) on entering into a PASP.
- If you do not execute the ASP within 5 working days (working day means a day that is not a general holiday or a Saturday or a black rainstorm warning day or gale warning day) after entering into the PASP, the PASP is terminated, the preliminary deposit (i.e. 5% of the purchase price) is forfeited, and the owner (i.e. the seller) does not have any further claim against you for not executing the ASP.
- If you execute the ASP within 5 working days after the signing of the PASP, the owner (i.e. the seller) must execute the ASP within 8 working days after entering into the PASP.
- The deposit should be made payable to the solicitors' firm responsible for stakeholding purchasers' payments for the property.

### 10. Expression of intent of purchasing a residential property

- Note that vendors (including their authorized representative(s)) should not seek or accept any specific or general expression of intent of purchasing any residential property before the relevant price lists for such properties are made available to the public. You therefore should not make such an offer to the vendors or their authorized representative(s).
- Note that vendors (including their authorized representative(s)) should not seek or accept any specific expression of intent of purchasing a particular residential property before the sale of the property has commenced. You therefore should not make such an offer to the vendors or their authorized representative(s).

### 11. Appointment of estate agent

- Note that if the vendor has appointed one or more than one estate agents to act in the sale of any specified residential property in the development, the price list for the development must set out the name of all the estate agents so appointed as at the date of printing of the price list.
- You may appoint any estate agent (not necessarily from those estate agency companies appointed by the vendor) to act in the purchase of any specified residential property in the development, and may also not appoint any estate agent to act on your behalf.
- Before you appoint an estate agent to look for a property, you should –
  - find out whether the agent will act on your behalf only. If the agent also acts for the vendor, he/she may not be able to protect your best interests in the event of a conflict of interest;
  - find out whether any commission is payable by you to the estate agent and, if so, its amount and the time of payment; and
  - note that only licensed estate agents or salespersons may accept your appointment. If in doubt, you should request the estate agent or salesperson to produce his/her Estate Agent Card, or check the Licence List on the Estate Agents Authority website: [www.eaa.org.hk](http://www.eaa.org.hk).

### 12. Appointment of solicitor

- Consider appointing your own solicitor to protect your interests. If the solicitor also acts for the vendor, he/she may not be able to protect your best interests in the event of a conflict of interest.
- Compare the charges of different solicitors.

### For first-hand uncompleted residential properties

#### 13. Pre-sale Consent

- For uncompleted residential property under the Lands Department Consent Scheme, seek confirmation from the vendor whether the "Pre-sale Consent" has been issued by the Lands Department for the development.

#### 14. Show flats

- While the vendor is not required to make any show flat available for viewing by prospective purchasers or the general public, if the vendor wishes to make available show flats of a specified residential property, the vendor must first of all make available an unmodified show flat of that residential property and that, having made available such unmodified show flat, the vendor may then make available a modified show flat of that residential property. In this connection, the vendor is allowed to make available more than one modified show flat of that residential property.
- If you visit the show flats, you should always look at the unmodified show flats for comparison with the modified show flats. That said, the Ordinance does not restrict the discretion of the vendor in arranging the sequence of the viewing of unmodified and modified show flats.
- Sales brochure of the development should have been made available to the public when the show flat is made available for viewing. You are advised to get a copy of the sales brochure and make reference to it when viewing the show flats.
- You may take measurements in modified and unmodified show flats, and take photographs or make video recordings of unmodified show flats, subject to reasonable restriction(s) which may be set by the vendor for ensuring safety of the persons viewing the show flat.

### For first-hand uncompleted residential properties and completed residential properties pending compliance

#### 15. Estimated material date and handing over date

- Check the estimated material date<sup>3</sup> for the development in the sales brochure.
  - The estimated material date for a development in the sales brochure is not the same as the date on which a residential property is handed over to purchaser. The latter is normally later than the former. However, the handing over date may be earlier than the estimated material date set out in the sales brochure in case of earlier completion of the development.
- Handing over date
  - The mandatory provisions to be incorporated in an ASP as required by the Ordinance include a provision requiring the vendor to apply in writing for an Occupation Document/a Certificate of Compliance or the Director of Lands' Consent to Assign (as the case may be) in respect of the development within 14 days after the estimated material date as stipulated in the ASP.
    - For development subject to the Lands Department Consent Scheme, the vendor is required to notify the purchaser in writing that the vendor is in a position validly to assign the property within one month after the issue of the Certificate of Compliance or the Consent to Assign, whichever first happens; or
    - For development not subject to the Lands Department Consent Scheme, the vendor is required to notify the purchaser in writing that the vendor is in a position validly to assign the property within 6 months after the issue of the Occupation Document including Occupation Permit.
  - The mandatory provisions to be incorporated in an ASP as required by the Ordinance include a provision requiring completion of the sale and purchase within 14 days after the date of the notification aforesaid. Upon completion, the vendor shall arrange handover of the property to the purchaser.
- Authorized Person (AP) may grant extension(s) of time for completion of the development beyond the estimated material date.
  - The mandatory provisions to be incorporated in an ASP as required by the Ordinance include a provision that the AP of a development may grant an extension of time for completion of the development beyond the estimated material date having regard to delays caused exclusively by any one or more of the following reasons:

# NOTES TO PURCHASERS OF FIRST-HAND RESIDENTIAL PROPERTIES

## 一手住宅物業買家須知

- strike or lock-out of workmen;
- riots or civil commotion;
- force majeure or Act of God;
- fire or other accident beyond the vendor's control;
- war; or
- inclement weather.

- The AP may grant more than once such an extension of time depending on the circumstances. That means handover of the property may be delayed.
- The mandatory provisions to be incorporated in an ASP as required by the Ordinance also include a provision requiring the vendor to, within 14 days after the issue of an extension of time granted by the AP, furnish the purchaser with a copy of the relevant certificate of extension.

- Ask the vendor if there are any questions on handing over date.

### For first-hand completed residential properties

#### 16. Vendor's information form

- Ensure that you obtain the "vendor's information form(s)" printed within the previous 3 months in relation to the residential property/properties you intend to purchase.

#### 17. Viewing of property

- Ensure that, before you purchase a residential property, you are arranged to view the residential property that you would like to purchase or, if it is not reasonably practicable to view the property in question, a comparable property in the development, unless you agree in writing that the vendor is not required to arrange such a comparable property for viewing for you. You are advised to think carefully before signing any waiver.
- You may take measurements, take photographs or make video recordings of the property, unless the property is held under a tenancy or reasonable restriction(s) is/are needed to ensure safety of the persons viewing the property.

For complaints and enquiries relating to the sales of first-hand residential properties by the vendors which the Ordinance applies, please contact the Sales of First-hand Residential Properties Authority –

Website : [www.srpa.gov.hk](http://www.srpa.gov.hk)  
Telephone : 2817 3313  
Email : [enquiry\\_srpa@hd.gov.hk](mailto:enquiry_srpa@hd.gov.hk)  
Fax : 2219 2220

#### Other useful contacts:

##### Consumer Council

Website : [www.consumer.org.hk](http://www.consumer.org.hk)  
Telephone : 2929 2222  
Email : [cc@consumer.org.hk](mailto:cc@consumer.org.hk)  
Fax : 2856 3611

##### Estate Agents Authority

Website : [www.eaa.org.hk](http://www.eaa.org.hk)  
Telephone : 2111 2777  
Email : [enquiry@eaa.org.hk](mailto:enquiry@eaa.org.hk)  
Fax : 2598 9596

##### Real Estate Developers Association of Hong Kong

Telephone : 2826 0111  
Fax : 2845 2521

Sales of First-hand Residential Properties Authority  
March 2023

<sup>1</sup> The details of various mortgage loan plans include the requirements for mortgagors on minimum income level, the loan limit under the first mortgage and second mortgage, the maximum loan repayment period, the change of mortgage interest rate throughout the entire repayment period, and the payment of administrative fees.

<sup>2</sup> According to section 10(2)(d) in Part 1 of Schedule 1 to the Ordinance, each of the floor plans of the residential properties in the development in the sales brochure must state the following –  
(i) the external dimensions of each residential property;  
(ii) the internal dimensions of each residential property;  
(iii) the thickness of the internal partitions of each residential property;  
(iv) the external dimensions of individual compartments in each residential property.

According to section 10(3) in Part 1 of Schedule 1 to the Ordinance, if any information required by section 10(2)(d) in Part 1 of Schedule 1 to the Ordinance is provided in the approved building plans for the development, a floor plan must state the information as so provided.

<sup>3</sup> Generally speaking, "material date" means the date on which the conditions of the land grant are complied with in respect of the development, or the date on which the development is completed in all respects in compliance with the approved building plans or the conditions subject to which the certificate of exemption is issued. For details, please refer to section 2 of the Ordinance.

# NOTES TO PURCHASERS OF FIRST-HAND RESIDENTIAL PROPERTIES

## 一手住宅物業買家須知

您在購置一手住宅物業之前，應留意下列事項：

### 適用於所有一手住宅物業

#### 1. 重要資訊

- 瀏覽一手住宅物業銷售資訊網(下稱「銷售資訊網」)(網址:www.srpe.gov.hk)，參考「銷售資訊網」內有關一手住宅物業的市場資料。
- 閱覽賣方就該發展項目所指定的互聯網網站內的有關資訊，包括售樓說明書、價單、載有銷售安排的文件，及成交紀錄冊。
- 發展項目的售樓說明書，會在該項目的出售日期前最少七日向公眾發布，而有關價單和銷售安排，亦會在該項目的出售日期前最少三日公布。
- 在賣方就有關發展項目所指定的互聯網網站，以及「銷售資訊網」內，均載有有關物業成交資料的成交紀錄冊，以供查閱。

#### 2. 費用、按揭貸款和樓價

- 計算置業總開支，包括律師費、按揭費用、保險費，以及印花稅。
- 向銀行查詢可否取得所需的按揭貸款，然後選擇合適的還款方式，並小心計算按揭貸款金額，以確保貸款額沒有超出本身的負擔能力。
- 查閱同類物業最近的成交價格，以作比較。
- 向賣方或地產代理瞭解，您須付予賣方或該發展項目的管理人的預計的管理費、管理費上期金額(如有)、特別基金金額(如有)、補還的水、電力及氣體按金(如有)，以及/或清理廢料的費用(如有)。

#### 3. 價單、支付條款，以及其他財務優惠

- 賣方未必會把價單所涵蓋的住宅物業悉數推售，因此應留意有關的銷售安排，以了解賣方會推售的住宅物業為何。賣方會在有關住宅物業推售日期前最少三日公布銷售安排。
- 留意價單所載列的支付條款。倘買家可就購置有關住宅物業而連帶獲得價格折扣、贈品，或任何財務優惠或利益，上述資訊亦會在價單內列明。
- 如您擬選用由賣方指定的財務機構提供的各類按揭貸款計劃，在簽訂臨時買賣合約前，應先細閱有關價單內列出的按揭貸款計劃資料<sup>1</sup>。如就該些按揭貸款計劃的詳情有任何疑問，應在簽訂臨時買賣合約前，直接向有關財務機構查詢。

#### 4. 物業的面積及四周環境

- 留意載於售樓說明書和價單內的物業面積資料，以及載於價單內的每平方呎/每平方米售價。根據《一手住宅物業銷售條例》(第621章)(下稱「條例」)，賣方只可以實用面積表達住宅物業的面積和每平方呎及平方米的售價。就住宅物業而言，實用面積指該住宅物業的樓面面積，包括在構成該物業的一部分的範圍內的以下每一項目的樓面面積：(i) 露台；(ii) 工作平台；以及 (iii) 陽台。實用面積並不包括空調機房、窗台、閣樓、平台、花園、停車位、天台、梯屋、前庭及庭院的每一項目的面積，即使該些項目構成該物業的一部分的範圍。
- 售樓說明書必須顯示發展項目中所有住宅物業的樓面平面圖。在售樓說明書所載有關發展項目中住宅物業的每一份樓面平面圖，均須述明每個住宅物業的外部及內部尺寸<sup>2</sup>。售樓說明書所提供有關住宅物業外部及內部的尺寸，不會把批盪和裝飾物料包括在內。買家收樓前如欲購置家具，應留意這點。
- 親臨發展項目的所在地實地視察，以了解有關物業的四周環境(包括交通和社區設施)；亦應查詢有否任何城市規劃方案和議決，會對有關的物業造成影響；參閱載於售樓說明書內的位置圖、鳥瞰照片、分區計劃大綱圖，以及橫截面圖。

#### 5. 售樓說明書

- 確保所取得的售樓說明書屬最新版本。根據條例，提供予公眾的售樓說明書必須是在之前的三個月之內印製或檢視、或檢視及修改。

- 如屬未落成發展項目，賣方在認為有需要時可改動建築圖則(如有的話)，因此應留意由賣方提供的任何經修改的售樓說明書，以了解有關未落成發展項目的最新資料。

- 閱覽售樓說明書，並須特別留意以下資訊：

- 售樓說明書內有否關於「有關資料」的部分，列出賣方知悉但並非為一般公眾人士所知悉，關於相當可能對享用有關住宅物業造成重大影響的事宜的資料。請注意，已在土地註冊處註冊的文件，其內容不會被視為「有關資料」；
- 橫截面圖會顯示有關建築物相對毗連該建築物的每條街道的橫截面，以及每條上述街道與已知基準面和該建築物最低的一層住宅樓層的水平相對的水平。橫截面圖能以圖解形式，顯示出建築物最低一層住宅樓層和街道水平的高低差距，不論該最低住宅樓層以何種方式命名；
- 室內和外部的裝置、裝修物料和設備；
- 管理費按甚麼基準分擔；
- 小業主有否責任或需要分擔管理、營運或維持有關發展項目以內或以外的公眾休憩用地或公共設施的開支，以及有關公眾休憩用地或公共設施的位置；以及
- 小業主是否須要負責維修斜坡。

#### 6. 政府批地文件和公契

- 閱覽政府批地文件和公契(或公契擬稿)。公契內載有天台和外牆業權等相關資料。賣方會在售樓處提供政府批地文件和公契(或公契擬稿)的複本，供準買家免費閱覽。

- 留意政府批地文件內所訂明小業主是否須要負責支付地稅。

- 留意公契內訂明有關物業內可否飼養動物。

#### 7. 售樓處內有關可供揀選住宅物業的資料

- 向賣方查詢清楚有哪些一手住宅物業可供揀選。若賣方在售樓處內展示「消耗表」，您可從該「消耗表」得悉在每個銷售日的銷售進度資料，包括在該個銷售日開始時有哪些住宅物業可供出售，以及在該個銷售日內有哪些住宅物業已獲揀選及售出。

- 切勿隨便相信有關發展項目銷情的傳言，倉卒簽立臨時買賣合約。

#### 8. 成交紀錄冊

- 留意發展項目的成交紀錄冊。賣方須於臨時買賣合約訂立後的24小時內，於紀錄冊披露該臨時買賣合約的資料，以及於買賣合約訂立後一個工作天內，披露該買賣合約的資料。您可透過成交紀錄冊得悉發展項目的銷售情況。

- 切勿將賣方接獲用作登記的購樓意向書或本票的數目視為銷情指標。發展項目的成交紀錄冊才是讓公眾掌握發展項目每日銷售情況的最可靠資料來源。

#### 9. 買賣合約

- 確保臨時買賣合約和買賣合約包含條例所規定的強制性條文。
- 留意有關物業買賣交易所包括的裝置、裝修物料和設備，須在臨時買賣合約和買賣合約上列明。

- 留意夾附於買賣合約的圖則。該圖則會顯示所有賣方售予您的物業面積，而該面積通常較該物業的實用面積為大。

- 留意賣方有權改動未落成發展項目的建築圖則(如有的話)。如屬未落成發展項目，條例規定物業的買賣合約須載有強制性條文，列明如有關改動在任何方面對該物業造成影響，賣方須在改動獲建築事務監督批准後的14日內，將該項改動以書面通知買家。

- 訂立臨時買賣合約時，您須向擁有人(即賣方)支付樓價5%的臨時訂金。

# NOTES TO PURCHASERS OF FIRST-HAND RESIDENTIAL PROPERTIES

## 一手住宅物業買家須知

- 如您在訂立臨時買賣合約後**五個工作日**(工作日指並非公眾假日、星期六、黑色暴雨警告日或烈風警告日的日子)之內,沒有簽立買賣合約,該臨時買賣合約即告終止,有關臨時訂金(即樓價的5%)會被沒收,而擁有人(即賣方)不得因您沒有簽立買賣合約而對您提出進一步申索。
- 在訂立臨時買賣合約後的五個工作日之內,倘您簽立買賣合約,則擁有人(即賣方)必須在訂立該臨時買賣合約後的八個工作日之內簽立買賣合約。
- 有關的訂金,應付予負責為所涉物業擔任保證金保存人的律師事務所。

### 10. 表達購樓意向

- 留意在賣方(包括其獲授權代表)就有關住宅物業向公眾提供價單前,賣方不得尋求或接納任何對有關住宅物業的購樓意向(不論是否屬明確選擇購樓意向)。因此您不應向賣方或其授權代表提出有關意向。
- 留意在有關住宅物業的銷售開始前,賣方(包括其獲授權代表)不得尋求或接納任何對該物業的有明確選擇購樓意向。因此您不應向賣方或其授權代表提出有關意向。

### 11. 委託地產代理

- 留意倘賣方委任一個或多於一個地產代理,以協助銷售其發展項目內任何指明住宅物業,該發展項目的價單必須列明在價單印刷日期當日所有獲委任為地產代理的姓名/名稱。
- 您可委託任何地產代理(不一定是賣方所指定的地產代理),以協助您購置發展項目內任何指明住宅物業;您亦可不委託任何地產代理。
- 委託地產代理以物色物業前,您應該 —
  - 了解該地產代理是否只代表您行事。該地產代理若同時代表賣方行事,倘發生利益衝突,未必能夠保障您的最大利益;
  - 了解您須否支付佣金予該地產代理。若須支付,有關的佣金金額和支付日期為何;以及
  - 留意只有持牌地產代理或營業員才可以接受您的委託。如有疑问,應要求該地產代理或營業員出示其「地產代理證」,或瀏覽地產代理監管局的網頁(網址:www.eaa.org.hk),查閱牌照目錄。

### 12. 委聘律師

- 考慮自行委聘律師,以保障您的利益。該律師若同時代表賣方行事,倘發生利益衝突,未必能夠保障您的最大利益。
- 比較不同律師的收費。

### 適用於一手未落成住宅物業

#### 13. 預售樓花同意書

- 洽購地政總署「預售樓花同意方案」下的未落成住宅物業時,應向賣方確認地政總署是否已就該發展項目批出「預售樓花同意書」。

#### 14. 示範單位

- 賣方不一定須設置示範單位供準買家或公眾參觀,但賣方如為某指明住宅物業設置示範單位,必須首先設置該住宅物業的無改動示範單位,才可設置該住宅物業的經改動示範單位,並可以就該住宅物業設置多於一個經改動示範單位。
- 參觀示範單位時,務必視察無改動示範單位,以便與經改動示範單位作出比較。然而,條例並沒有限制賣方安排參觀無改動示範單位及經改動示範單位的先後次序。
- 賣方設置示範單位供公眾參觀時,應已提供有關發展項目的售樓說明書。因此,緊記先行索取售樓說明書,以便在參觀示範單位時參閱相關資料。

- 您可以在無改動示範單位及經改動示範單位中進行量度,並在無改動示範單位內拍照或拍攝影片,惟在確保示範單位參觀者人身安全的前提下,賣方可能會設定合理的限制。

### 適用於一手未落成住宅物業及尚待符合條件的已落成住宅物業

#### 15. 預計關鍵日期及收樓日期

- 查閱售樓說明書中有關發展項目的預計關鍵日期<sup>3</sup>。
  - 售樓說明書中有關發展項目的預計關鍵日期並不同買家的「收樓日期」。買家的「收樓日期」一般會較發展項目的預計關鍵日期遲。然而,假若發展項目比預期早落成,「收樓日期」可能會較售樓說明書列出的預計關鍵日期為早。
- 收樓日期
  - 條例規定買賣合約須載有強制性條文,列明賣方須於買賣合約內列出的預計關鍵日期後的14日內,以書面為發展項目申請佔用文件、合格證明書,或地政總署署長的轉讓同意(視屬何種情況而定)。
    - 如發展項目屬地政總署預售樓花同意方案所規管,賣方須在合格證明書或地政總署署長的轉讓同意發出後的一個月內(以較早者為準),就賣方有能力有效地轉讓有關物業一事,以書面通知買家;或
    - 如發展項目並非屬地政總署預售樓花同意方案所規管,賣方須在佔用文件(包括佔用許可證)發出後的六個月內,就賣方有能力有效地轉讓有關物業一事,以書面通知買家。
  - 條例規定買賣合約須載有強制性條文,列明有關物業的買賣須於賣方發出上述通知的日期的14日內完成。有關物業的買賣完成後,賣方將安排買家收樓事宜。
- 認可人士可批予在預計關鍵日期之後完成發展項目
  - 條例規定買賣合約須載有強制性條文,列明發展項目的認可人士可以在顧及純粹由以下一個或多於一個原因所導致的延遲後,批予在預計關鍵日期之後,完成發展項目:
    - 工人罷工或封閉工地;
    - 暴動或內亂;
    - 不可抗力或天災;
    - 火警或其他賣方所不能控制的意外;
    - 戰爭;或
    - 惡劣天氣。
  - 發展項目的認可人士可以按情況,多於一次批予延後預計關鍵日期以完成發展項目,即收樓日期可能延遲。
  - 條例規定買賣合約須載有強制性條文,列明賣方須於認可人士批予延期後的14日內,向買家提供有關延期證明書的文本。
- 如對收樓日期有任何疑問,可向賣方查詢。

### 適用於一手已落成住宅物業

#### 16. 賣方資料表格

- 確保取得最近三個月內印製有關您擬購買的一手已落成住宅物業的「賣方資料表格」。

#### 17. 參觀物業

- 購置住宅物業前,確保已獲安排參觀您打算購置的住宅物業。倘參觀有關物業並非合理地切實可行,則應參觀與有關物業相若的物業,除非您以書面同意賣方無須開放與有關物業相若的物業供您參觀。您應仔細考慮,然後才決定是否簽署豁免上述規定的書面同意。
- 除非有關物業根據租約持有,或為確保物業參觀者的人身安全而須設定合理限制,您可以對該物業進行量度、拍照或拍攝影片。

# NOTES TO PURCHASERS OF FIRST-HAND RESIDENTIAL PROPERTIES

## 一手住宅物業買家須知

---

任何與賣方銷售受條例所規管的一手住宅物業有關的投訴和查詢，請與一手住宅物業銷售監管局聯絡。

網址：[www.srpa.gov.hk](http://www.srpa.gov.hk)  
電話：2817 3313  
電郵：[enquiry\\_srpa@hd.gov.hk](mailto:enquiry_srpa@hd.gov.hk)  
傳真：2219 2220

### 其他相關聯絡資料：

#### 消費者委員會

網址：[www.consumer.org.hk](http://www.consumer.org.hk)  
電話：2929 2222  
電郵：[cc@consumer.org.hk](mailto:cc@consumer.org.hk)  
傳真：2856 3611

#### 地產代理監管局

網址：[www.eaa.org.hk](http://www.eaa.org.hk)  
電話：2111 2777  
電郵：[enquiry@eaa.org.hk](mailto:enquiry@eaa.org.hk)  
傳真：2598 9596

#### 香港地產建設商會

電話：2826 0111  
傳真：2845 2521

一手住宅物業銷售監管局  
2023年3月

---

<sup>1</sup> 按揭貸款計劃的資料包括有關按揭貸款計劃對借款人的最低收入的要求、就第一按揭連同第二按揭可獲得的按揭貸款金額上限、最長還款年期、整個還款期內的按揭利率變化，以及申請人須繳付的手續費。

<sup>2</sup> 根據條例附表1第1部第10(2)(d)條述明，售樓說明書內顯示的發展項目中的住宅物業的每一份樓面平面圖須述明以下各項—

- (i) 每個住宅物業的外部尺寸；
- (ii) 每個住宅物業的內部尺寸；
- (iii) 每個住宅物業的內部間隔的厚度；
- (iv) 每個住宅物業內個別分隔室的外部尺寸。

根據條例附表1第1部第10(3)條，如有關發展項目的經批准的建築圖則，提供條例附表1第1部第10(2)(d)條所規定的資料，樓面平面圖須述明如此規定的該資料。

<sup>3</sup> 一般而言，「關鍵日期」指該項目符合批地文件的條件的日期，或該項目在遵照經批准的建築圖則的情況下或按照豁免證明書的發出的條件在各方面均屬完成的日期。有關詳情請參閱條例第2條。

# INFORMATION ON THE DEVELOPMENT

## 發展項目的資料

---

**Name of the Development**

The Duet

**發展項目名稱**

雙玥

**Name of the street at which the Development is situated and the street number allocated by the Commissioner of Rating and Valuation for the purpose of distinguishing the Development**

No. 9, 11 Lok Chui Street

**發展項目所位於的街道的名稱及差餉物業估價署署長為識別發展項目的目的而編配的門牌號數**

樂翠街9, 11號

**Total number of houses**

There are 2 houses in the Development.

**獨立屋的總數**

發展項目共有2座獨立屋

**House numbering**

House 1

House 2

**洋房的門牌號數**

1 號洋房

2 號洋房

**Omitted house number**

Not applicable

**被略去的門牌號數**

不適用

# INFORMATION ON VENDOR AND OTHERS INVOLVED IN THE DEVELOPMENT

## 賣方及有參與發展項目的其他人的資料

---

### Vendor

Treasure Chest Limited  
Trade Globalize Limited

### 賣方

Treasure Chest Limited  
Trade Globalize Limited

### Holding companies of the Vendor

Applicable to Treasure Chest Limited only:  
Tycoon Gather Limited, Trendy Forever Limited  
Applicable to Trade Globalize Limited only:  
Tycoon Gather Limited, Trendy Forever Limited

### 賣方之控權公司

僅適用於Treasure Chest Limited：  
Tycoon Gather Limited，Trendy Forever Limited  
僅適用於Trade Globalize Limited：  
Tycoon Gather Limited，Trendy Forever Limited

### Authorized Person for the Development

Mr. Wong Min Hon, Thomas

### 發展項目的認可人士

黃明康先生

### The firm or corporation of which an Authorized Person for the Development is a proprietor, director or employee in his or her professional capacity

Wong Tung & Partners Limited

### 發展項目的認可人士以其專業身分擔任經營人、董事或僱員的商號或法團

王董建築師事務有限公司

### Building contractor for the Development

Tysan Building Construction Company Limited

### 發展項目的承建商

泰昇建築工程有限公司

### The firm of solicitors acting for the Owners in relation to the sale of the residential properties in the Development

Baker & McKenzie

### 就發展項目中的住宅物業的出售而代表擁有人行事的律師事務所

貝克·麥堅時律師事務所

### Authorized institution that has made a loan, or has undertaken to provide finance, for the construction of the Development

Shanghai Commercial Bank Limited

### 已為發展項目的建造提供貸款或已承諾為發展項目的建造提供融資的認可機構

上海商業銀行

### Any other person who has made a loan for the construction of the Development

Not applicable

### 已為發展項目的建造提供貸款的任何其他人士

不適用

## RELATIONSHIP BETWEEN PARTIES INVOLVED IN THE DEVELOPMENT 有參與發展項目的各方的關係

(a)	The Vendor or a building contractor for the Development is an individual, and that Vendor or contractor is an immediate family member of an Authorized Person for the Development; 賣方或有關發展項目的承建商屬個人，並屬該項目的認可人士的家人；	Not applicable 不適用
(b)	The Vendor or a building contractor for the Development is a partnership, and a partner of that Vendor or contractor is an immediate family member of such an Authorized Person; 賣方或該項目的承建商屬合夥，而該賣方或承建商的合夥人屬上述認可人士的家人；	Not applicable 不適用
(c)	The Vendor or a building contractor for the Development is a corporation, and a director or the secretary of that Vendor or contractor (or a holding company of that Vendor) is an immediate family member of such an Authorized Person; 賣方或該項目的承建商屬法團，而該賣方或承建商(或該賣方的控權公司)的董事或秘書屬上述認可人士的家人；	No 否
(d)	The Vendor or a building contractor for the Development is an individual, and that Vendor or contractor is an immediate family member of an associate of such an Authorized Person; 賣方或該項目的承建商屬個人，並屬上述認可人士的有聯繫人士的家人；	Not applicable 不適用
(e)	The Vendor or a building contractor for the Development is a partnership, and a partner of that Vendor or contractor is an immediate family member of an associate of such an Authorized Person; 賣方或該項目的承建商屬合夥，而該賣方或承建商的合夥人屬上述認可人士的有聯繫人士的家人；	Not applicable 不適用
(f)	The Vendor or a building contractor for the Development is a corporation, and a director or the secretary of that Vendor or contractor (or a holding company of that Vendor) is an immediate family member of an associate of such an Authorized Person; 賣方或該項目的承建商屬法團，而該賣方或承建商(或該賣方的控權公司)的董事或秘書屬上述認可人士的有聯繫人士的家人；	No 否
(g)	The Vendor or a building contractor for the Development is an individual, and that Vendor or contractor is an immediate family member of a proprietor of a firm of solicitors acting for the owner in relation to the sale of residential properties in the Development; 賣方或該項目的承建商屬個人，並屬就該項目內的住宅物業的出售代表擁有人行事的律師事務所行事的經營人的家人；	Not applicable 不適用
(h)	The Vendor or a building contractor for the Development is a partnership, and a partner of that Vendor or contractor is an immediate family member of a proprietor of a firm of solicitors acting for the owner in relation to the sale of residential properties in the Development; 賣方或該項目的承建商屬合夥，而該賣方或承建商的合夥人屬就該項目內的住宅物業的出售代表擁有人行事的律師事務所行事的經營人的家人；	Not applicable 不適用
(i)	The Vendor or a building contractor for the Development is a corporation, and a director or the secretary of that Vendor or contractor (or a holding company of that Vendor) is an immediate family member of a proprietor of such a firm of solicitors; 賣方或該項目的承建商屬法團，而該賣方或承建商(或該賣方的控權公司)的董事或秘書屬上述律師事務所的經營人的家人；	No 否
(j)	The Vendor, a holding company of the Vendor, or a building contractor for the Development, is a private company, and an Authorized Person for the Development, or an associate of such an Authorized Person, holds at least 10% of the issued shares in that Vendor, holding company or contractor; 賣方、賣方的控權公司或有關發展項目的承建商屬私人公司，而該項目的認可人士或該認可人士的有聯繫人士持有該賣方、控權公司或承建商最少10%的已發行股份；	No 否
(k)	The Vendor, a holding company of the Vendor, or a building contractor for the Development, is a listed company, and such an Authorized Person, or such an associate, holds at least 1% of the issued shares in that Vendor, holding company or contractor; 賣方、賣方的控權公司或該項目的承建商屬上市公司，而上述認可人士或上述有聯繫人士持有該賣方、控權公司或承建商最少1%的已發行股份；	No 否
(l)	The Vendor or a building contractor for the Development is a corporation, and such an Authorized Person, or such an associate, is an employee, director or secretary of that Vendor or contractor or of a holding company of that Vendor; 賣方或該項目的承建商屬法團，而上述認可人士或上述有聯繫人士屬該賣方、承建商或該賣方的控權公司的僱員、董事或秘書；	Not applicable 不適用
(m)	The Vendor or a building contractor for the Development is a partnership, and such an Authorized Person, or such an associate, is an employee of that Vendor or contractor; 賣方或該項目的承建商屬合夥，而上述認可人士或上述有聯繫人士屬該賣方或承建商的僱員；	Not applicable 不適用
(n)	The Vendor, a holding company of the Vendor, or a building contractor for the Development, is a private company, and a proprietor of a firm of solicitors acting for the owner in relation to the sale of residential properties in the Development holds at least 10% of the issued shares in that Vendor, holding company or contractor; 賣方、賣方的控權公司或該項目的承建商屬私人公司，而就該項目中的住宅物業的出售而代表擁有人行事的律師事務所的經營人持有該賣方、控權公司或承建商最少10%的已發行股份；	No 否
(o)	The Vendor, a holding company of the Vendor, or a building contractor for the Development, is a listed company, and a proprietor of such a firm of solicitors holds at least 1% of the issued shares in that Vendor, holding company or contractor; 賣方、賣方的控權公司或該項目的承建商屬上市公司，而上述律師事務所的經營人持有該賣方、控權公司或承建商最少1%的已發行股份；	No 否
(p)	The Vendor or a building contractor for the Development is a corporation, and a proprietor of such a firm of solicitors is an employee, director or secretary of that Vendor or contractor or of a holding company of that Vendor; 賣方或該項目的承建商屬法團，而上述律師事務所的經營人屬該賣方或承建商或該賣方的控權公司的僱員、董事或秘書；	No 否

**RELATIONSHIP BETWEEN PARTIES INVOLVED IN THE DEVELOPMENT**  
**有參與發展項目的各方的關係**

(q)	<p>The Vendor or a building contractor for the Development is a partnership, and a proprietor of such a firm of solicitors is an employee of that Vendor or contractor;          賣方或該項目的承建商屬合夥，而上述律師事務所的經營人屬該賣方或承建商的僱員；</p>	<p>Not applicable          不適用</p>
(r)	<p>The Vendor or a building contractor for the Development is a corporation, and the corporation of which an Authorized Person for the Development is a director or employee in his or her professional capacity is an associate corporation of that Vendor or contractor or of a holding company of that Vendor;          賣方或該項目的承建商屬法團，而該項目的認可人士以其專業身分擔任董事或僱員的法團為該賣方或承建商或該賣方的控權公司的有聯繫法團；</p>	<p>No          否</p>
(s)	<p>The Vendor or a building contractor for the Development is a corporation, and that contractor is an associate corporation of that Vendor or of a holding company of that Vendor.          賣方或該項目的承建商屬法團，而該承建商屬該賣方或該賣方的控權公司的有聯繫法團。</p>	<p>No          否</p>

## INFORMATION ON DESIGN OF THE DEVELOPMENT

### 發展項目的設計資料

There are curtain walls forming part of the enclosing walls for the Development. The range of thickness of curtain walls of each building is 200mm.  
發展項目有構成圍封牆的一部分的幕牆。每幢建築物的幕牆的厚度範圍為200毫米。

#### Schedule of Total Area of curtain wall of Each Residential Property 每個住宅物業的幕牆總面積表

House 洋房	Total Area of curtain wall of each Residential Property (sq.m) 每個住宅物業的幕牆的總面積 (平方米)
House 1 1 號洋房	13.514
House 2 2 號洋房	10.778

There is no non-structural prefabricated external wall forming part of the enclosing walls for the Development.  
發展項目沒有構成圍封牆的一部分的非結構的預製外牆。

## INFORMATION ON PROPERTY MANAGEMENT 物業管理的資料

---

**The person appointed as the Manager under the deed of mutual covenant that has been executed:**  
Savills Property Management Limited

根據已簽立的公契獲委任為發展項目的管理人：  
第一太平戴維斯物業管理有限公司

# LOCATION PLAN OF THE DEVELOPMENT 發展項目的所在位置圖

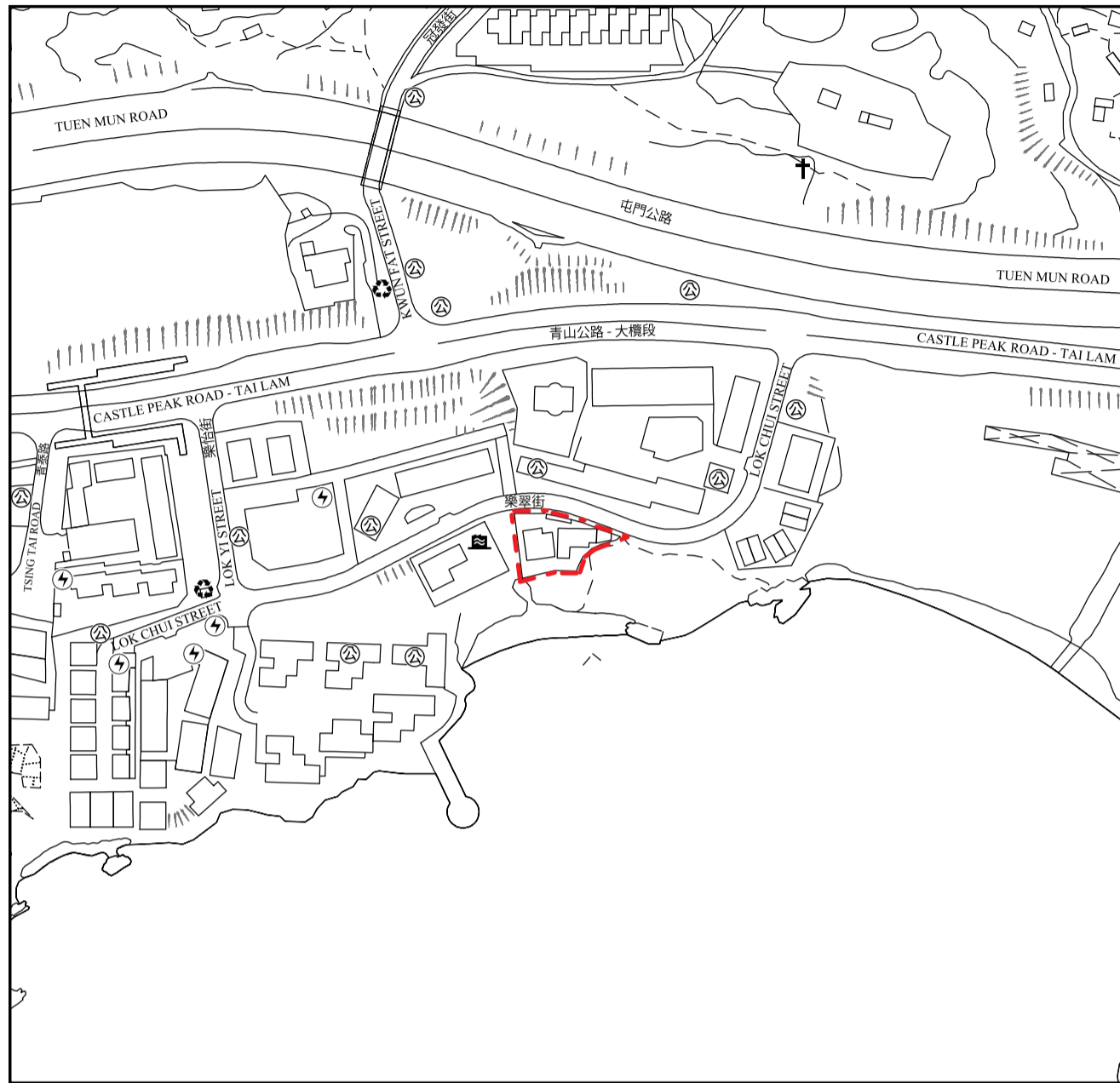

Location of Development  
發展項目的位置

SCALE   
比例 0 250M/米

## NOTATION 圖例

Power plant (including electricity sub-stations)  
發電廠 (包括電力分站)

Public utility installation  
公用事業設施裝置

Refuse collection point  
垃圾收集站

Cemetery  
墳場

Sewage treatment works and facilities  
污水處理廠及設施

The location plan is adopted from part of the Survey Sheet No. T6-SW-C and T6-SW-D from Survey and Mapping Office of Lands Department, with adjustments where necessary. The Map is/are provided by the CSDI Portal and intellectual property rights are owned by the Government of the HKSAR.

Remark:  
Due to technical reasons, the location plan has shown more than the area required under the Residential Properties (First-hand Sales) Ordinance.

此所在位置圖乃參考地政總署測繪處的測繪圖編號T6-SW-C及T6-SW-D，經修正處理。

地圖由空間數據共享平台提供，香港特別行政區政府為知識產權擁有人。

備註：  
因技術性問題，此位置圖所顯示的範圍超過《一手住宅物業銷售條例》的規定。

## AERIAL PHOTOGRAPH OF THE DEVELOPMENT 發展項目的鳥瞰照片



● Location of the Development  
發展項目的位置

Aerial Photograph is provided by the CSDI Portal and intellectual property rights are owned by the Government of the HKSAR.

Survey and Mapping Office, Lands Department, the Government of HKSAR  
© Copyright reserved - reproduction by permission only.

Adopted from part of the aerial photograph taken by the Survey and Mapping Office of the Lands Department at a flying height of 6,900 feet, Photo No. E263216C, date of Flight: 14 September 2025.

鳥瞰照片由空間數據共享平台提供，香港特別行政區政府為知識產權擁有人。

香港特別行政區政府地政總署測繪處版權所有，未經許可，不得複製。

摘錄自地政總署測繪處在6,900呎飛行高度拍攝之鳥瞰照片，編號為E263216C，飛行日期：2025年9月14日。

### Remarks:

Due to technical reasons, this aerial photograph has shown more than the area required under the Residential Properties (First-hand Sales) Ordinance.

### 備註：

因技術性問題，此鳥瞰照片所顯示的範圍超過《一手住宅物業銷售條例》的規定。

# OUTLINE ZONING PLAN ETC. RELATING TO THE DEVELOPMENT 關於發展項目的分區計劃大綱圖等

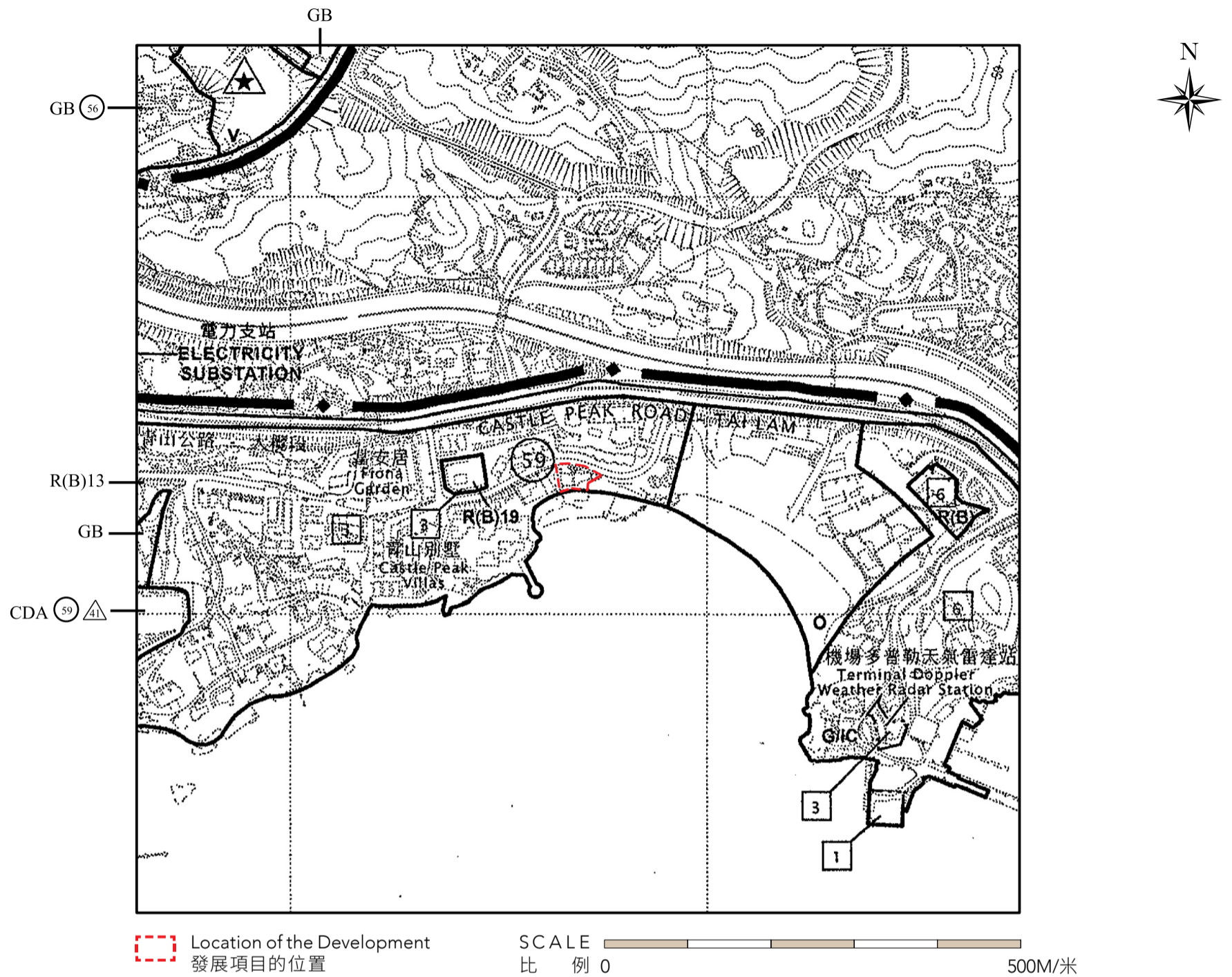

Adopted from the Approved Tuen Mun Outline Zoning Plan with Plan No. S/TM/41, gazetted on 13 June 2025, with adjustments where necessary.

摘錄自2025年6月13日刊憲之屯門分區計劃大綱核准圖，圖則編號為S/TM/41，經修正處理。

## NOTATION 圖例

### ZONES 地帶

- CDA Comprehensive Development Area  
綜合發展區
- R(B) Residential (Group B)  
住宅(乙類)
- V Village Type Development  
鄉村式發展
- G/I/C Government, Institution or Community  
政府、機構或社區
- O Open Space  
休憩用地
- GB Green Belt  
綠化地帶

### COMMUNICATIONS 交通

- Major Road and Junction  
主要道路及路口

### MISCELLANEOUS 其他

- Boundary of Planning Scheme  
規劃範圍界線
- Building Height Control Zone Boundary  
建築物高度管制區界線
- 1 Planning Area Number  
規劃區編號
- 100 Maximum Building Height  
(In Metres Above Principal Datum)  
最高建築物高度(在主水平基準上若干米)
- Maximum Building Height Restriction  
As Stipulated On The Notes  
《註釋》內訂明最高建築物高度限制
- 3 Maximum Building Height  
(In Number Of Storeys)  
最高建築物高度(樓層數目)

Note:  
Due to technical reasons, this outline zoning plan has shown more than the area required under the Residential Properties (First-hand Sales) Ordinance.

備註：  
因技術性問題，此分區計劃大綱圖所顯示的範圍超過《一手住宅物業銷售條例》的規定。

# OUTLINE ZONING PLAN ETC. RELATING TO THE DEVELOPMENT 關乎發展項目的分區計劃大綱圖等

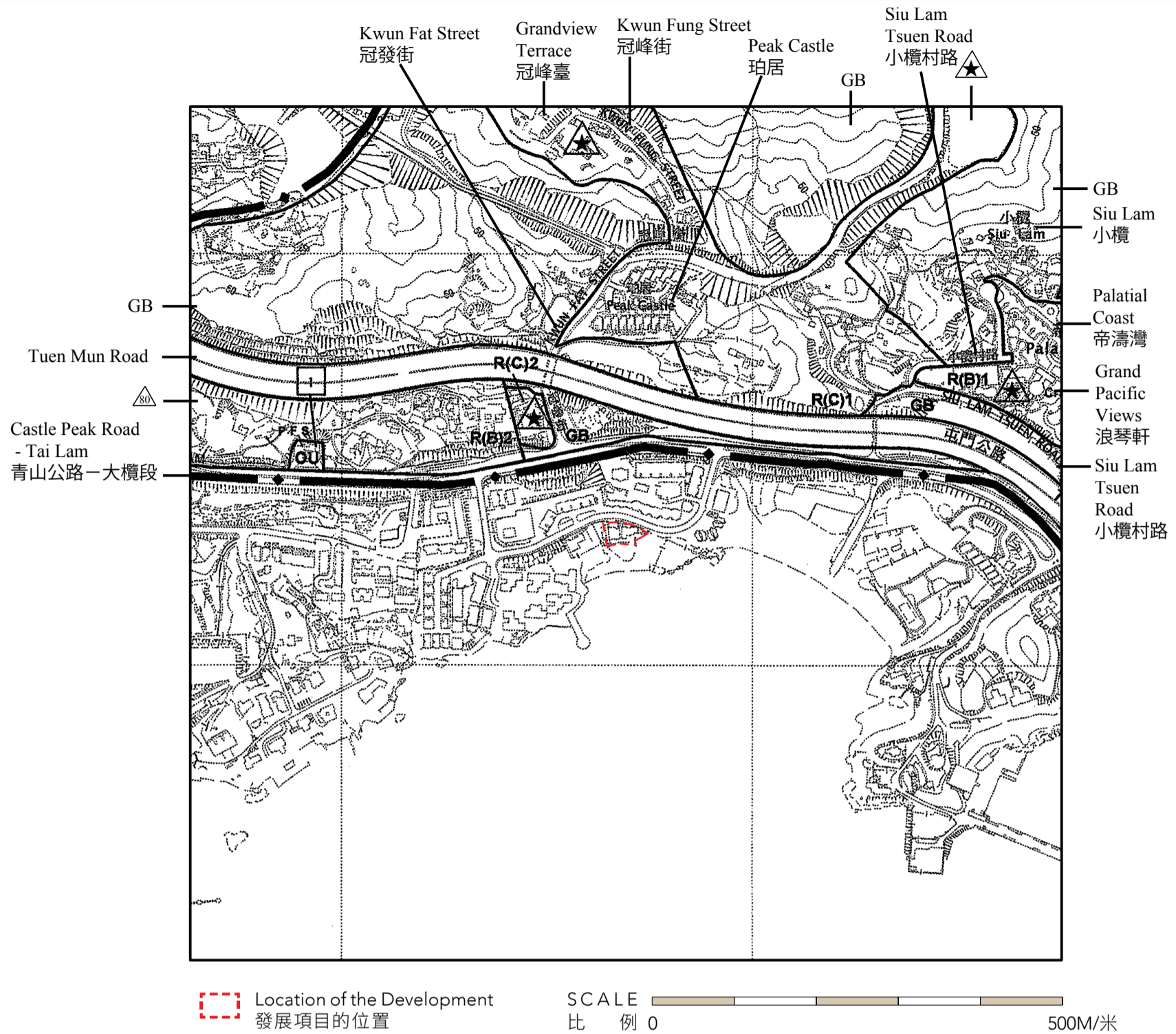

Adopted from the Approved So Kwun Wat Outline Zoning Plan with Plan No. S/TM-SKW/15, gazetted on 13 October 2023, with adjustments where necessary.

摘錄自2023年10月13日刊憲之掃管笏分區計劃大綱核准圖，圖則編號為S/TM-SKW/15，經修正處理。

## NOTATION 圖例

### ZONES 地帶

- R(B) Residential (Group B)  
住宅(乙類)
- R(C) Residential (Group C)  
住宅(丙類)
- OU Other Specified Uses  
其他指定用途
- GB Green Belt  
綠化地帶

### COMMUNICATIONS 交通

- Major Road and Junction  
主要道路及路口

### MISCELLANEOUS 其他

- Boundary of Planning Scheme  
規劃範圍界線
- Maximum Building Height  
(In Metres Above Principal Datum)  
最高建築物高度(在主水平基準上若干米)
- Maximum Building Height Restriction  
As Stipulated On The Notes  
《註釋》內訂明最高建築物高度限制
- Maximum Building Height  
(In Number Of Storeys)  
最高建築物高度(樓層數目)
- Petrol Filling Station  
加油站

Note:  
 Due to technical reasons, this outline zoning plan has shown more than the area required under the Residential Properties (First-hand Sales) Ordinance.

備註：  
 因技術性問題，此分區計劃大綱圖所顯示的範圍超過《一手住宅物業銷售條例》的規定。

# LAYOUT PLAN OF THE DEVELOPMENT

## 發展項目的布局圖

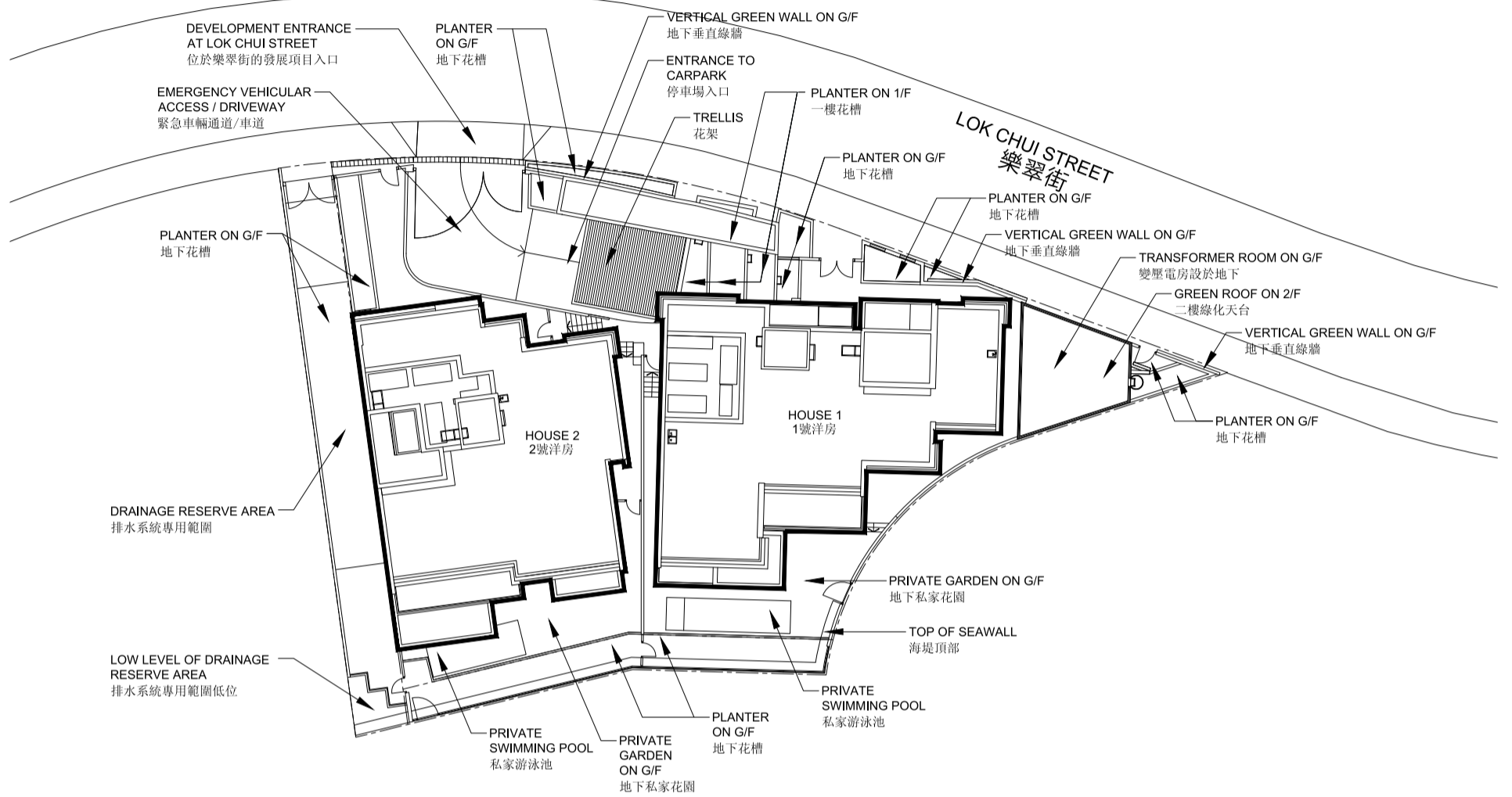

----- Boundary Line of the Development  
發展項目的界線

SCALE 0 1 2 3 4 5M/米  
比 例

# FLOOR PLANS OF RESIDENTIAL PROPERTIES IN THE DEVELOPMENT

## 發展項目的住宅物業的樓面平面圖

### Legend for floor plans 樓面平面圖圖例

A.C.	Air-conditioner	空調機
AC OUTDOOR PLANT	Air-conditioner Outdoor Plant	室外空調機
A.F.	Architectural Feature	建築裝飾
A.F. ABOVE	Architectural Feature Above	建築裝飾置上
BATH	Bathroom	浴室
BAL.	Balcony	露台
BAL. ABOVE	Balcony Above	露台置上
BR.	Bedroom	睡房
BUILDING LINE ABOVE	Building Line Above	建築物邊線置上
C.L.	Cat Ladder	豎梯
CANOPY	Canopy	簷篷
CANOPY ABOVE	Canopy Above	簷篷置上
COMMON AREA	Common Area	公用地方
CORRIDOR	Corridor	走廊
DIN.	Dining Room	飯廳
DN	Down	向下
DOGHOUSE	Mechanical & Electrical Services Duct Connecting to the Floor Below	連接下層的機電設施管道
EL	Electrical Room	電錶房
ELV	Extra Low Voltage Room	低電壓房
FAM.	Family Room	家庭廳
F	Fire Extinguisher	滅火筒
FH	Fire Hydrant	消防柱
FILTRATION PLANT PIT BELOW	Filtration Plant Pit Below	濾水裝置井置下
FITNESS	Fitness Room	健身房
FLAT CHANNEL	Flat Channel	平渠
FLAT ROOF	Flat Roof	平台
FOYER	Foyer	玄關
F.S. PUMP ROOM	Fire Services Pump Room	消防泵房
F.S. WATER TANK	Fire Services Water Tank	消防水缸
GAME RM.	Game Room	遊戲房
GARDEN	Garden	花園
GM	Gas Meter Cabinet	煤氣錶箱
H1	House 1	1 號洋房
H2	House 2	2 號洋房
HR	Hose Reel	消防喉轆
KIT.	Kitchen	廚房
LAV.	Lavatory	洗手間
LIBRARY	Library	圖書房
LIFT	Lift	升降機
LIFT LOBBY	Lift Lobby	升降機大堂
LIV.	Living Room	客廳
M.BR.	Master Bedroom	主人睡房
M.L.	Metal Louvre	金屬百葉

# FLOOR PLANS OF RESIDENTIAL PROPERTIES IN THE DEVELOPMENT

## 發展項目的住宅物業的樓面平面圖

M.L. AT HIGH LEVEL	Metal Louvre at High Level	金屬百葉置高位
PARKING	Parking	停車位
P.D.	Pipe Duct	管道槽
PLANTER (COMMON)	Planter (Common)	花槽 (公用)
POTABLE WATER & FLUSHING WATER PUMP ROOM	Potable Water and Flushing Water Pump Room	食水及沖廁水泵房
ROOF	Roof	天台
UP	Up	向上
U.P.	Utility Platform	工作平台
U.P. ABOVE	Utility Platform Above	工作平台置上
STO	Store Room	儲物房
SWIMMING POOL	Swimming Pool	游泳池
SKYLIGHT	Skylight	天窗
S.V.O.	Smoke Vent Outlet	排煙口
TOP OF ARCHITECTURAL FEATURE	Top of Architectural Feature	建築裝飾頂部
TOP OF CURTAIN WALL	Top of Curtain Wall	玻璃幕牆頂部
TOP OF SEAWALL	Top of Seawall	海堤頂部
UTILITY	Utility Room	工作間
VOID ABOVE	Void Above	上層中空
VOID	Void	中空
WALK-IN CLOSET	Walk-in Closet	衣帽間
WATER HEATER	Water Heater	熱水爐
WMC (FS)	Fire Services Water Meter Cabinet	消防水錶箱

Note applicable to this section:

1. Floor-to-floor height: refer to the height between the top surface of the structural slab of a floor and the top surface of the structural slab of its immediate upper floor
2. The dimensions of the floor plans are all structural dimensions in millimeter.
3. Those icons of fittings and fitments shown on the floor plans of residential properties like bathtubs, wash basins, water closets, shower cubicles, sink units, cabinets (if any) etc. are prepared in accordance with the latest approved building plans. Their shapes, dimensions, scales may be differed from the fittings and fitments actually provided and they are for indication and reference only.
4. There are architectural features, metal grilles and/or exposed pipes on the external walls of some of the floors. For details, please refer to the latest approved building plans and/or approved drainage plans and/or other relevant plans.
5. There are false ceilings for the air-conditioning fittings and/or mechanical and electrical services at some residential properties.

本節適用之備註：

1. 層與層之間的高度：指該樓層之石屎地台面與上一層石屎地台面之高度距離
2. 平面圖所列之數字為以毫米標示之建築結構尺寸。
3. 各住宅物業的樓面平面圖內所展示之裝置及設備的圖標如浴缸、洗手盆、座廁、淋浴間、洗滌盆、櫃(如有)等乃根據最新經批准的建築圖則擬備，其形狀、尺寸、比例或與實際提供的裝置及設備存在差異，僅供示意及參考之用。
4. 部分樓層外牆範圍設有建築裝飾、金屬格柵及/或外露喉管，詳細資料請參考最新經批准的建築圖則及/或經批准的排水設施圖則及/或其他相關圖則。
5. 部份住宅物業有用以裝置空調裝備及/或其他機電設備的假天花。

# FLOOR PLANS OF RESIDENTIAL PROPERTIES IN THE DEVELOPMENT

## 發展項目的住宅物業的樓面平面圖

### HOUSE 1 1號洋房



BASEMENT FLOOR PLAN  
地庫平面圖

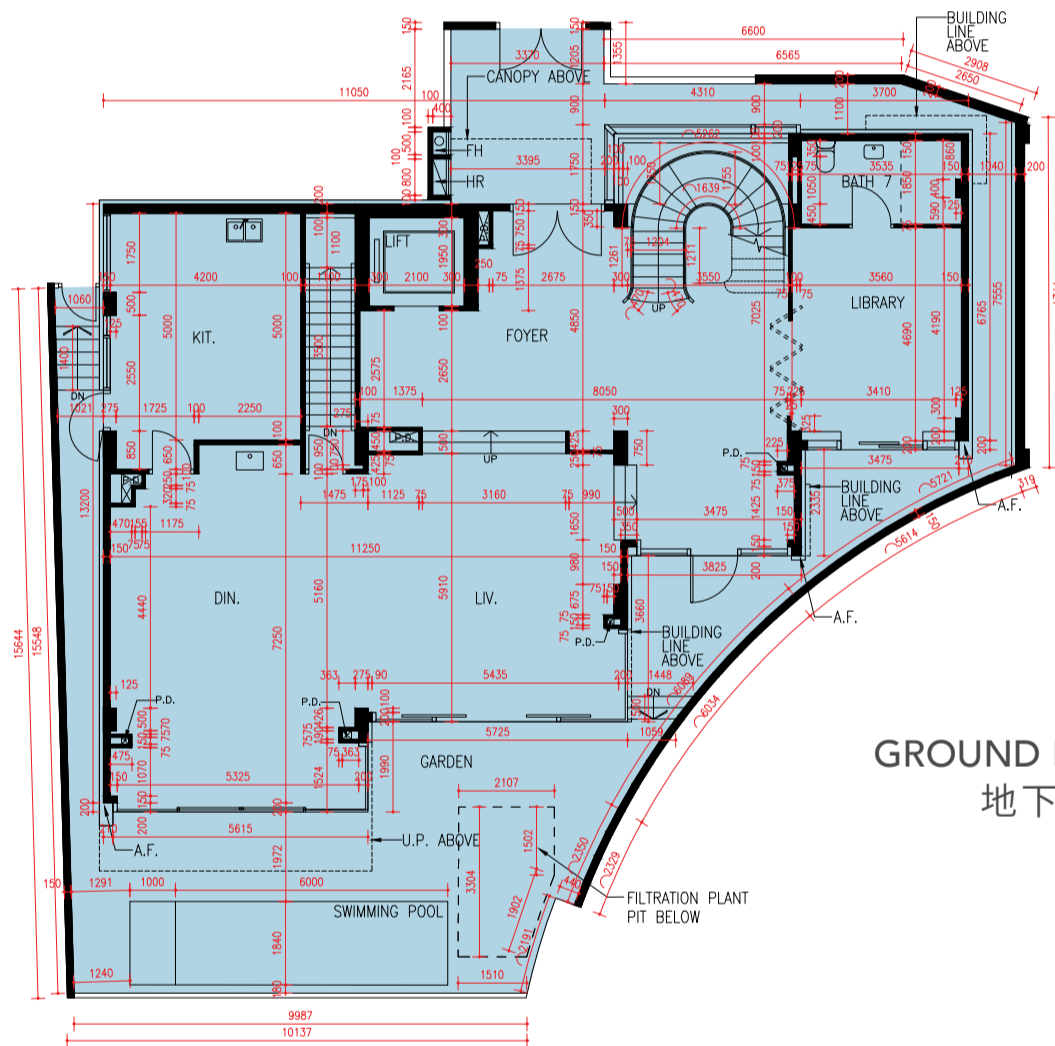
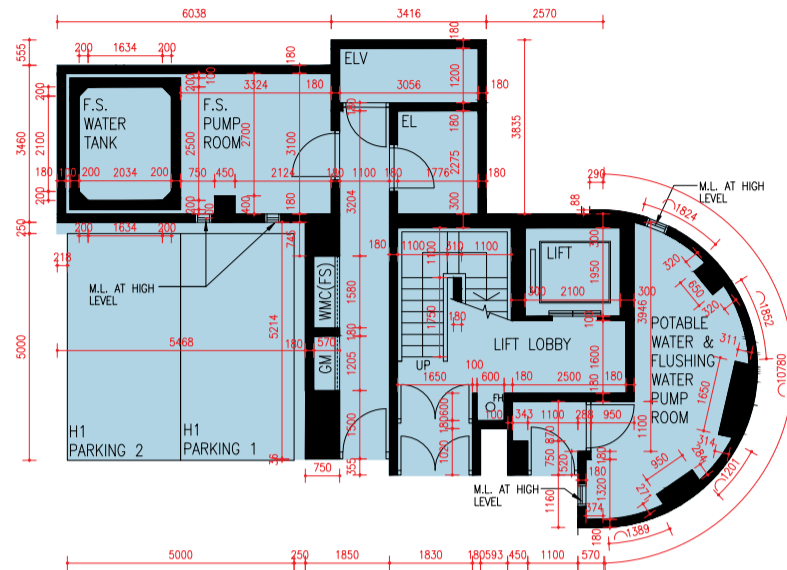

GROUND FLOOR PLAN  
地下平面圖

SCALE 0 1 2 3 4 5M/米  
比例 0 1 2 3 4 5M/米

The floor-to-floor height of the residential property: B/F: 2.166m - 3.744m, 3.170m, 4.285m, 4.78m; G/F: 3.420m, 3.665m, 3.915m; 1/F: 3.00m; 2/F: 3.20m; R/F: 2.50m.

The floor to floor height does not include the area under Balcony, Utility Platform and below staircase.

The thickness of the floor slab (excluding plaster) of the residential property: B/F: 200mm, 225mm; G/F: 150mm, 175mm, 225mm; 1/F: 150mm, 175mm, 200mm, 225mm; 2/F: 150mm, 200mm, 250mm; R/F: 175mm.

The internal areas of the residential properties on the upper floors will generally be slightly larger than those on the lower floors because of the reducing thickness of the structural walls on the upper floors. (Not applicable)

Notes:

- Please refer to page 19 and 20 of this sales brochure for legend of the terms and abbreviation shown on the floor plan above.
- Saleable Area of this House includes the areas of the Electrical Room, Fire Services Water Tank, Fire Services Pump Room, Potable Water and Flushing Water Pump Room, Extra Low Voltage Room, Gas Meter Cabinet, Fire Services Water Meter Cabinet and relevant lobbies or corridors (the total area is 940sq. ft. / 87.336sq. m.).

住宅物業的層與層之間的高度為：地庫：2.166米 - 3.744米、3.170米、4.285米、4.78米；地下：3.420米、3.665米、3.915米；一樓：3.00米；二樓：3.20米；天台：2.50米。

層與層之間的高度不包括露台、工作平台及樓梯下的位置。

住宅物業的樓板(不包括灰泥)的厚度為：地庫：200毫米、225毫米；地下：150毫米、175毫米、225毫米；一樓：150毫米、175毫米、200毫米、225毫米；二樓：150毫米、200毫米、250毫米；天台：175毫米。

因住宅物業的較高樓層的結構牆的厚度遞減，較高樓層的內部面積，一般比較低樓層的內部面積稍大(不適用)。

備註：

- 以上平面圖中顯示之名詞及簡稱請參閱本售樓說明書第19及20頁。
- 本洋房實用面積包括電錶房、消防水缸、消防泵房、食水及沖廁水泵房、低電壓房、煤氣錶箱、消防水錶箱及相關大堂或走廊面積(合共面積為940平方呎 / 87.336平方米)。

# FLOOR PLANS OF RESIDENTIAL PROPERTIES IN THE DEVELOPMENT

## 發展項目的住宅物業的樓面平面圖

### HOUSE 1

#### 1號洋房

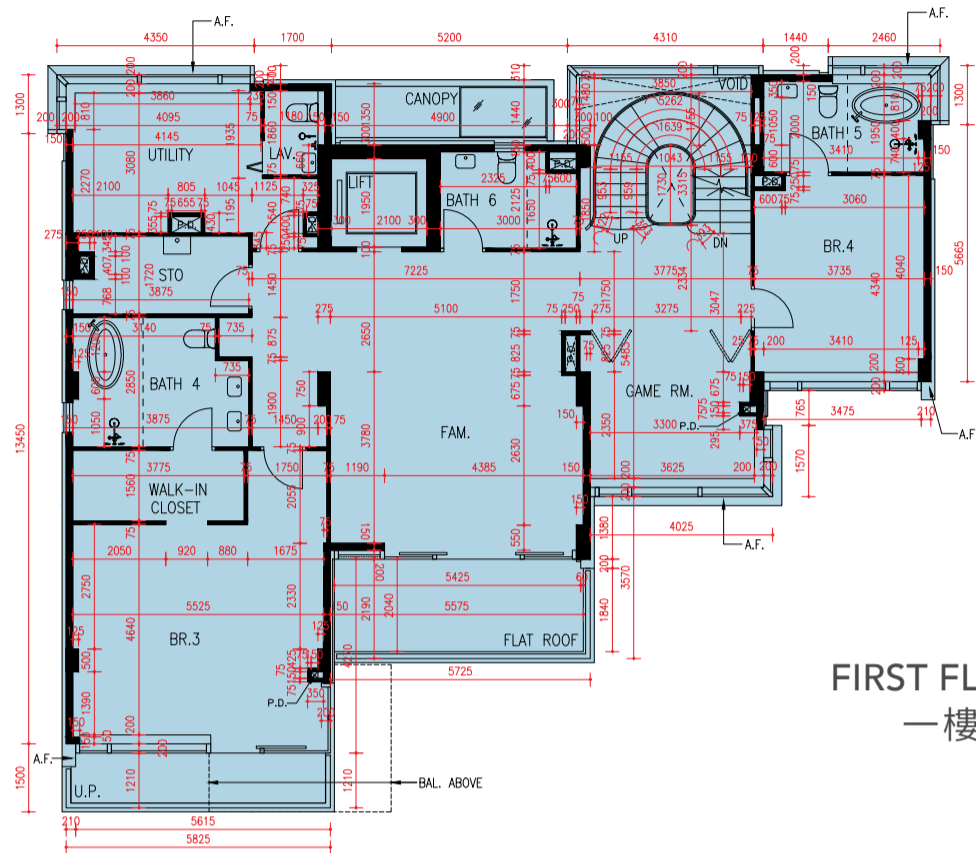

FIRST FLOOR PLAN  
一樓平面圖

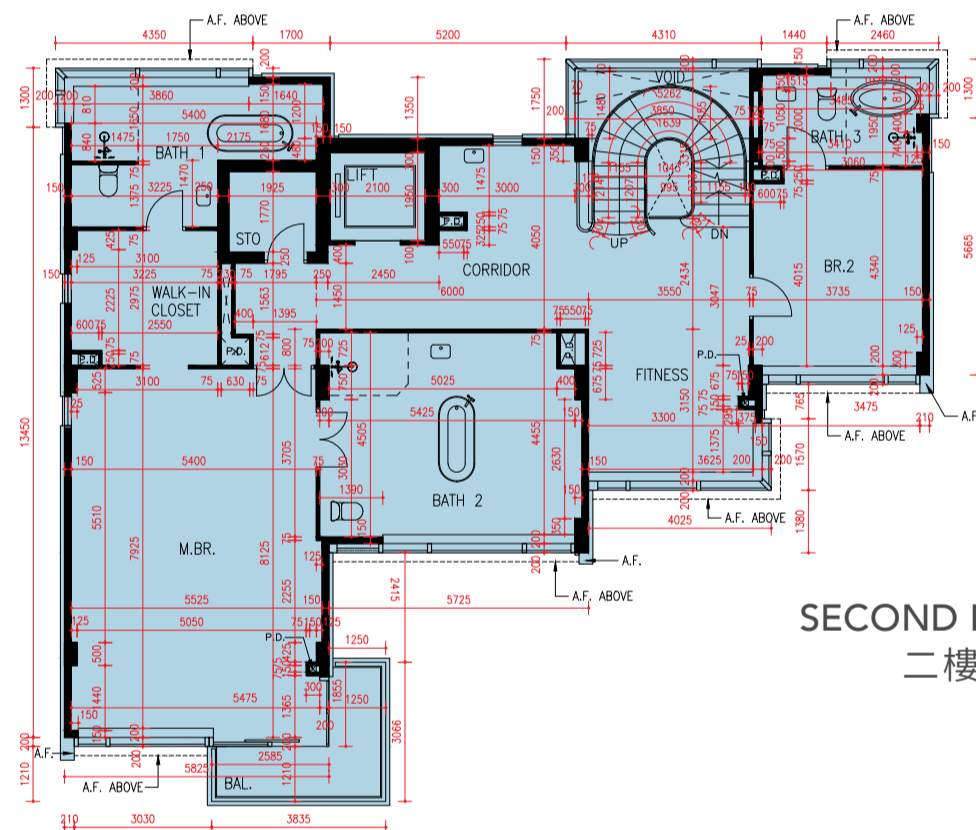

SECOND FLOOR PLAN  
二樓平面圖

SCALE 0 1 2 3 4 5M/米  
比例 0 1 2 3 4 5M/米

The floor-to-floor height of the residential property: B/F: 2.166m - 3.744m, 3.170m, 4.285m, 4.78m; G/F: 3.420m, 3.665m, 3.915m; 1/F: 3.00m; 2/F: 3.20m; R/F: 2.50m.

The floor to floor height does not include the area under Balcony, Utility Platform and below staircase.

The thickness of the floor slab (excluding plaster) of the residential property: B/F: 200mm, 225mm; G/F: 150mm, 175mm, 225mm; 1/F: 150mm, 175mm, 200mm, 225mm; 2/F: 150mm, 200mm, 250mm; R/F: 175mm.

The internal areas of the residential properties on the upper floors will generally be slightly larger than those on the lower floors because of the reducing thickness of the structural walls on the upper floors. (Not applicable)

#### Notes:

- Please refer to page 19 and 20 of this sales brochure for legend of the terms and abbreviation shown on the floor plan above.
- Saleable Area of this House includes the areas of the Electrical Room, Fire Services Water Tank, Fire Services Pump Room, Potable Water and Flushing Water Pump Room, Extra Low Voltage Room, Gas Meter Cabinet, Fire Services Water Meter Cabinet and relevant lobbies or corridors (the total area is 940sq. ft. / 87.336sq. m.).

住宅物業的層與層之間的高度為：地庫：2.166米 - 3.744米、3.170米、4.285米、4.78米；地下：3.420米、3.665米、3.915米；一樓：3.00米；二樓：3.20米；天台：2.50米。

層與層之間的高度不包括露台、工作平台及樓梯下的位置。

住宅物業的樓板(不包括灰泥)的厚度為：地庫：200毫米、225毫米；地下：150毫米、175毫米、225毫米；一樓：150毫米、175毫米、200毫米、225毫米；二樓：150毫米、200毫米、250毫米；天台：175毫米。

因住宅物業的較高樓層的結構牆的厚度遞減，較高樓層的內部面積，一般比較低樓層的內部面積稍大(不適用)。

#### 備註：

- 以上平面圖中顯示之名詞及簡稱請參閱本售樓說明書第19及20頁。
- 本洋房實用面積包括電錶房、消防水缸、消防泵房、食水及沖廁水泵房、低電壓房、煤氣錶箱、消防水錶箱及相關大堂或走廊面積(合共面積為940平方呎 / 87.336平方米)。

# FLOOR PLANS OF RESIDENTIAL PROPERTIES IN THE DEVELOPMENT

## 發展項目的住宅物業的樓面平面圖

### HOUSE 1 1號洋房



UPPER ROOF PLAN  
上層天台平面圖

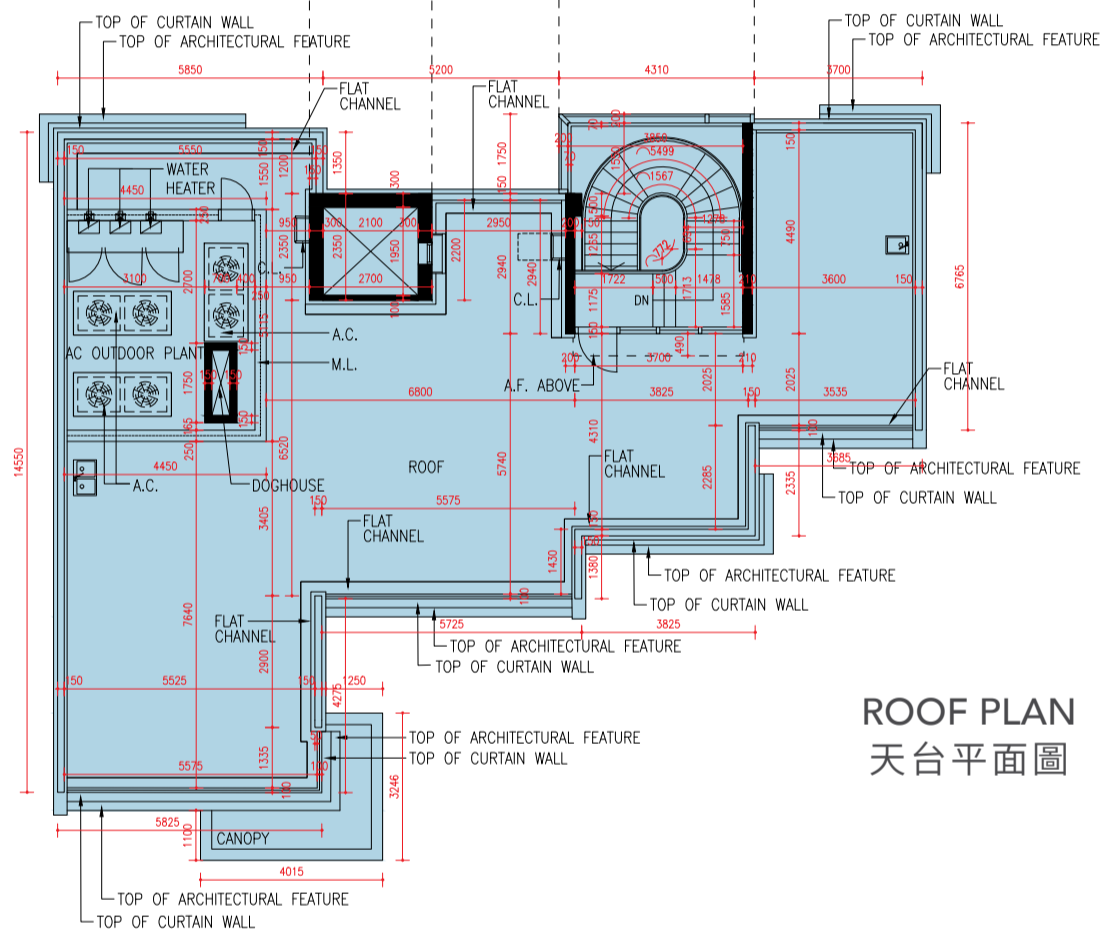
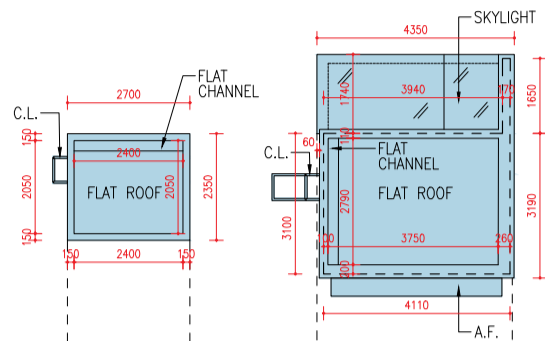

ROOF PLAN  
天台平面圖

SCALE 0 1 2 3 4 5M/米  
比例 0 1 2 3 4 5M/米

The floor-to-floor height of the residential property: B/F: 2.166m - 3.744m, 3.170m, 4.285m, 4.78m; G/F: 3.420m, 3.665m, 3.915m; 1/F: 3.00m; 2/F: 3.20m; R/F: 2.50m.

The floor to floor height does not include the area under Balcony, Utility Platform and below staircase.

The thickness of the floor slab (excluding plaster) of the residential property: B/F: 200mm, 225mm; G/F: 150mm, 175mm, 225mm; 1/F: 150mm, 175mm, 200mm, 225mm; 2/F: 150mm, 200mm, 250mm; R/F: 175mm.

The internal areas of the residential properties on the upper floors will generally be slightly larger than those on the lower floors because of the reducing thickness of the structural walls on the upper floors. (Not applicable)

Notes:

- Please refer to page 19 and 20 of this sales brochure for legend of the terms and abbreviation shown on the floor plan above.
- Saleable Area of this House includes the areas of the Electrical Room, Fire Services Water Tank, Fire Services Pump Room, Potable Water and Flushing Water Pump Room, Extra Low Voltage Room, Gas Meter Cabinet, Fire Services Water Meter Cabinet and relevant lobbies or corridors (the total area is 940sq. ft. / 87.336sq. m.).

住宅物業的層與層之間的高度為：地庫：2.166米 - 3.744米、3.170米、4.285米、4.78米；地下：3.420米、3.665米、3.915米；一樓：3.00米；二樓：3.20米；天台：2.50米。

層與層之間的高度不包括露台、工作平台及樓梯下的位置。

住宅物業的樓板(不包括灰泥)的厚度為：地庫：200毫米、225毫米；地下：150毫米、175毫米、225毫米；一樓：150毫米、175毫米、200毫米、225毫米；二樓：150毫米、200毫米、250毫米；天台：175毫米。

因住宅物業的較高樓層的結構牆的厚度遞減，較高樓層的內部面積，一般比較低樓層的內部面積稍大(不適用)。

備註：

- 以上平面圖中顯示之名詞及簡稱請參閱本售樓說明書第19及20頁。
- 本洋房實用面積包括電錶房、消防水缸、消防泵房、食水及沖廁水泵房、低電壓房、煤氣錶箱、消防水錶箱及相關大堂或走廊面積(合共面積為940平方呎 / 87.336平方米)。

# FLOOR PLANS OF RESIDENTIAL PROPERTIES IN THE DEVELOPMENT 發展項目的住宅物業的樓面平面圖

## HOUSE 1 1號洋房

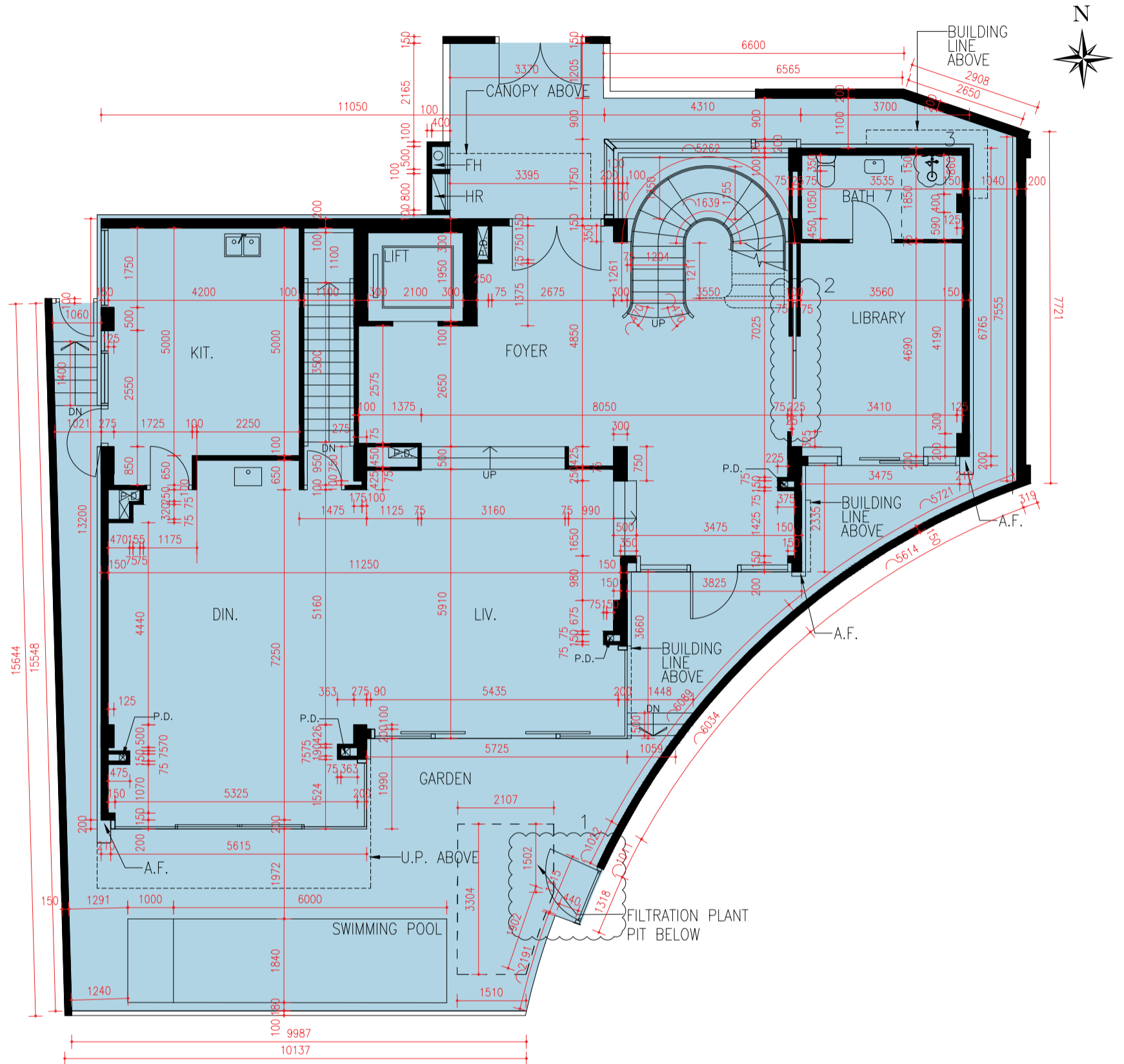

GROUND FLOOR PLAN  
(showing the "as-is" condition)

地下平面圖  
(顯示「現狀」)

SCALE 0 1 2 3 4 5M/米  
比 例

Those parts clouded on the above plan(s) have been altered by way of alteration and additional works, minor works or exempted building works under the Buildings Ordinance after completion of the development. The alteration works are as follows:

1. Part of the garden reinforced concrete fence wall has been changed to metal gate.
2. Library folding door has been changed to sliding door.
3. Sanitary fittings added in Bathroom 7 shower cubicle.

在上圖以雲狀標示的部分因在發展項目落成後進行改動及加建工程，小型工程或獲《建築物條例》豁免的工程而有所改動。該等改動如下：

1. 部份花園鋼筋水泥圍牆改為金屬閘門。
2. 圖書房原有摺門改為趟門。
3. 浴室7淋浴間增加衛浴潔具。

# FLOOR PLANS OF RESIDENTIAL PROPERTIES IN THE DEVELOPMENT

## 發展項目的住宅物業的樓面平面圖

### HOUSE 1

#### 1號洋房

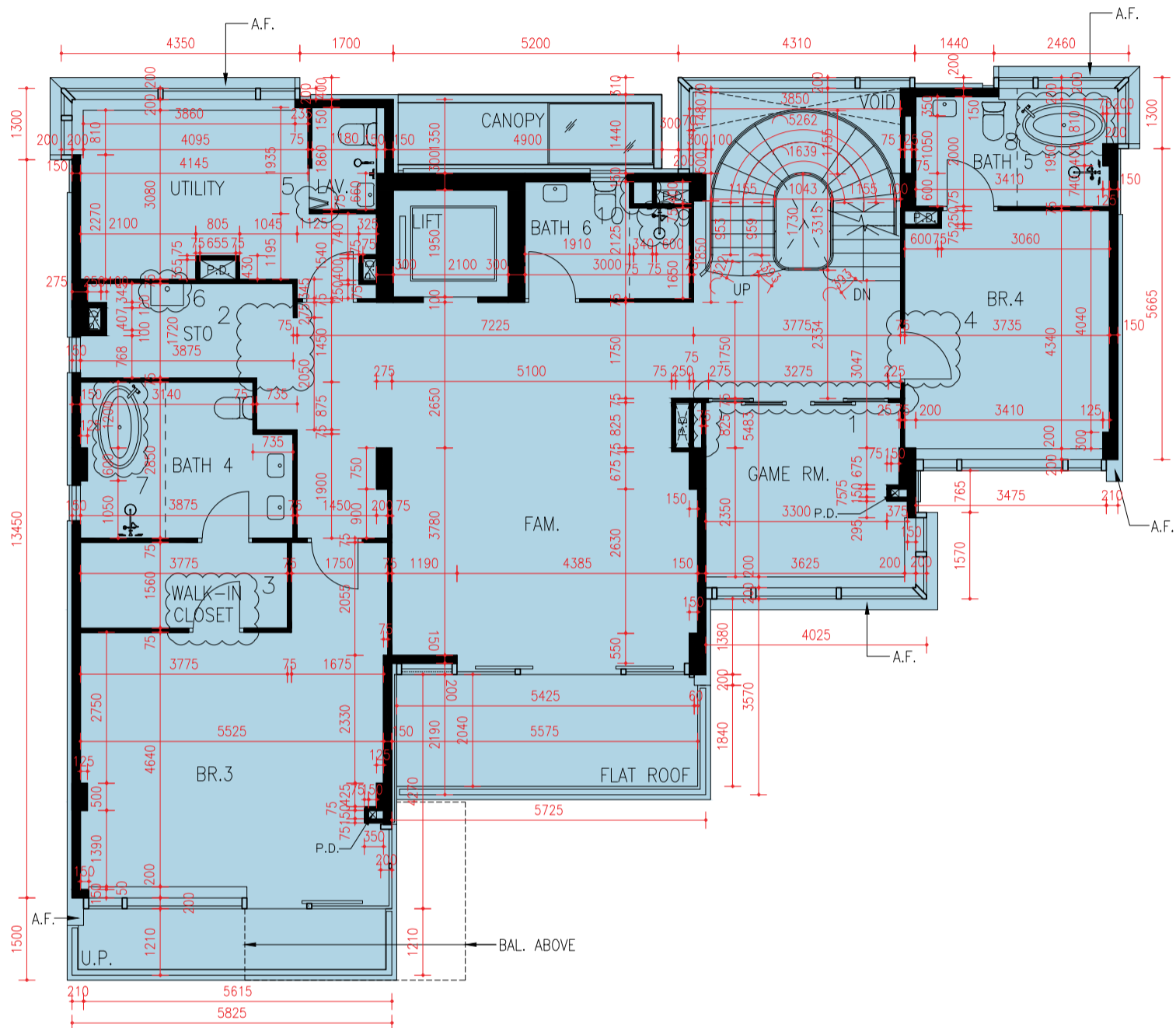

**FIRST FLOOR PLAN**  
(showing the "as-is" condition)  
一樓平面圖  
(顯示「現狀」)

SCALE 0 1 2 3 4 5M/米  
比 例

Those parts clouded on the above plan(s) have been altered by way of alteration and additional works, minor works or exempted building works under the Buildings Ordinance after completion of the development. The alteration works are as follows:

1. Game Room folding door has been changed to sliding door and partition wall had been added.
2. Store Room door and part of partition wall had been deleted.
3. Swing door added to Bedroom 3 walk-in closet.
4. Bedroom 4 door location has been changed.
5. Lavatory folding door open direction has been changed.
6. Position of sink in Store Room has been changed.
7. Position of sanitary fitting in Bathroom 4 has been changed.
8. Position of sanitary fitting in Bathroom 5 has been changed.
9. Position of sanitary fitting in Bathroom 6 shower cubicle has been changed.
10. Partition wall has been added in Bathroom 6 shower cubicle.

在上圖以雲狀標示的部分因在發展項目落成後進行改動及加建工程，小型工程或獲《建築物條例》豁免的工程而有所改動。該等改動如下：

1. 遊戲房原有摺門改為趟門及增加間隔牆。
2. 儲物房原有門及部份間隔牆取消。
3. 睡房3衣帽間增加掩門。
4. 睡房4門位置改動。
5. 洗手間摺門開啟方向更改。
6. 儲物房洗手盤位置改動。
7. 浴室4衛浴潔具位置改動。
8. 浴室5衛浴潔具位置改動。
9. 浴室6淋浴間衛浴潔具位置改動。
10. 浴室6淋浴間增加間隔牆。

# FLOOR PLANS OF RESIDENTIAL PROPERTIES IN THE DEVELOPMENT 發展項目的住宅物業的樓面平面圖

## HOUSE 1 1號洋房

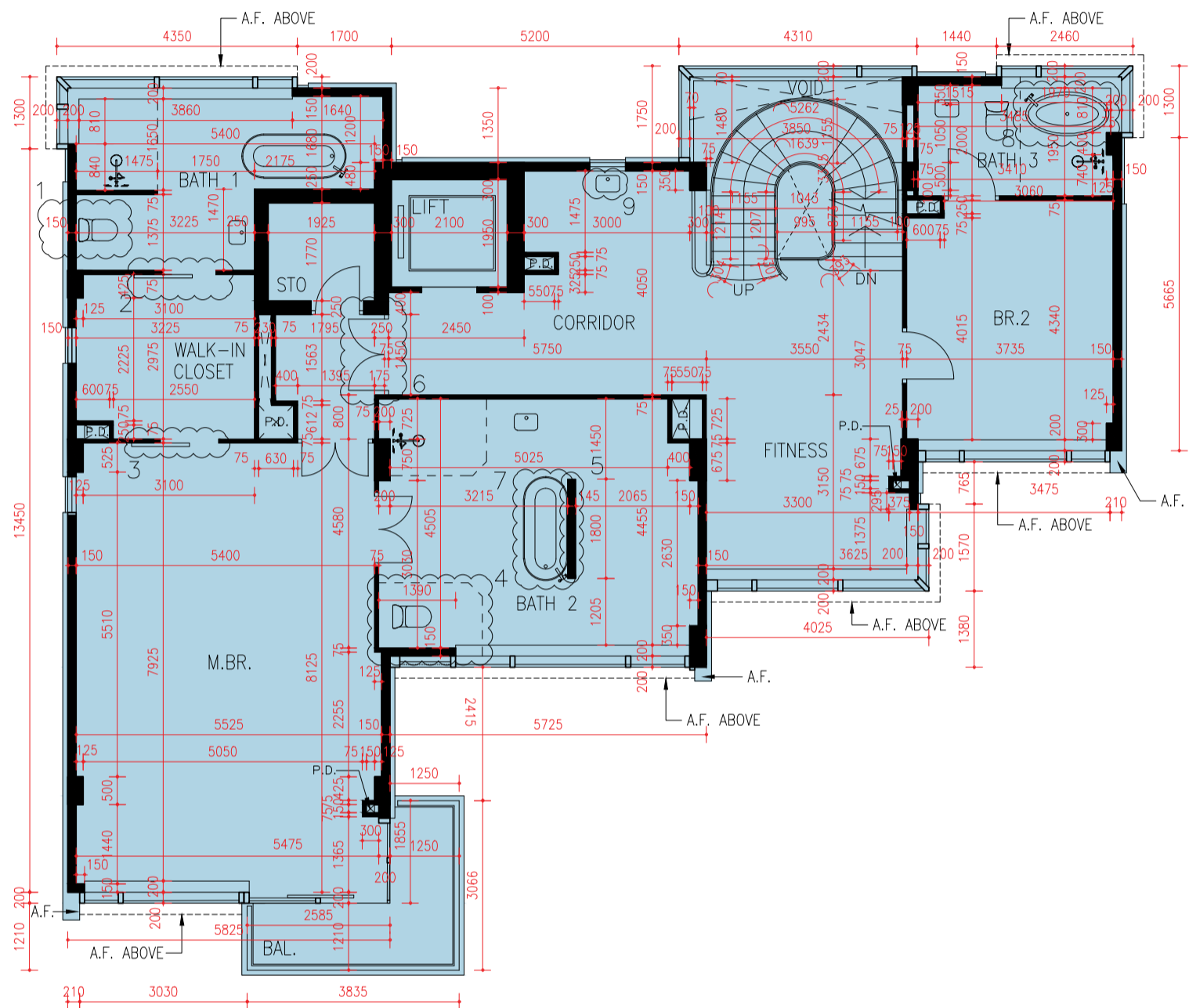

### SECOND FLOOR PLAN

(showing the "as-is" condition)

### 二樓平面圖

(顯示「現狀」)

SCALE 0 1 2 3 4 5M/米  
比 例

Those parts clouded on the above plan(s) have been altered by way of alteration and additional works, minor works or exempted building works under the Buildings Ordinance after completion of the development. The alteration works are as follows:

1. Position of sanitary fittings and drainage works in Bathroom 1 has been changed.
2. Bathroom 1 swing door has been changed to sliding door.
3. Sliding door has been added to Master Bedroom walk-in closet.
4. Glass cubicle has been added at Bathroom 2.
5. Partition wall has been added at Bathroom 2.
6. Swing door has been added at Corridor.
7. Position of sanitary fitting in Bathroom 2 has been changed.
8. Position of sanitary fitting in Bathroom 3 has been changed.
9. Position of sink in Corridor has been changed.

在上圖以雲狀標示的部分因在發展項目落成後進行改動及加建工程，小型工程或獲《建築物條例》豁免的工程而有所改動。該等改動如下：

1. 浴室1衛浴潔具及排水渠位置改動。
2. 浴室1原有掩門改為趟門。
3. 主人睡房衣帽間增加趟門。
4. 浴室2增加玻璃間隔。
5. 浴室2增加間隔牆。
6. 走廊增加掩門。
7. 浴室2衛浴潔具位置改動。
8. 浴室3衛浴潔具位置改動。
9. 走廊洗手盤位置改動。

# FLOOR PLANS OF RESIDENTIAL PROPERTIES IN THE DEVELOPMENT

## 發展項目的住宅物業的樓面平面圖

### HOUSE 2

#### 2號洋房

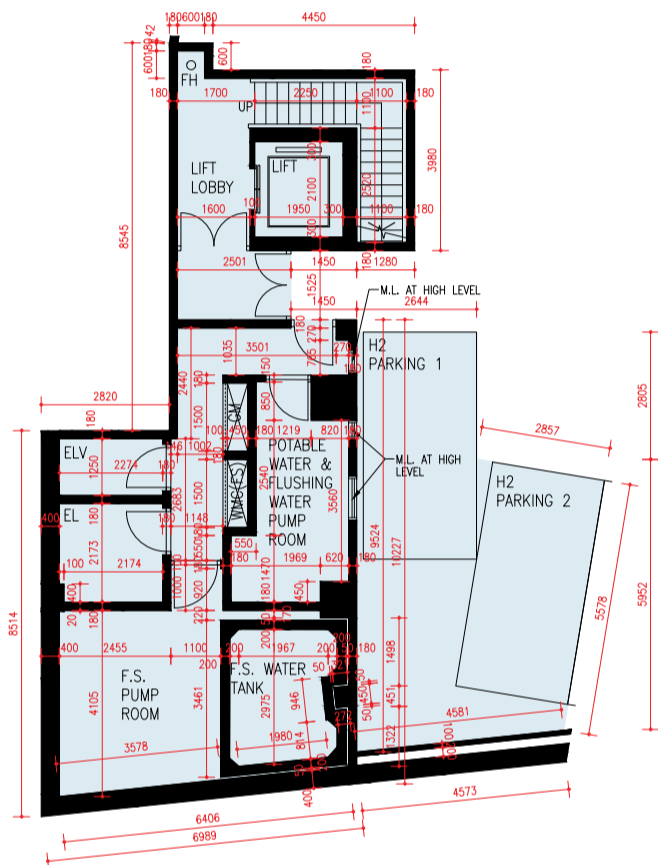

**BASEMENT FLOOR PLAN**  
地庫平面圖

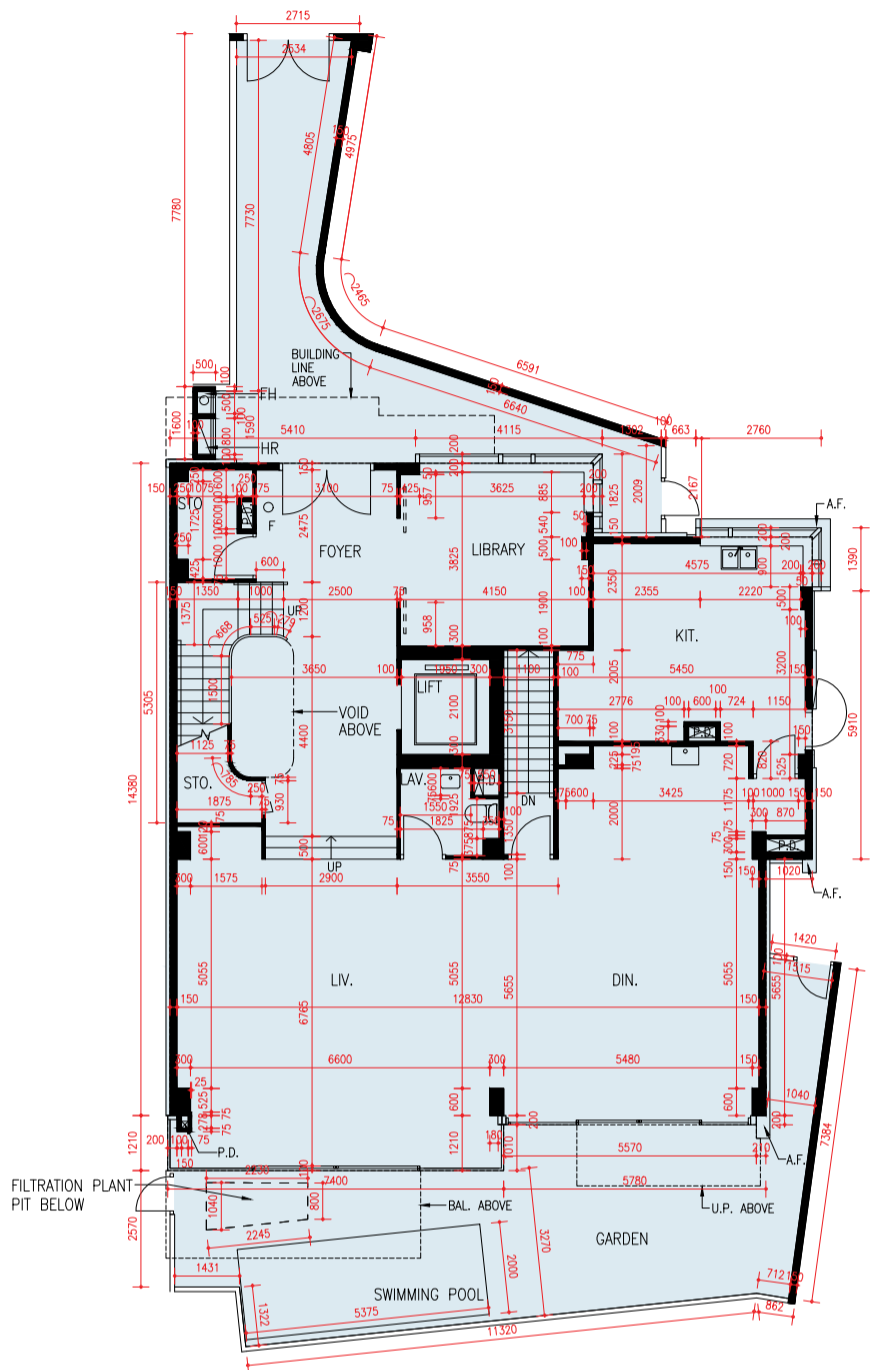

**GROUND FLOOR PLAN**  
地下平面圖

SCALE 0 1 2 3 4 5M/米  
比例

The floor-to-floor height of the residential property: B/F: 2.555m, 2.655m, 3.755m, 4.055m, 4.55m; G/F: 3.65m, 4.145m; 1/F: 2.75m, 3.00m; 2/F: 3.20m, 3.50m; R/F: 2.50m.

The floor to floor height does not include the area under Balcony, Utility Platform and below staircase.

The thickness of the floor slab (excluding plaster) of the residential property: B/F: 200mm; G/F: 150mm, 175mm, 225mm; 1/F: 150mm, 175mm, 200mm, 225mm; 2/F: 150mm, 200mm, 250mm; R/F: 150mm, 225mm.

The internal areas of the residential properties on the upper floors will generally be slightly larger than those on the lower floors because of the reducing thickness of the structural walls on the upper floors. (Not applicable)

**Notes:**

- Please refer to page 19 and 20 of this sales brochure for legend of the terms and abbreviation shown on the floor plan above.
- Saleable Area of this House includes the areas of the Electrical Room, Fire Services Water Tank, Fire Services Pump Room, Potable Water and Flushing Water Pump Room, Extra Low Voltage Room, Gas Meter Cabinet, Fire Services Water Meter Cabinet and relevant lobbies or corridors (the total area is 983sq. ft. / 91.368sq. m.).

住宅物業的層與層之間的高度為：地庫：2.555米、2.655米、3.755米、4.055米、4.55米；地下：3.65米、4.145米；一樓：2.75米、3.00米；二樓：3.20米、3.50米；天台：2.50米。

層與層之間的高度不包括露台、工作平台及樓梯下的位置。

住宅物業的樓板(不包括灰泥)的厚度為：地庫：200毫米；地下：150毫米、175毫米、225毫米；一樓：150毫米、175毫米、200毫米、225毫米；二樓：150毫米、200毫米、250毫米；天台：150毫米、225毫米。

因住宅物業的較高樓層的結構牆的厚度遞減，較高樓層的內部面積，一般比較低樓層的內部面積稍大(不適用)。

**備註：**

- 以上平面圖中顯示之名詞及簡稱請參閱本售樓說明書第19及20頁。
- 本洋房實用面積包括電錶房、消防水缸、消防泵房、食水及沖廁水泵房、低電壓房、煤氣錶箱、消防水錶箱及相關大堂或走廊面積(合共面積為983平方呎 / 91.368平方米)。

# FLOOR PLANS OF RESIDENTIAL PROPERTIES IN THE DEVELOPMENT

## 發展項目的住宅物業的樓面平面圖

### HOUSE 2

### 2號洋房

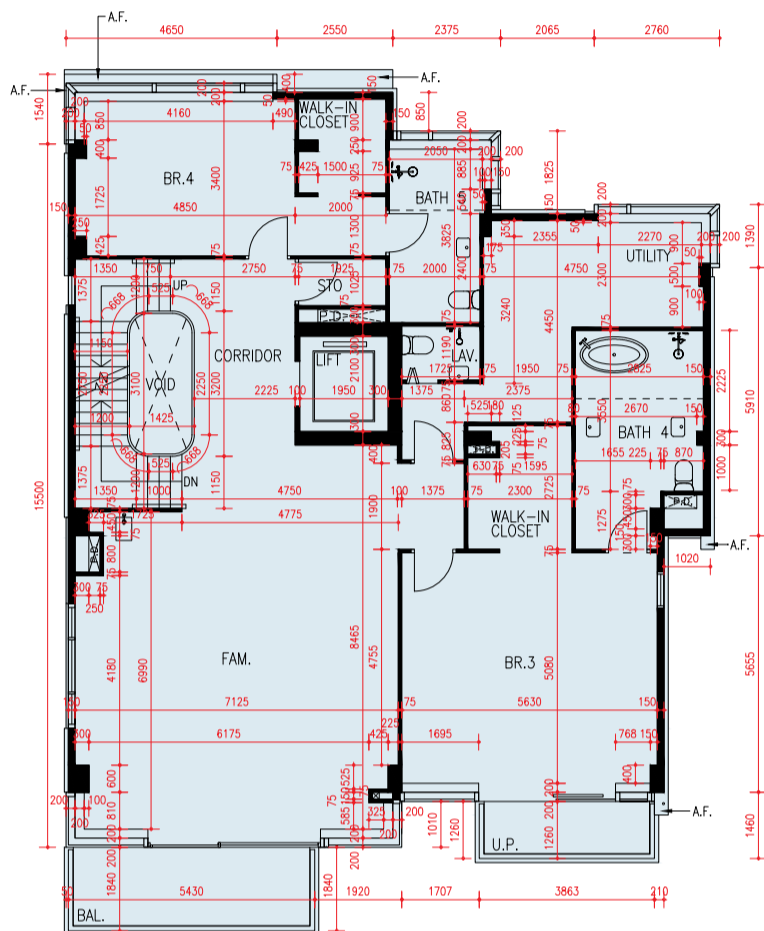

FIRST FLOOR PLAN  
一樓平面圖

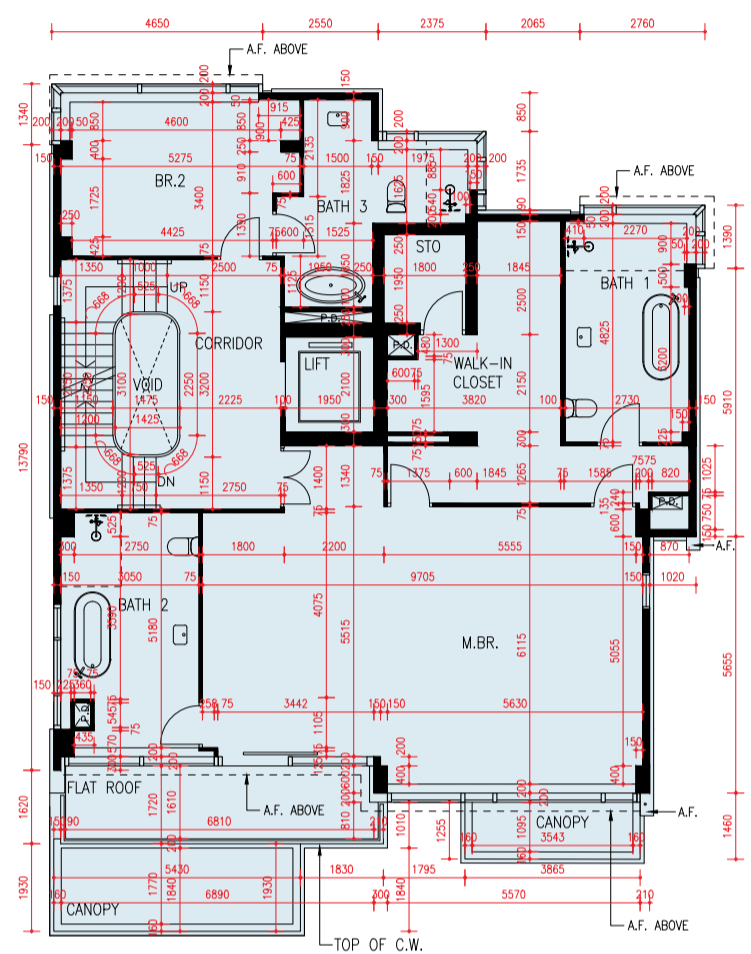

SECOND FLOOR PLAN  
二樓平面圖

SCALE 0 1 2 3 4 5M/米  
比例 0 1 2 3 4 5M/米

The floor-to-floor height of the residential property: B/F: 2.555m, 2.655m, 3.755m, 4.055m, 4.55m; G/F: 3.65m, 4.145m; 1/F: 2.75m, 3.00m; 2/F: 3.20m, 3.50m; R/F: 2.50m.

The floor to floor height does not include the area under Balcony, Utility Platform and below staircase.

The thickness of the floor slab (excluding plaster) of the residential property: B/F: 200mm; G/F: 150mm, 175mm, 225mm; 1/F: 150mm, 175mm, 200mm, 225mm; 2/F: 150mm, 200mm, 250mm; R/F: 150mm, 225mm.

The internal areas of the residential properties on the upper floors will generally be slightly larger than those on the lower floors because of the reducing thickness of the structural walls on the upper floors. (Not applicable)

Notes:

- Please refer to page 19 and 20 of this sales brochure for legend of the terms and abbreviation shown on the floor plan above.
- Saleable Area of this House includes the areas of the Electrical Room, Fire Services Water Tank, Fire Services Pump Room, Potable Water and Flushing Water Pump Room, Extra Low Voltage Room, Gas Meter Cabinet, Fire Services Water Meter Cabinet and relevant lobbies or corridors (the total area is 983sq. ft. / 91.368sq. m.).

住宅物業的層與層之間的高度為：地庫：2.555米、2.655米、3.755米、4.055米、4.55米；地下：3.65米、4.145米；一樓：2.75米、3.00米；二樓：3.20米、3.50米；天台：2.50米。

層與層之間的高度不包括露台、工作平台及樓梯下的位置。

住宅物業的樓板(不包括灰泥)的厚度為：地庫：200毫米；地下：150毫米、175毫米、225毫米；一樓：150毫米、175毫米、200毫米、225毫米；二樓：150毫米、200毫米、250毫米；天台：150毫米、225毫米。

因住宅物業的較高樓層的結構牆的厚度遞減，較高樓層的內部面積，一般比較低樓層的內部面積稍大(不適用)。

備註：

- 以上平面圖中顯示之名詞及簡稱請參閱本售樓說明書第19及20頁。
- 本洋房實用面積包括電錶房、消防水缸、消防泵房、食水及沖廁水泵房、低電壓房、煤氣錶箱、消防水錶箱及相關大堂或走廊面積(合共面積為983平方呎 / 91.368平方米)。

# FLOOR PLANS OF RESIDENTIAL PROPERTIES IN THE DEVELOPMENT

## 發展項目的住宅物業的樓面平面圖

### HOUSE 2

#### 2號洋房

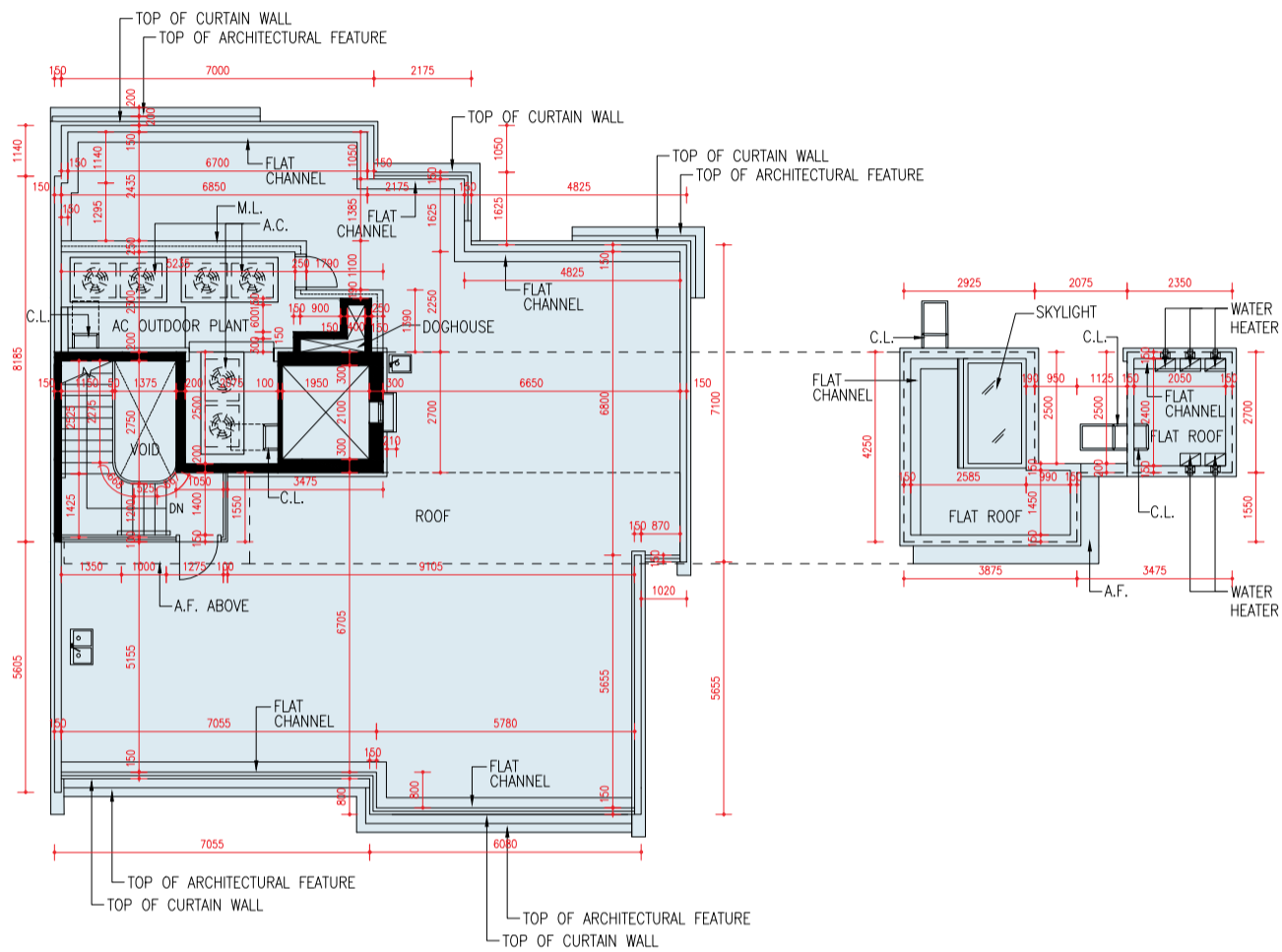

ROOF PLAN  
天台平面圖

UPPER ROOF PLAN  
上層天台平面圖

SCALE 0 1 2 3 4 5M/米  
比例

The floor-to-floor height of the residential property: B/F: 2.555m, 2.655m, 3.755m, 4.055m, 4.55m; G/F: 3.65m, 4.145m; 1/F: 2.75m, 3.00m; 2/F: 3.20m, 3.50m; R/F: 2.50m.

The floor to floor height does not include the area under Balcony, Utility Platform and below staircase.

The thickness of the floor slab (excluding plaster) of the residential property: B/F: 200mm; G/F: 150mm, 175mm, 225mm; 1/F: 150mm, 175mm, 200mm, 225mm; 2/F: 150mm, 200mm, 250mm; R/F: 150mm, 225mm.

The internal areas of the residential properties on the upper floors will generally be slightly larger than those on the lower floors because of the reducing thickness of the structural walls on the upper floors. (Not applicable)

Notes:

- Please refer to page 19 and 20 of this sales brochure for legend of the terms and abbreviation shown on the floor plan above.
- Saleable Area of this House includes the areas of the Electrical Room, Fire Services Water Tank, Fire Services Pump Room, Potable Water and Flushing Water Pump Room, Extra Low Voltage Room, Gas Meter Cabinet, Fire Services Water Meter Cabinet and relevant lobbies or corridors (the total area is 983sq. ft. / 91.368sq. m.).

住宅物業的層與層之間的高度為：地庫：2.555米、2.655米、3.755米、4.055米、4.55米；地下：3.65米、4.145米；一樓：2.75米、3.00米；二樓：3.20米、3.50米；天台：2.50米。

層與層之間的高度不包括露台、工作平台及樓梯下的位置。

住宅物業的樓板(不包括灰泥)的厚度為：地庫：200毫米；地下：150毫米、175毫米、225毫米；一樓：150毫米、175毫米、200毫米、225毫米；二樓：150毫米、200毫米、250毫米；天台：150毫米、225毫米。

因住宅物業的較高樓層的結構牆的厚度遞減，較高樓層的內部面積，一般比較低樓層的內部面積稍大(不適用)。

備註：

- 以上平面圖中顯示之名詞及簡稱請參閱本售樓說明書第19及20頁。
- 本洋房實用面積包括電錶房、消防水缸、消防泵房、食水及沖廁水泵房、低電壓房、煤氣錶箱、消防水錶箱及相關大堂或走廊面積(合共面積為983平方呎 / 91.368平方米)。

# FLOOR PLANS OF RESIDENTIAL PROPERTIES IN THE DEVELOPMENT

## 發展項目的住宅物業的樓面平面圖

### HOUSE 2 2號洋房

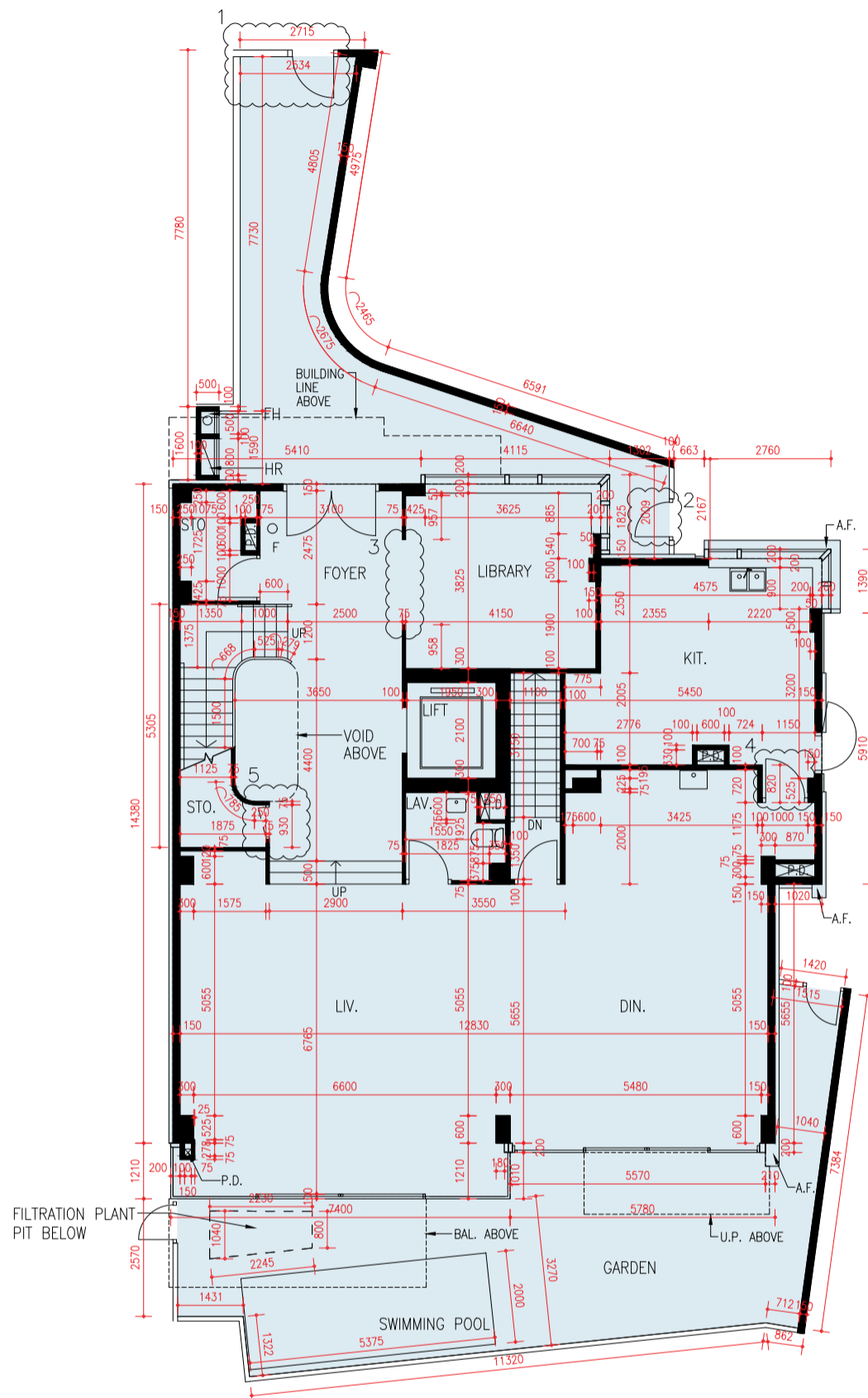

**GROUND FLOOR PLAN**  
(showing the "as-is" condition)

地下平面圖  
(顯示「現狀」)

SCALE 0 1 2 3 4 5M/米  
比 例

Those parts clouded on the above plan(s) have been altered by way of alteration and additional works, minor works or exempted building works under the Buildings Ordinance after completion of the development. The alteration works are as follows:

1. Part of the garden reinforced concrete fence wall has been changed to metal fence and double leaf metal gate has been changed to single leaf metal gate.
2. Garden metal gate swing direction has been changed.
3. Library sliding door has been deleted.
4. Kitchen door swing direction has been changed.
5. Store Room door swing direction changed.

在上圖以雲狀標示的部分因在發展項目落成後進行改動及加建工程，小型工程或獲《建築物條例》豁免的工程而有所改動。該等改動如下：

1. 部份花園鋼筋水泥圍牆改為金屬圍欄及原有雙扇金屬閘門改為單扇金屬閘門。
2. 花園金屬閘門開啟方向更改。
3. 圖書房原有趟門取消。
4. 廚房掩門開啟方向更改。
5. 儲物房掩門開啟方向更改。

# FLOOR PLANS OF RESIDENTIAL PROPERTIES IN THE DEVELOPMENT

## 發展項目的住宅物業的樓面平面圖

### HOUSE 2

#### 2號洋房

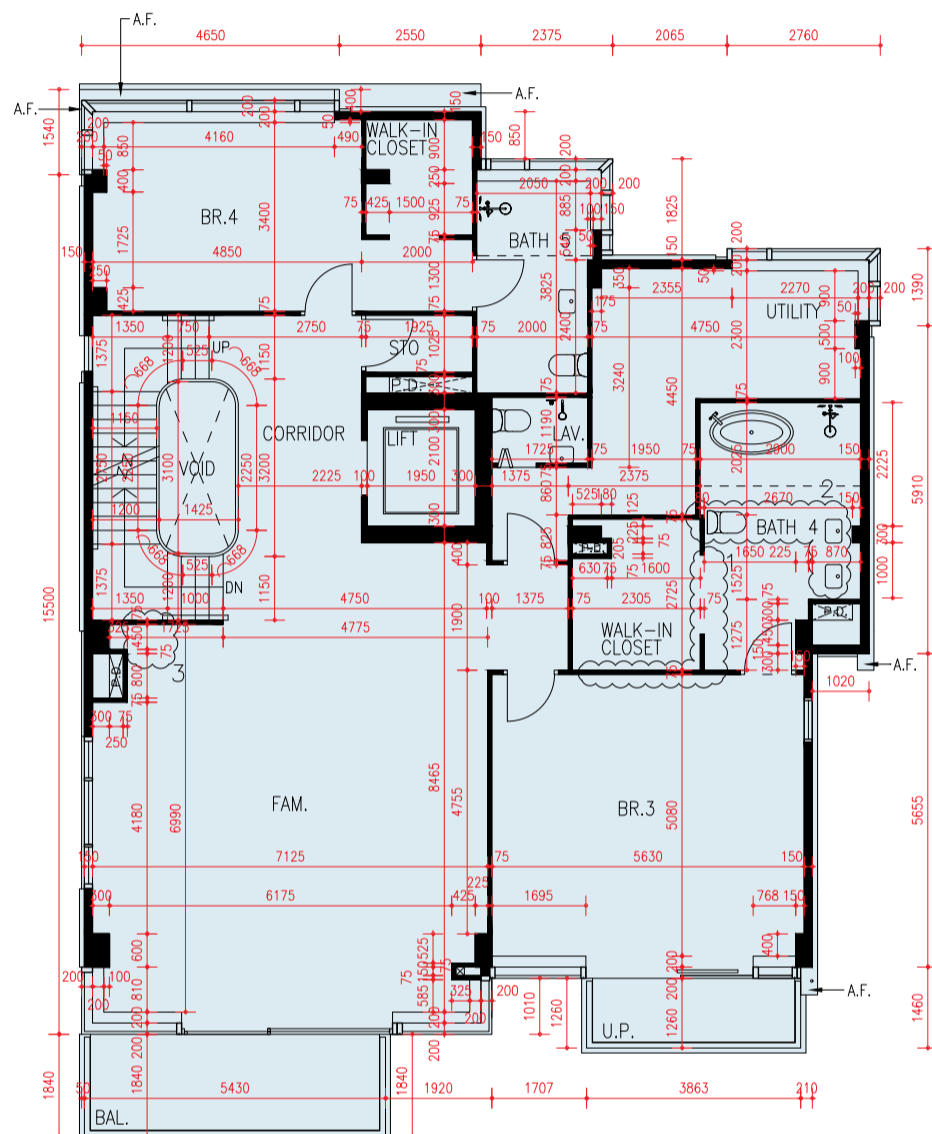

FIRST FLOOR PLAN  
(showing the "as-is" condition)

一樓平面圖  
(顯示「現狀」)

SCALE 0 1 2 3 4 5M/米  
比 例

Those parts clouded on the above plan(s) have been altered by way of alteration and additional works, minor works or exempted building works under the Buildings Ordinance after completion of the development. The alteration works are as follows:

1. Bedroom 3 walk-in closet entry location changed.
2. Position of sanitary fittings and drainage works in Bathroom 4 has been changed.
3. Sink in Family Room has been removed.

在上圖以雲狀標示的部分因在發展項目落成後進行改動及加建工程，小型工程或獲《建築物條例》豁免的工程而有所改動。該等改動如下：

1. 睡房3衣帽間入口位置修改。
2. 浴室4衛浴潔具及排水渠位置改動。
3. 家庭廳洗手盤移除。

# FLOOR PLANS OF RESIDENTIAL PROPERTIES IN THE DEVELOPMENT

## 發展項目的住宅物業的樓面平面圖

### HOUSE 2

#### 2號洋房

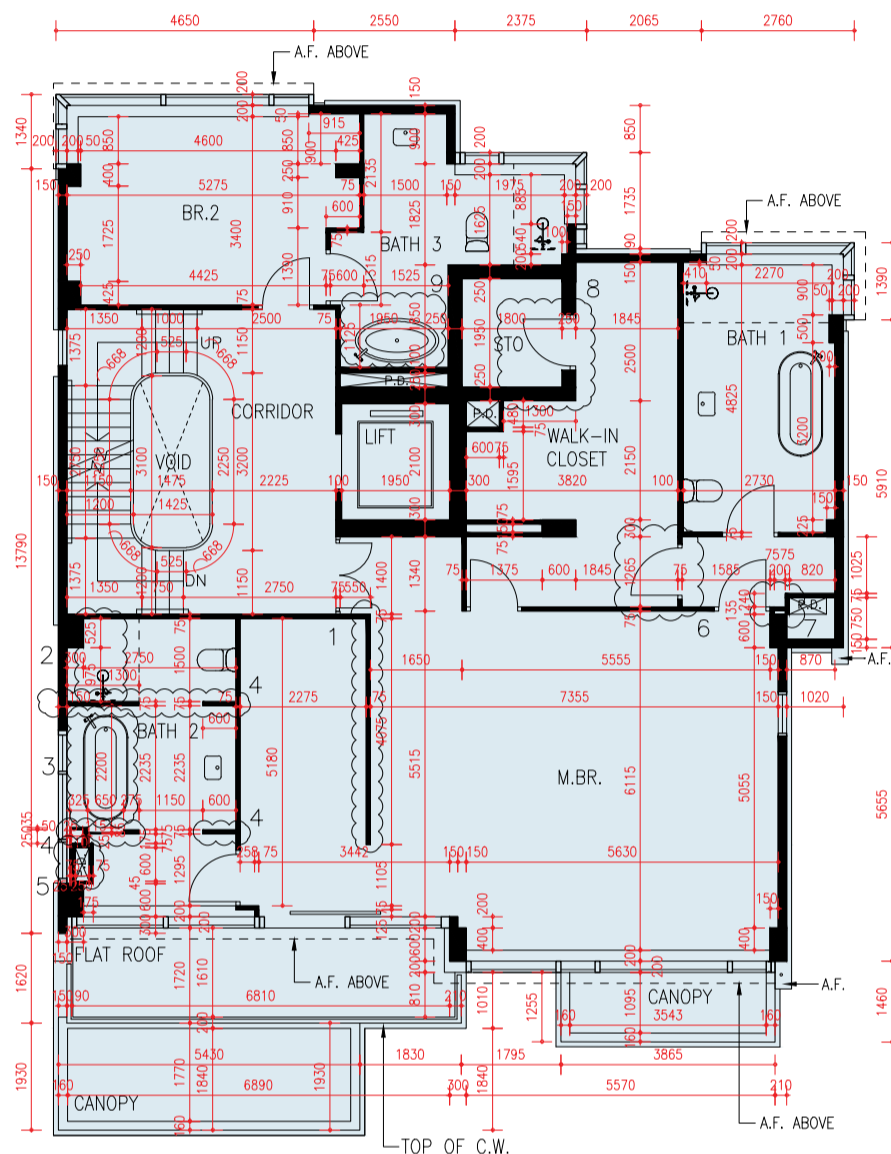

**SECOND FLOOR PLAN**  
(showing the "as-is" condition)

**二樓平面圖**  
(顯示「現狀」)

SCALE 5M/米  
比 例 0 1 2 3 4 5M/米

Those parts clouded on the above plan(s) have been altered by way of alteration and additional works, minor works or exempted building works under the Buildings Ordinance after completion of the development. The alteration works are as follows:

1. Partition wall has been added in Master Bedroom.
2. Position of sanitary fitting and drainage work in Bathroom 2 shower has been changed.
3. Position of sanitary fitting in Bathroom 2 has been changed.
4. Partition wall has been added in Bathroom 2.
5. Wall layout of pipe duct in Bathroom 2 has been changed.
6. Swing door has been added in Master Bedroom walk-in closet.
7. Partition wall has been added adjacent to Master Bedroom door.
8. Store Room swing door location has been changed.
9. Position of sanitary fittings in Bathroom 3 has been changed.

在上圖以雲狀標示的部分因在發展項目落成後進行改動及加建工程，小型工程或獲《建築物條例》豁免的工程而有所改動。該等改動如下：

1. 主人睡房增加間隔牆。
2. 浴室2淋浴間衛浴潔具及排水渠位置改動。
3. 浴室2衛浴潔具位置改動。
4. 浴室2增加間隔牆。
5. 浴室2管道槽間隔牆更改。
6. 主人睡房衣帽間增加掩門。
7. 主人睡房掩門旁增加間隔牆。
8. 儲物房掩門位置改動。
9. 浴室3衛浴潔具位置改動。



## AREA OF RESIDENTIAL PROPERTIES IN THE DEVELOPMENT 發展項目的住宅物業的面積

Description of Residential Property 物業的描述	Saleable Area (including balcony, utility platform and verandah, if any) sq. metre (sq.ft.) 實用面積 (包括露台, 工作平台及陽台(如有)) 平方米(平方呎)	Area of other specified items (Not included in the Saleable Area) 其他指明項目的面積(不計算入實用面積) sq. metre (sq.ft) 平方米(平方呎)									
		Air-conditioning Plant Room 空調機房	Bay Window 窗台	Cockloft 閣樓	Flat Roof 平台	Garden 花園	Parking Space 停車位	Roof 天台	Stairhood 梯屋	Terrace 前庭	Yard 庭院
1	713.676 (7682) 露台 Balcony: 6.961 (75) 工作平台 Utility Platform: 7.048 (76)	-	-	-	10.478 (113)	103.190 (1111)	27.586 (297)	153.063 (1648)	16.775 (181)	-	-
2	714.900 (7695) 露台 Balcony: 9.991 (108) 工作平台 Utility Platform: 4.868 (52)	-	-	-	10.184 (110)	83.754 (902)	37.955 (409)	155.288 (1672)	11.689 (126)	-	-

**Notes:**

- The areas in square metre have been converted to square feet based on a conversion rate of 1 square metre = 10.764 square feet and rounded off to the nearest integer. The areas in square feet may be slightly different from that shown in square metre.
- The saleable area and area of other specified items of the residential properties are calculated respectively in accordance with Section 8 and Part 2 of Schedule 2 of the Residential Properties (First-hand Sales) Ordinance.
- The area of the Parking Space specified in the section "Area of Residential Properties in the Development" in this sales brochure includes the area of the entire carport of the House. For the area inside the carport which is designated under the land grant for parking purpose, please refer to the area of parking space under the section "Floor Plans of Parking Spaces in the Development" in this sales brochure.

**備註:**

- 以平方呎列出的面積以1平方米=10.764平方呎換算,並以四捨五入至整數。平方呎與平方米之數字可能有些微差異。
- 實用面積及屬該住宅物業其他指明項目的面積是按照《一手住宅物業銷售條例》第8條及附表2第2部分別計算得出的。
- 本售樓說明書「發展項目中的住宅物業的面積」一節所列停車位之面積包括相關洋房之車房之全部面積。批地文件指明車房內用作停放車輛的地方之面積,請參閱本售樓說明書「發展項目中的停車位的樓面平面圖」一節之車位面積。

# FLOOR PLANS OF PARKING SPACES IN THE DEVELOPMENT 發展項目的停車位的樓面平面圖

## BASEMENT FLOOR PLAN 地庫平面圖

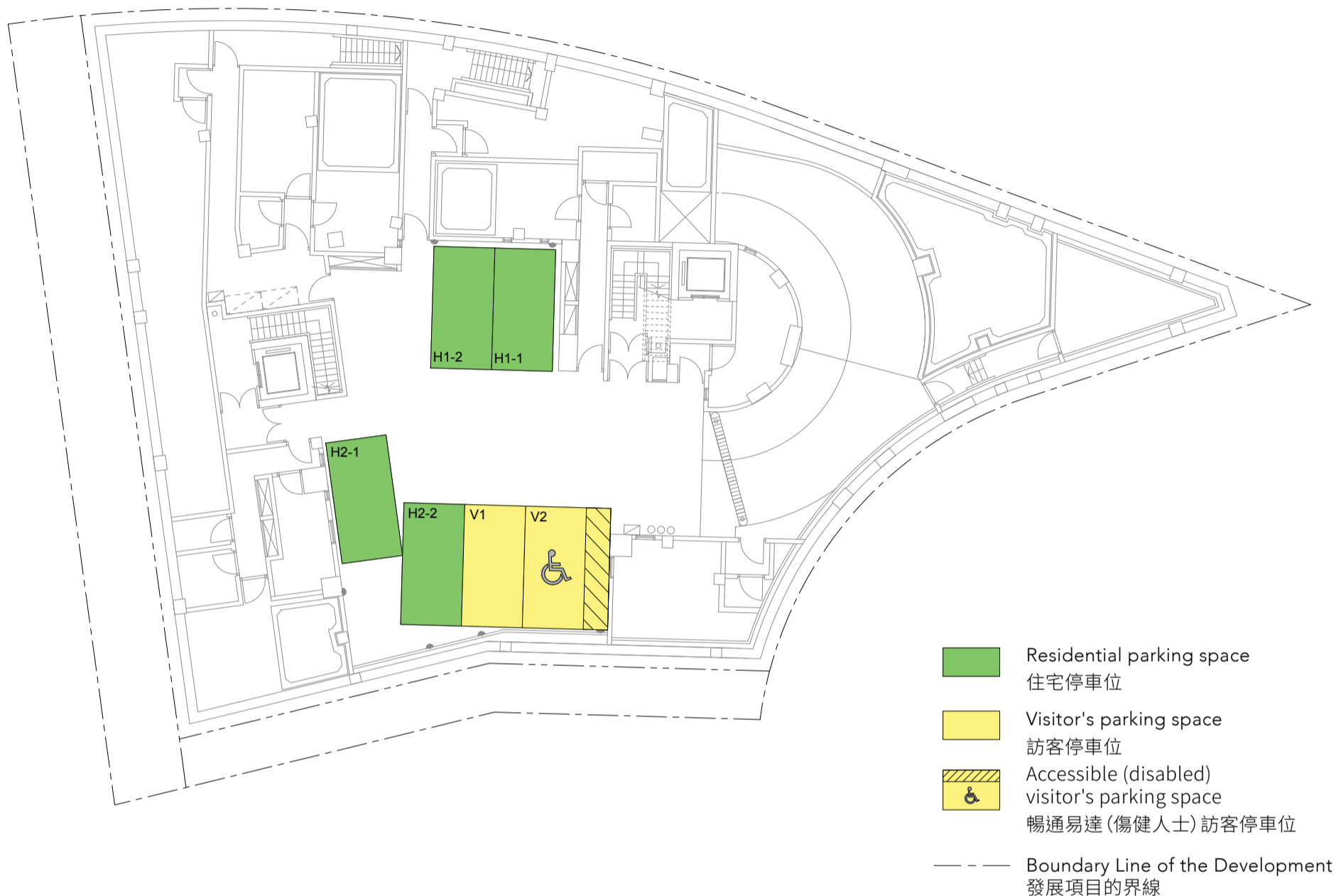

SCALE 5M/米  
比 例 0 1 2 3 4 5M/米

### Number, Dimensions and Areas of Parking Spaces (Basement) 停車位數目、尺寸、及面積(地庫)

Category of parking space 停車位類別	Number 數量	Parking Space Number 停車位編號	Dimension of Each Parking Space (Length x Width) (m.) 每個停車位尺寸 (長 x 闊) (米)	Area of Each Parking Space (sq.m.) 每個停車位面積 (平方米)
Residential parking space 住宅停車位	4	H1-1, H1-2, H2-1, H2-2	5 x 2.5	12.5
Visitor's parking space 訪客停車位	1	V1	5 x 2.5	12.5
Accessible (disabled) visitor's parking space 暢通易達(傷健人士)訪客停車位	1	V2	5 x 3.5	17.5

## SUMMARY OF PRELIMINARY AGREEMENT FOR SALE AND PURCHASE

### 臨時買賣合約的摘要

---

1. A preliminary deposit of 5% is payable on the signing of the preliminary agreement for sale and purchase.
  2. The preliminary deposit paid by the purchaser on the signing of that preliminary agreement will be held by a firm of solicitors acting for the owner, as stakeholders.
  3. If the purchaser fails to execute the agreement for sale and purchase within 5 working days after the date on which the purchaser enters into that preliminary agreement –
    - (i) that preliminary agreement is terminated;
    - (ii) the preliminary deposit is forfeited; and
    - (iii) the owner does not have any further claim against the purchaser for the failure.
1. 在簽署臨時買賣合約時須支付款額為5%的臨時訂金。
  2. 買方在簽署該臨時合約時支付的臨時訂金，會由代表擁有人行事的律師事務所以保證金保存人的身份持有。
  3. 如買方沒有於訂立該臨時合約的日期之後5個工作日內簽立買賣合約 –
    - (i) 該臨時合約即告終止；
    - (ii) 有關的臨時訂金即予沒收；及
    - (iii) 擁有人不得就買方沒有簽立買賣合約而針對買方提出進一步申索。

# SUMMARY OF DEED OF MUTUAL COVENANT

## 公契的摘要

### A. Common Parts of the Development

The Deed of Mutual Covenant and Management Agreement of the Development ("the DMC") provides the following for Common Areas and Common Facilities: -

"Estate Common Areas" means the whole of the Land and the Estate (except the Houses), designed or intended for common use and benefit of the Owner and shall include but not limited to such of the circulation passages, driveway, ramps, entrances and exits to the Estate, main switch room, sprinkler water tanks, sprinkler pump room, fire services water tank, fire services pump room, F.S. pump room (carpark), electrical room (carpark), Visitors' Carparking Spaces, water master meter room, TBE room, sewage treatment plant room, transformer room, vertical green walls, plantation areas, refuse collection room, external walls (except the internal plaster and internal finishes facing a House) and external finishes and features thereon, fence and fence walls of the whole Estate, green roof, Greenery Areas, areas for the installation or use of aerial broadcast distribution or telecommunications network facilities and other areas and spaces containing the Estate Common Facilities and other areas and spaces in any part or parts of the Estate which are for the common use and benefit of the Owners of the Estate and all other common parts specified in Schedule 1 to the Ordinance which are for the purpose of identification shown coloured Yellow on the plan(s) certified as to their accuracy by the Authorized Person annexed to the DMC.

"Estate Common Facilities" means all equipment, facilities and systems designated as being for the use, benefit or service of the Estate Common Areas and without limiting the generality of the foregoing, include: -

- (a) Such of the sewers, drains, water courses, pipes, gutters, wires and cables and other service facilities whether ducted or otherwise which are or at any time may be in, under or over or passing through the Estate through which water, sewage, gas, electricity and any other services are supplied to the Estate or any part or parts thereof;
- (b) Fire fighting installation and equipment installed at the Estate Common Areas;
- (c) Lamp posts, traffic lights and lighting within the Estate;
- (d) Lightning conductor of the Estate;
- (e) Trellis;
- (f) Existing Sewerage Treatment Facilities and the New Sewers;
- (g) Burglar alarm, metal gate and security systems (if any) which are for the use and benefit of the Land and the Estate as a whole and not for the use or benefit of a particular House; and
- (h) Other facilities and systems for the use and benefit of the Land and the Estate and not for the use and benefit of any particular Owner.

### B. Number of Undivided Shares Assigned to Each Residential Property in the Development

Please refer to the table entitled "Allocation of Undivided Shares of Residential Properties in the Development".

### C. Term of Years for which the Manager of the Development is Appointed

The Manager shall be appointed from the date of the DMC for an initial term of two (2) years. The appointment of the Manager may be terminated by the Manager or the Owners' Committee by giving not less than three (3) months' notice in writing in accordance with the terms of the DMC.

### D. Basis on which the Management Expenses are Shared among the Owners of the Residential Properties in the Development

The Management Expenses shall be apportioned between the Owners of the Estate in the following manner: -

- (a) Where any expenditure relates to the Estate Common Areas and/or the Estate Common Facilities, the expenditure shall form part of the Management Expenses of the Estate as a whole and shall be borne by all Owners of the Estate in accordance with the proportion that the respective Management Shares of the relevant part of the Estate bear to the total number of Management Shares of the Estate.

- (b) Notwithstanding anything contained in sub-clause (a), (i) where any expenditure relates solely to or is solely for the benefit of any House and no Owner other than the Owner entitled to the exclusive right and privilege to hold, use and occupy that House will receive any material benefit therefrom, then the full amount of such expenditure shall be borne by the Owner of such House and (ii) where any expenditure relates solely to or is solely for the benefit of a group of Owners but does not relate to or is not for the benefit of the other Owners, the full amount of such expenditure shall be apportioned between such Owners in proportion to their respective Management Shares.

### E. Basis on which the Management Fee Deposit is Fixed

The amount of Management Fee Deposit shall be equivalent to 3 months' Management Fee.

### F. Area (if any) in the Development Retained by the Owner for that Owner's Own Use

Not applicable.

### Allocation of Undivided Shares of Residential Properties in the Development

House 1	770/ 2,549
House 2	779/ 2,549

### Note:

- (1) Please refer to the DMC for full details. A full script of the DMC is available for inspection free of charge during office hours at the sales office upon request and copies will be provided on payment of photocopying charges.
- (2) Unless otherwise defined, capitalized terms used in the above shall have the same meaning of such terms of the DMC.

# SUMMARY OF DEED OF MUTUAL COVENANT

## 公契的摘要

### A. 發展項目的公用部分

發展項目公共契約及管理協議(「公契」)訂明下列有關公用地方及公用設施的條文：

「屋苑公用地方」指設計或擬供業主共用與共享的整個該土地及屋苑(洋房除外)，包括但不限於運轉通道、行車道、斜路、屋苑入口及出口、主電掣房、灑水器水箱、灑水器泵房、消防服務水箱、消防服務泵房、消防泵房(停車場)、電力房(停車場)、訪客停車位、總水錶房、電訊及廣播服務室、污水處理機房、電力變壓房、垂直綠化牆、花槽地方、垃圾收集房、外牆(面向洋房的內牆灰泥及內部裝修物料除外)及外部裝修物料及其上的設施、整個屋苑的圍欄及圍欄牆、綠化天台、綠化地方、安裝或使用天綫廣播分導或電訊網絡設施的地方及設有屋苑公用設施的其他地方與範圍及位於屋苑任何部分並供屋苑業主共用與共享的其他地方與範圍及所有條例附表一內所載的其他公用部分，該公用部分於公契夾附的圖則(該等圖則準確性經認可人士核實)上以黃色顯示。

「屋苑公用設施」指為屋苑公用地方的使用、利益或服務而設的所有設備、設施及系統。毋損前文之一般規定，屋苑公用設施包括：

- (a) 現時或於任何時間位於屋苑之內、之下或之上或跨越其中的該等下水道、排水道、水道、管道、溝渠、電線與電纜及其他服務設施(不論有否鋪設管道)，以將水、污水、氣體、電力及任何其他服務供應至屋苑或其任何部分；
- (b) 於屋苑公用地方安裝的滅火裝置與設備；
- (c) 屋苑內燈柱、交通燈及照明設施；
- (d) 屋苑的避雷裝置；
- (e) 花棚；
- (f) 現有污水處理設施和新的污水渠；
- (g) 為該土地及整個屋苑的使用及利益而設及並非為任何個別洋房的使用或利益而設的防盜鐘、金屬閘門及保安系統(如有)；及
- (h) 為該土地及屋苑的使用及利益而設及並非為任何個別業主的使用及利益而設的其他設施及系統。

### B. 分配予發展項目中的每個住宅物業的不分割份數的數目

請見「發展項目住宅物業不分割份數分配表」。

### C. 發展項目的管理人的委任年期

管理人的最初任期為由公契的日期起計兩年。管理人的任期可由管理人或業主委員會根據公契條款給予對方不少於三個月書面通知以終止。

### D. 管理開支按甚麼基準在發展項目中的住宅物業的擁有人之間分擔

屋苑的業主須按下列方式分攤管理開支：

- (a) 如任何開支涉及屋苑公用地方及/或屋苑公用設施，有關開支將計入整個屋苑的管理開支，並由屋苑所有業主按照有關的屋苑部分管理份數佔屋苑管理份數總額的比例分擔。
- (b) 儘管上述第(a)分段有所規定，(i) 凡任何開支純粹涉及或純粹為任何洋房的利益而設，及沒有其他業主(具獨家權利及特權持有、使用及佔用該洋房的業主除外)由此得到任何重大利益，該開支須全數由該洋房的業主承擔；及(ii) 凡任何開支純粹涉及或純粹為一組業主的利益而設，但並不涉及其他業主或並非為其他業主的利益而設，該開支須全數由該等業主按彼等各自管理份數的比例分攤。

### E. 計算管理費按金的基準

管理費按金為相當於三個月的管理費。

### F. 擁有人在發展項目中保留作自用的範圍(如有的話)

不適用。

### 發展項目住宅物業不分割份數分配表

1號洋房	770/ 2,549
2號洋房	779/ 2,549

#### 註：

- (1) 請參閱公契以了解全部詳情。完整的公契文本可於售樓處營業時間作出要求後免費查閱，並可在支付所需影印費後取得公契之複印本。
- (2) 除非另設定義，否則上述名詞具有公契中該等名詞的相同意義。

## SUMMARY OF LAND GRANT

### 批地文件的摘要

1. The Development is constructed on Tuen Mun Town Lot No.512 ("the Lot") which is held under New Grant No.21894 dated 24<sup>th</sup> September 2014 ("the Land Grant").
2. The Lot is granted for a term of 50 years commencing from 24<sup>th</sup> September 2014.
3. Special Condition No.(3) of the Land Grant stipulates that: -  
"The lot or any part thereof or any building or part of any building erected or to be erected thereon shall not be used for any purpose other than for private residential purposes."
4. General Condition No.5(c) of the Land Grant stipulates that: -  
"The Purchaser hereby indemnifies and shall keep indemnified the Government against all actions, proceedings, liabilities, demands, costs, expenses, losses (whether financial or otherwise) and claims whatsoever and howsoever arising from any breach of these Conditions or any damage or soil and groundwater contamination caused to adjacent or adjoining land or to the lot where such damage or soil and groundwater contamination has, in the opinion of the Director (whose opinion shall be final and binding on the Purchaser), arisen out of any use of the lot, or any development or redevelopment of the lot or part thereof or out of any activities carried out on the lot or out of any other works carried out thereon by the Purchaser whether or not such use, development or redevelopment, activities or works are in compliance with these Conditions or in breach thereof."
5. General Condition No.7(a) of the Land Grant stipulates that: -  
"The Purchaser shall throughout the tenancy having built or rebuilt (which word refers to redevelopment as contemplated in sub-clause (b) of this General Condition) in accordance with these Conditions:
  - (i) maintain all buildings in accordance with the approved design and disposition and any approved building plans without variation or modification thereto; and
  - (ii) maintain all buildings erected or which may hereafter be erected in accordance with these Conditions or any subsequent contractual variation of them, in good and substantial repair and condition and in such repair and condition deliver up the same at the expiration or sooner determination of the tenancy."
6. General Condition No.7(b) of the Land Grant stipulates that: -  
"In the event of the demolition at any time during the tenancy of any building then standing on the lot or any part thereof, the Purchaser shall replace the same either by sound and substantial building or buildings of the same type and of no less gross floor area or by building or buildings of such type and value as shall be approved by the Director. In the event of demolition as aforesaid, the Purchaser shall within one calendar month of such demolition apply to the Director for consent to carry out building works for the redevelopment of the lot and upon receiving such consent shall within three calendar months thereof commence the necessary works of redevelopment and shall complete the same to the satisfaction of and within such time limit as is laid down by the Director."
7. Special Condition No.(2) of the Land Grant stipulates that: -  
"The Purchaser shall develop the lot by the erection thereon of a building or buildings complying in all respects with these Conditions and all Ordinances, bye-laws and regulations relating to building, sanitation and planning which are or may at any time be in force in Hong Kong, such building or buildings to be completed and made fit for occupation on or before the 30<sup>th</sup> day of June 2019."
8. Special Condition No.(8) of the Land Grant stipulates that: -  
"No tree growing on the lot or adjacent thereto shall be removed or interfered with without the prior written consent of the Director who may, in granting consent, impose such conditions as to transplanting, compensatory landscaping or replanting as he may deem appropriate."
9. Special Condition No.(9)(a) of the Land Grant stipulates that: -  
"The Purchaser shall at his own expense submit to the Director for his approval a landscape plan indicating the location, disposition and layout of the landscaping works to be provided within the lot in compliance with the requirements stipulated in sub-clause (b) of this Special Condition."
10. Special Condition No.(9)(b) of the Land Grant stipulates that: -
  - (i) Not less than 20% of the area of the lot shall be planted with trees, shrubs or other plants.
  - (ii) Not less than 50% of the 20% referred to in sub-clause (b)(i) of this Special Condition (hereinafter referred to as "the Greenery Area") shall be provided at such location or level as may be determined by the Director at his sole discretion so that the Greenery Area shall be visible to pedestrians or accessible by any person or persons entering the lot.  
..."
11. Special Condition No.(9)(c) of the Land Grant stipulates that: -  
"The Purchaser shall at his own expense landscape the lot in accordance with the approved landscape plan in all respects to the satisfaction of the Director, and no amendment, variation, alteration, modification or substitution of the approved landscape plan shall be made without the prior written consent of the Director."
12. Special Condition No.(9)(d) of the Land Grant stipulates that: -  
"The Purchaser shall thereafter at his own expense maintain and keep the landscaped works in a safe, clean, neat, tidy and healthy condition all to the satisfaction of the Director."
13. Special Condition No.(9)(e) of the Land Grant stipulates that: -  
"The area or areas landscaped in accordance with this Special Condition shall be designated as and form part of the Common Areas referred to in Special Condition No.(15)(a)(v) hereof."
14. Special Condition No.(18)(a) of the Land Grant stipulates that: -
  - (i) Spaces shall be provided within the lot to the satisfaction of the Director for the parking of motor vehicles licensed under the Road Traffic Ordinance, any regulations made thereunder and any amending legislation, and belonging to the residents of the building or buildings erected or to be erected on the lot and their bona fide guests, visitors or invitees (hereinafter referred to as "the Residential Parking Spaces") at the following rates:  
...
    - (iii) Additional spaces shall be provided within the lot to the satisfaction of the Director for the parking of motor vehicles licensed under the Road Traffic Ordinance, any regulations made thereunder and any amending legislation, and belonging to the bona fide guests, visitors or invitees of the residents of the building or buildings erected or to be erected on the lot at the following rates or at such other rates as may be approved by the Director:  
...
      - (iv) The spaces provided under sub-clauses (a)(i)(I) (as may be varied under Special Condition No.(21) hereof), (a)(i)(II) and (a)(iii) (as may be varied under Special Condition No.(21) hereof) of this Special Condition shall not be used for any purpose other than those respectively stipulated therein and in particular the said spaces shall not be used for the storage, display or exhibiting of motor vehicles for sale or otherwise or for the provision of car cleaning and beauty services."
15. Special Condition No.(18)(b) of the Land Grant stipulates that: -
  - (i) Out of the spaces provided under sub-clauses (a)(i)(I) (as may be varied under Special Condition No.(21) hereof), (a)(i)(II) and (a)(iii) (as may be varied under Special Condition No.(21) hereof) of this Special Condition, the Purchaser shall reserve and designate such number of spaces for the parking of motor vehicles by disabled persons as defined in the Road Traffic Ordinance, any regulations made thereunder and any amending legislation (which spaces to be so reserved and designated are hereinafter referred to as "the Parking Spaces for the Disabled Persons") as the Building Authority may require and approve...
    - (ii) The Parking Spaces for the Disabled Persons shall be located at such position and level as shall be approved in writing by the Director.
    - (iii) The Parking Spaces for the Disabled Persons shall not be used for any purpose other than for the parking of motor vehicles by disabled persons as defined in the Road Traffic Ordinance, any regulations made thereunder and any amending legislation, and belonging to the residents of the building or buildings erected or to be erected on the lot and their bona fide guests, visitors or invitees and in particular the said spaces shall not be used for the storage, display or exhibiting of motor vehicles for sale or otherwise or for the provision of car cleaning and beauty services."
16. Special Condition No.(18)(c) of the Land Grant stipulates that: -
  - (i) Spaces shall be provided within the lot to the satisfaction of the Director for the parking of motor cycles licensed under the Road Traffic Ordinance, any regulations made thereunder and any amending legislation, and belonging to the residents of the building or buildings erected or to be erected on the lot and their bona fide guests, visitors or invitees (hereinafter referred to as "the Motor Cycle Parking Spaces") ...

## SUMMARY OF LAND GRANT

### 批地文件的摘要

- (ii) The Motor Cycle Parking Spaces shall not be used for any purpose other than for the purpose set out in sub-clause (c)(i) of this Special Condition and in particular the said spaces shall not be used for the storage, display or exhibiting of motor vehicles for sale or otherwise or for the provision of car cleaning and beauty services."
17. Special Condition No.(19)(a) of the Land Grant stipulates that: -  
"Spaces shall be provided within the lot to the satisfaction of the Director for the loading and unloading of goods vehicles..."
18. Special Condition No.(20) of the Land Grant stipulates that: -  
"Spaces shall be provided within the lot to the satisfaction of the Director for the parking of bicycles belonging to the residents of the building or buildings erected or to be erected on the lot and their bona fide guests, visitors or invitees..."
19. Special Condition No.(23)(a) of the Land Grant stipulates that: -  
"Notwithstanding that these Conditions shall have been observed and complied with to the satisfaction of the Director, the Residential Parking Spaces and the Motor Cycle Parking Spaces shall not be:
- (i) assigned except
- (I) together with undivided shares in the lot giving the right of exclusive use and possession of a residential unit or units in the building or buildings erected or to be erected on the lot; or
- (II) to a person who is already the owner of undivided shares in the lot with the right of exclusive use and possession of a residential unit or units in the building or buildings erected or to be erected on the lot; or
- (ii) underlet except to residents of the residential units in the building or buildings erected or to be erected on the lot.
- Provided that in any event not more than three in number of the total of the Residential Parking Spaces and the Motor Cycle Parking Spaces shall be assigned to the owner or underlet to the resident of any one residential unit in the building or buildings erected or to be erected on the lot. "
20. Special Condition No.(25) of the Land Grant stipulates that: -  
"A plan approved by the Director indicating the layout of all the parking, loading and unloading spaces to be provided within the lot in accordance with Special Conditions Nos.(18) (as may be varied under Special Condition No.(21) hereof), (19) and (20) hereof, or a copy of such plan certified by an authorized person (as defined in the Buildings Ordinance, any regulations made thereunder and any amending legislation) shall be deposited with the Director... The parking, loading and unloading spaces indicated on the said approved plan shall not be used for any purpose other than for the purposes set out respectively in Special Conditions Nos.(18), (19) and (20) hereof. The Purchaser shall maintain the parking, loading and unloading spaces and other areas, including but not restricted to the lifts, landings and manoeuvring and circulation areas, in accordance with the said approved plan and shall not alter the layout except with the prior written consent of the Director. Except for the parking spaces indicated on the said approved plan, no part of the lot or any building or structure thereon shall be used for parking purposes."
21. Special Condition No.(27)(a) of the Land Grant stipulates that: -  
"The lot is granted together with a right for the Purchaser and his servants, visitors, workmen and other persons authorized by the Purchaser in that behalf from time to time and at all times during the term hereby agreed to be granted for all purposes connected with the proper use and enjoyment of the lot to pass and repass, on, along, over, by and through the area shown coloured brown on the plan annexed hereto (hereinafter referred to as "the Brown Area") at such levels as may be approved by the Director."
22. Special Condition No.(27)(b) of the Land Grant stipulates that: -  
"The Purchaser shall within 54 calendar months from the date of this Agreement (or within such other extended period as may be approved by the Director), at his own expense, in such manner, with such materials and to such standards as the Director shall require or approve, construct a paved way with the associated street furniture, traffic aids, street lighting, sewers, drains and other structures on the Brown Area over and along which a right of way referred to in sub-clause (a) of this Special Condition is given with minimum disturbance to the owners of any other lots in the vicinity to whom rights of way over the whole or any portion of the Brown Area may have been granted."
23. Special Condition No.(27)(c) of the Land Grant stipulates that: -  
"(i) The Purchaser shall within 24 calendar months from the date of this Agreement (or such other extended period as may be approved by the Director), at his own expense and in all respects to the satisfaction of the Director submit or cause to be submitted to the Director for his approval in writing a slope stability assessment (hereinafter referred to as "SSA") containing, among others, such information and particulars as the Director may require including but not limited to the slope stability assessment of the Brown Area and the area adjacent thereto and recommendations for mitigation measures, improvement works and other measures and works.
- (ii) The Purchaser shall within 54 calendar months from the date of this Agreement (or such other extended period as may be approved by the Director), at his own expense implement the recommendations in the approved SSA in all respects to the satisfaction of the Director.
- (iii) For the avoidance of doubt and without prejudice to the generality of General Condition No.5 hereof, the Purchaser hereby expressly acknowledges and agrees that he shall have the sole responsibility at his own expense to implement the recommendations in the approved SSA in all respects to the satisfaction of the Director. The Government and its officers shall be under no responsibility, obligation or liability whatsoever to the Purchaser for any cost, damage or loss caused to or suffered by the Purchaser whether arising out of or incidental to the fulfilment of the Purchaser's obligations under this Special Condition or otherwise, and no claim whatsoever shall be made against the Government or its officers by the Purchaser in respect of any such cost, damage or loss."
24. Special Condition No.(27)(d) of the Land Grant stipulates that: -  
"The Purchaser shall at his own expense uphold, maintain and repair the Brown Area and everything forming a portion of or pertaining to it, all to be done to the satisfaction of the Director, and the Purchaser shall be responsible for the whole as if he were the absolute owner thereof."
25. Special Condition No.(27)(e) of the Land Grant stipulates that: -  
"Any alternation to any public road absorbing a portion of the Brown Area over and along which a right of way is given or affecting the gradient thereof shall not give rise to any claim whatsoever by the Purchaser who shall at his own expense carry out all consequent alterations to the paved way constructed by him to the satisfaction of the Director."
26. Special Condition No.(27)(f) of the Land Grant stipulates that: -  
"The grant of the right of way referred to in sub-clause (a) of this Special Condition shall not give the Purchaser the exclusive right over the Brown Area. The Government shall have the right to grant rights of way over the Brown Area to the owners of any other lots in the vicinity now or at any time in the future, or to take over the whole or any portion of the Brown Area for the purposes of a public street without payment of any compensation to the Purchaser or to other owners to whom rights of way over the whole or any portion of the Brown Area may have been granted."
27. Special Condition No.(27)(g) of the Land Grant stipulates that: -  
"In the event of the non-fulfilment of the Purchaser's obligations under sub-clauses (b), (c) and (d) of this Special Condition, the Government may carry out the necessary works at the cost of the Purchaser who shall pay to the Government on demand a sum equal to the cost thereof, such sum to be determined by the Director whose determination shall be final and binding upon the Purchaser."
28. Special Condition No.(27)(h) of the Land Grant stipulates that: -  
"Notwithstanding the grant of the right of way referred to in sub-clause (a) of this Special Condition, the Government shall have the full right and power, upon giving to the Purchaser not less than fourteen days' written notice (save in case of emergency) to lay, install, relay, divert, remove, re-provision, replace, inspect, operate, repair, maintain and renew any Government or other drain, culvert, waterway or watercourse, sewer, nullah, water main, pipe, cable, wire, line, utility service or other works or installations (all together hereinafter referred to as "the Brown Area Services") which are now or may hereafter be upon, over, under or adjacent to the Brown Area as the Director may in his absolute discretion deem fit, making good any and all damage caused thereby, and the Government, the Director and his officers, contractors and agents and any persons authorized by the Director, his or their workmen with or without tools, equipment, plant, machinery or motor vehicles shall have the right of free and unrestricted ingress, egress and regress at all times to, from and through the Brown Area for the purposes aforesaid. The Purchaser shall not disturb or allow anybody to disturb the Brown Area Services without the prior written approval from the Director. Save in respect of making good any and all

## SUMMARY OF LAND GRANT

### 批地文件的摘要

damage caused by any exercise of the aforesaid rights and powers, the Government, the Director and his officers, contractors and agents and any persons authorized by the Director, his or their workmen shall have no liability in respect of any loss, damage, nuisance or disturbance whatsoever caused to or suffered by the Purchaser arising out of or incidental to the exercise of the rights conferred under this sub-clause (h), and no claim nor objection whatsoever shall be made against him or them by the Purchaser."

29. Special Condition No.(28) of the Land Grant stipulates that: -

"The Purchaser shall not cut away, remove or set back any Government land adjacent to or adjoining the lot or carry out any building-up, filling-in or any slope treatment works of any kind whatsoever on any Government land except with the prior written consent of the Director who may, at his sole discretion, give his consent subject to such terms and conditions as he sees fit, including the grant of additional Government land as an extension to the lot at such premium as he may determine."

30. Special Condition No.(29)(a) of the Land Grant stipulates that: -

"Where there is or has been any cutting away, removal or setting back of any land, or any building-up or filling-in or any slope treatment works of any kind whatsoever, whether with or without the prior written consent of the Director, either within the lot or on any Government land, which is or was done for the purpose of or in connection with the formation, levelling or development of the lot or any part thereof or any other works required to be done by the Purchaser under these Conditions, or for any other purpose, the Purchaser shall at his own expense carry out and construct such slope treatment works, retaining walls or other support, protection, drainage or ancillary or other works as shall or may then or at any time thereafter be necessary to protect and support such land within the lot and also any adjacent or adjoining Government or leased land and to obviate and prevent any falling away, landslip or subsidence occurring thereafter. The Purchaser shall at all times during the term hereby agreed to be granted maintain at his own expense the said land, slope treatment works, retaining walls or other support, protection, drainage or ancillary or other works in good and substantial repair and condition to the satisfaction of the Director."

31. Special Condition No.(29)(c) of the Land Grant stipulates that: -

"In the event that as a result of or arising out of any formation, levelling, development or other works done by the Purchaser or owing to any other reason, any falling away, landslip or subsidence occurs at any time, whether in or from any land, within the lot or from any adjacent or adjoining Government or leased land, the Purchaser shall at his own expense reinstate and make good the same to the satisfaction of the Director and shall indemnify the Government, its agents and contractors from and against all costs, charges, damages, demands and claims whatsoever which shall or may be made, suffered or incurred through or by reason of such falling away, landslip or subsidence."

32. Special Condition No.(29)(d) of the Land Grant stipulates that: -

"In addition to any other rights or remedies herein provided for breach of any of these Conditions, the Director shall be entitled by notice in writing to call upon the Purchaser to carry out, construct and maintain the said land, slope treatment works, retaining walls, or other support, protection, and drainage or ancillary or other works or to reinstate and make good any falling away, landslip or subsidence, and if the Purchaser shall neglect or fail to comply with the notice to the satisfaction of the Director within the period specified therein, the Director may forthwith execute and carry out any necessary works and the Purchaser shall on demand repay to the Government the cost thereof, together with any administrative or professional fees and charges."

33. Special Condition No.(30) of the Land Grant stipulates that: -

"Where prestressed ground anchors have been installed, upon development or redevelopment of the lot or any part thereof, the Purchaser shall at his own expense carry out regular maintenance and regular monitoring of the prestressed ground anchors throughout their service life to the satisfaction of the Director and shall supply to the Director such reports and information on all such monitoring works as the Director may from time to time in his absolute discretion require. If the Purchaser shall neglect or fail to carry out the required monitoring works, the Director may forthwith execute and carry out the monitoring works and the Purchaser shall on demand repay to the Government the cost thereof."

34. Special Condition No.(31)(a) of the Land Grant stipulates that: -

"In the event of earth, spoil, debris, construction waste or building materials (hereinafter referred to as "the waste") from the lot, or from other areas affected by any development of the lot being eroded,

washed down or dumped onto public lanes or roads or into or onto road-culverts, foreshore or seabed, sewers, storm-water drains or nullahs or other Government properties (hereinafter referred to as "the Government properties"), the Purchaser shall at his own expense remove the waste from and make good any damage done to the Government properties. The Purchaser shall indemnify the Government against all actions, claims and demands arising out of any damage or nuisance to private property caused by such erosion, washing down or dumping."

35. Special Condition No.(32) of the Land Grant stipulates that: -

"The Purchaser shall take or cause to be taken all proper and adequate care, skill and precautions at all times, and particularly when carrying out construction, maintenance, renewal or repair work (hereinafter referred to as "the Works"), to avoid causing any damage, disturbance or obstruction to any Government or other existing drain, waterway or watercourse, water main, road, footpath, street furniture, sewer, nullah, pipe, cable, wire, utility service or any other works or installations being or running upon, over, under or adjacent to the lot or any part thereof or the Brown Area or both the lot or any part thereof and the Brown Area (hereinafter collectively referred to as "the Services"). The Purchaser shall prior to carrying out any of the Works make or cause to be made such proper search and enquiry as may be necessary to ascertain the present position and levels of the Services, and shall submit his proposals for dealing with any of the Services which may be affected by the Works in writing to the Director for his approval in all respects, and shall not carry out any work whatsoever until the Director shall have given his written approval to the Works and to such aforesaid proposals. The Purchaser shall comply with and at his own expense meet any requirements which may be imposed by the Director in respect of the Services in granting the aforesaid approval, including the cost of any necessary diversion, relaying or reinstatement. The Purchaser shall at his own expense in all respects repair, make good and reinstate to the satisfaction of the Director any damage, disturbance or obstruction caused to the lot or any part thereof or the Brown Area or both the lot or any part thereof and the Brown Area or any of the Services in any manner arising out of the Works (except for nullah, sewer, storm-water drain or water main, the making good of which shall be carried out by the Director, unless the Director elects otherwise, and the Purchaser shall pay to the Government on demand the cost of such works). If the Purchaser fails to carry out any such necessary diversion, relaying, repairing, making good and reinstatement of the lot or any part thereof or the Brown Area or both the lot or any part thereof and the Brown Area or of any of the Services to the satisfaction of the Director, the Director may carry out any such diversion, relaying, repairing, making good or reinstatement as he considers necessary and the Purchaser shall pay to the Government on demand the cost of such works."

36. Special Condition No.(33)(a) of the Land Grant stipulates that: -

"(i) The Purchaser hereby acknowledges that as at the date of this Agreement, there are existing within the lot underground electricity devices (hereinafter referred to as "the Devices") laid by CLP Power Hong Kong Limited (hereinafter referred to as "CLP").

(ii) Without prejudice to the generality of the provisions of General Condition No.5 hereof, the Purchaser shall be deemed to have satisfied himself as to and have accepted the state and condition of the lot as existing at the date of this Agreement subject to the presence of the Devices and no objection or claim whatsoever shall be made or raised by the Purchaser in respect of or on account of the same."

37. Special Condition No.(33)(b) of the Land Grant stipulates that: -

"(i) The Purchaser shall not at any time during the term hereby agreed to be granted interfere with or obstruct or remove or relocate or permit or suffered to be interfered with or obstructed or removed or relocated the Devices except with the prior written consent of CLP.

(ii) The Purchaser shall take or cause to be taken all proper and adequate care, skills and precautions at all times and particularly when carrying out any works within or adjacent to the lot to avoid causing any damage, disturbance or interference to the Devices. ..."

38. Special Condition No.(33)(c) of the Land Grant stipulates that: -

"The Purchaser shall permit CLP, its contractors, workmen and agents and any persons authorized by CLP, the right of free and unrestricted ingress, egress and regress to, from and through the lot or any part thereof at all reasonable times with or without tools, equipment, plant, machinery or motor vehicles for the purposes of inspecting, checking, renewing and carrying out any works to the Devices which CLP may consider necessary."

## SUMMARY OF LAND GRANT

### 批地文件的摘要

39. Special Condition No.(34)(a) of the Land Grant stipulates that: -  
"The Purchaser shall construct and maintain at his own expense and to the satisfaction of the Director such drains and channels, whether within the boundaries of the lot or on Government land, as the Director may consider necessary to intercept and convey into the nearest stream-course, catchpit, channel or Government storm-water drain all storm-water or rain-water falling or flowing on to the lot, and the Purchaser shall be solely liable for and shall indemnify the Government and its officers from and against all actions, claims and demands arising out of any damage or nuisance caused by such storm-water or rain-water."
40. Special Condition No.(34)(b) of the Land Grant stipulates that: -  
"The works of connecting any drains and sewers from the lot to the Government storm-water drains and sewers, when laid and commissioned, may be carried out by the Director who shall not be liable to the Purchaser for any loss or damage thereby occasioned and the Purchaser shall pay to the Government on demand the cost of such connection works. Alternatively, the said connection works may be carried out by the Purchaser at his own expense to the satisfaction of the Director and in such case any section of the said connection works which is constructed within Government land shall be maintained by the Purchaser at his own cost and upon demand be handed over by the Purchaser to the Government for future maintenance thereof at the expense of the Government and the Purchaser shall pay to the Government on demand the cost of the technical audit in respect of the said connection works. The Director may, upon failure of the Purchaser to maintain any section of the said connection works which is constructed within Government land, carry out such maintenance works as he considers necessary and the Purchaser shall pay to the Government on demand the cost of such works."
41. Special Condition No.(35)(a) of the Land Grant stipulates that: -  
"Fresh water from Government mains shall not be used for flushing purposes except with the prior written consent of the Director of Water Supplies."
42. Special Condition No.(35)(b) of the Land Grant stipulates that: -  
"Notwithstanding sub-clause (a) of this Special Condition, consent to use fresh water for flushing may be given by the Director of Water Supplies provided that the Purchaser shall at his own expense install salt water plumbing and accept salt water supply when it is available in the future..."
43. Special Condition No.(35)(c) of the Land Grant stipulates that: -  
"There is no guarantee from the Government that salt water supply shall be available in the future..."
44. Special Condition No.(36)(a) of the Land Grant stipulates that: -  
(i) The Purchaser hereby expressly acknowledges and accepts that there are no Government sewers in the vicinity available for connection to the lot as at the date of this Agreement.  
(ii) The Purchaser shall at his own expense construct and provide within the lot sewerage treatment works and disposal facilities (hereinafter referred to as "the Sewerage Treatment Works and Disposal Facilities") at such locations, with such materials and to such standards in all respects to the satisfaction of the Director. The Purchaser shall thereafter at his own expense operate, maintain and repair the Sewerage Treatment Works and Disposal Facilities to the satisfaction of the Director."
45. Special Condition No.(36)(b) of the Land Grant stipulates that: -  
"When Government sewers are laid and made available in the vicinity of the lot, the Purchaser shall at his own expense and in all respects to the satisfaction of the Director alter the sewers or construct new sewers within the lot or both in such manner, with such materials and to such standards in all respects to the satisfaction of the Director for the purpose of connecting the same to the Government sewers."
46. Special Condition No.(36)(c) of the Land Grant stipulates that: -  
"The Purchaser shall, after completion of the works for connecting the sewers within the lot to the Government sewers as referred to in sub-clause (b) of this Special Condition and Special Condition No.(34) hereof, demolish and remove at his own expense the Sewerage Treatment Works and Disposal Facilities upon the request of the Director provided that such demolition and removal shall be effected and completed in all respects to the satisfaction of the Director."
47. Special Condition No.(36)(e) of the Land Grant stipulates that: -  
"Prior to the demolition and removal of the Sewerage Treatment Works and Disposal Facilities referred to in sub-clause (c) of this Special Condition, the Government, the Director and his officers, contractors and agents and any persons authorized by the Director, his or their workmen with or without tools, equipment, plant, machinery or motor vehicles shall have the right of free and unrestricted ingress, egress and regress to, from and through the lot or any part thereof at all times for the purposes of inspecting, sampling, testing, gauging, making measurements, taking records of the Sewerage Treatment Works and Disposal Facilities..."
48. Special Condition No.(37)(a) of the Land Grant stipulates that: -  
(i) The Purchaser hereby acknowledges that as at the date of this Agreement, there are drains, sewers, channels, drainage facilities and other services running across, through or under the Drainage Reserve Area referred to in Special Condition No.(37)(b)(i) hereof (hereinafter collectively referred to as "the Utilities").  
(ii) Without prejudice to the generality of the provisions of General Condition No.5 hereof, the Purchaser shall be deemed to have satisfied himself as to and have accepted the state and condition of the lot as existing at the date of this Agreement subject to the presence of the Utilities and no objection or claim whatsoever shall be made or raised by the Purchaser in respect of or on account of the same.  
..."
49. Special Condition No.(37)(b) of the Land Grant stipulates that: -  
(i) No building, structure, or support for any building or structure shall be erected or constructed or placed on, over, above, under, below or within that portion of the lot shown coloured pink hatched black and marked "D.R." on the plan annexed hereto (hereinafter referred to as "the Drainage Reserve Area") except projection over the Drainage Reserve Area provided that there is a clear air space extending upwards from the ground level or levels within the Drainage Reserve Area to a height of more than 6 meters..."
50. Special Condition No.(37)(c) of the Land Grant stipulates that: -  
"Throughout the term hereby agreed to be granted, the Government, the Director and his officers, contractors and agents and any persons authorized by the Director, his or their workmen with or without tools, equipment, plant, machinery or motor vehicles shall have the right of free and unrestricted ingress, egress and regress to, from and through the lot or any part thereof at all times for the purposes of laying, inspecting, repairing, maintaining, replacing and renewing the Utilities or any part thereof which the Director may require or authorize. No object or material of whatsoever nature which may obstruct access or cause excessive surcharge to the Utilities shall be placed within the Drainage Reserve Area. Where in the opinion of the Director (whose opinion shall be final and binding on the Purchaser), there are objects or material within the Drainage Reserve Area which may obstruct access or cause excessive surcharge to the Utilities, the Director shall be entitled by notice in writing to call upon the Purchaser, at his own expense and in all respects to the satisfaction of the Director, to demolish or remove such objects or material and to reinstate the Drainage Reserve Area. If the Purchaser shall neglect or fail to comply with such notice within the time limit specified therein or as required in any emergency, the Director may carry out such demolition, removal and reinstatement works as he may consider necessary and the Purchaser shall pay to the Government on demand a sum equal to the cost of such works, such sum to be determined by the Director whose determination shall be final and binding on the Purchaser."
51. Special Condition No.(38)(a) of the Land Grant stipulates that: -  
"The Purchaser shall within six calendar months from the date of this Agreement (or such other extended period as may be approved by the Director), at his own expense and in all respects to the satisfaction of the Director of Environmental Protection submit or cause to be submitted to the Director of Environmental Protection for his approval in writing a sewerage impact assessment (hereinafter referred to as "SIA") containing, among others, such information and particulars as the Director of Environmental Protection may require including but not limited to all adverse sewerage impact as may arise from the development of the lot, the sewage flow from all other planned and committed development in the same catchment, and recommendations for mitigation measures, improvement works and other measures and works."
52. Special Condition No.(38)(b) of the Land Grant stipulates that: -  
"The Purchaser shall at his own expense and within such time limits as shall be stipulated by the Director of Environmental Protection implement the recommendations in the approved SIA in all respects to the satisfaction of the Director of Environmental Protection."
53. Special Condition No.(39)(a) of the Land Grant stipulates that: -  
"The Purchaser shall within six calendar months from the date of this Agreement (or such other extended period as may be approved by the Director), at his own expense and in all respects to the satisfaction of the Director of Drainage Services submit or cause to be submitted to

## SUMMARY OF LAND GRANT

### 批地文件的摘要

the Director of Drainage Services for his approval in writing a drainage impact assessment (hereinafter referred to as "DIA") containing, among others, such information and particulars as the Director of Drainage Services may require including but not limited to all adverse drainage impact as may arise from the development of the lot, and recommendations for mitigation measures, improvement works and other measures and works (hereinafter collectively referred to as "the Drainage Mitigation Measures")."

54. Special Condition No.(39)(b) of the Land Grant stipulates that: -

"The Purchaser shall at his own expense and within such time limits as shall be stipulated by the Director of Drainage Services implement the recommendations in the approved DIA in all respects to the satisfaction of the Director of Drainage Services."

55. Special Condition No.(39)(d) of the Land Grant stipulates that: -

"(i) Without prejudice to the generality of the provisions of sub-clause (b) of this Special Condition, the Purchaser shall if so required by the Director of Drainage Services, at his own expense and within such time limits as shall be stipulated by the Director of Drainage Services provide, construct and erect an underground flood water storage tank or similar facilities (hereinafter referred to as "the Underground Flood Water Storage Tank") within the lot as part of the Drainage Mitigation Measures in all respects to the satisfaction of the Director of Drainage Services.

(ii) The Purchaser shall thereafter at all times and at his own expense maintain the Underground Flood Water Storage Tank in all respects to the satisfaction of the Director of Drainage Services and shall ensure that there shall be no adverse drainage impact to the areas affected by both upstream and downstream of the drainage system.

..."

56. Special Condition No.(40)(a) of the Land Grant stipulates that: -

"Without prejudice to the generality of the provisions of General Condition No.5 hereof, the Purchaser hereby acknowledges that the lot is close to the shoreline and that as a result, the lot may be subject to tidal and wave actions."

57. Special Condition No.(40)(b) of the Land Grant stipulates that: -

"The Purchaser shall at his own expense and within such time limits as shall be stipulated by the Director of Civil Engineering and Development design, erect, construct and provide within the lot seawall and marine structures in accordance with the Port Works Design Manual published by the Civil Engineering and Development Department and any requirements imposed by the Director of Civil Engineering and Development at his sole discretion in all respects to the satisfaction of the Director of Civil Engineering and Development to protect the lot from any tidal and wave actions. The Purchaser shall thereafter at all times and at his own expense maintain the seawall and marine structures in all respects to the satisfaction of the Director of Civil Engineering and Development. For the purpose of this sub-clause (b), the decision of the Director of Civil Engineering and Development as to what constitutes seawall and marine structures shall be final and binding on the Purchaser."

58. Special Condition No.(40)(c) of the Land Grant stipulates that: -

"The Purchaser hereby expressly acknowledges and accepts that all additional costs, charges, fees and expenses whatsoever, whether in respect of any works taken to protect or remedy the lot from and against any loss or damage arising out of or in connection with the lot being close to the shoreline or the lot being subject to any tidal and wave actions, shall be the Purchaser's sole responsibility and that the Government shall be under no liability to the Purchaser, his successors or assigns in respect of such costs, charges, fees and expenses."

59. Special Condition No.(40)(d) of the Land Grant stipulates that: -

"The Purchaser for and on behalf of himself, his successors and assigns expressly waives any and all claims which he or they might have against the Government as a result of or arising out of the lot being close to the shoreline or the lot being subject to any tidal and wave actions, and releases the Government from any and all liabilities which may arise, as a result of or arising out of the lot being close to the shoreline or the lot being subject to any tidal and wave actions..."

60. Special Condition No.(41)(a) of the Land Grant stipulates that: -

"The Purchaser shall have no right of access to the sea from the lot and from the sea to the lot."

61. Special Condition No.(41)(b) of the Land Grant stipulates that: -

"The Government reserves the right to reclaim the foreshore to seaward of the lot at any time and the Purchaser shall have no right

to any compensation whatsoever whether under the Foreshore and Sea-bed (Reclamations) Ordinance, any regulations made thereunder and any amending legislation or otherwise in respect of any such reclamation."

62. Special Condition No.(44) of the Land Grant stipulates that: -

"No grave or columbarium shall be erected or made on the lot, nor shall any human remains or animal remains whether in earthenware jars, cinerary urns or otherwise be interred therein or deposited thereon."

Notes:

1. The expression "Purchaser" under the Land Grant, where the context so admits or requires, includes his executors, administrators and assigns and in case of a corporation its successors and assigns.
2. Please refer to the Land Grant for full details. A copy of the Land Grant is available for inspection free of charge during opening hours at the sales office upon request and copies will be provided on payment of photocopying charges.

# SUMMARY OF LAND GRANT

## 批地文件的摘要

1. 發展項目興建於依據日期為2014年9月24日的新批土地契約第21894號(「**批地文件**」)而持有的屯門市地段第512號(「**該地段**」)上。
2. 該地段批地年期為由2014年9月24日起計50年。
3. 批地文件特別條件第(3)條規定：

「該地段或其任何部分或在其上現存或擬建的任何建築物或其部分不得作私人住宅用途以外用途。」
4. 批地文件一般條件第5(c)條規定：

「買方須就任何違反該等條件或署長認為(其意見為最終並對買方有約束力)任何因買方使用該地段、或任何開發或重建該地段或其部分、或在該地段上進行的任何活動或在該地段上進行的任何其他工程(不論該等使用、開發或重建、活動或工程是否符合或違反該等條件)而引致毗鄰或毗連土地或該地段損壞或土壤及地下水污染,不論直接或間接所引起或與之有關的一切訴訟、法律程序、責任、要求、開支、支出、損失(不論是經濟或其他性質)和索償(不論任何及如何引致)向政府作出彌償及使其獲得彌償。」
5. 批地文件一般條件第7(a)條規定：

「買方須於批地年期的期間按該等條件對已建或重建建築物(該詞指本一般條件第(b)分條所指的重建)：

  - (i) 按經批准的設計、配置及任何經批准建築圖則維持一切建築物,不得對其作出修訂或更改;及
  - (ii) 維持已建或此後按該等條件或任何其後的合同性修改興建的一切建築物處於修繕妥當及良好的保養狀態直至批地年期結束或提前終止而交還為止。」
6. 批地文件一般條件第7(b)條規定：

「倘若在批地年期期間的任何時候拆卸當時在該地段或其任何部分上面的任何建築物,買方須興建相同類型和不少於現有總樓面面積並且健全及堅固的建築物或經署長批准的類型和價值的建築物作為替代。如果作出上述拆卸,買方須在上述拆卸的一個曆月內向署長申請批准進行該地段的重建,並在收到上述批准後的3個曆月內展開重建所必要的工程,及在達至署長滿意程度的情況下及署長規定的期限內完成工程。」
7. 批地文件特別條件第(2)條規定：

「買方須履行該等條件及遵守一切不時適用於香港有關建築物、衛生及規劃的法律法規,於該地段上興建建築物以發展該地段,該等建築物須於2019年6月30日或之前建成並適宜佔用。」
8. 批地文件特別條件第(8)條規定：

「除獲署長事先書面同意外(署長於簽發同意書時可施加其認為適當的移植、補償美化或重植條件),買方不得移除或干擾於該地段或鄰近地方生長的樹木。」
9. 批地文件特別條件第(9)(a)條規定：

「買方須自費將園景設計圖呈交署長審批,園景設計圖須標明將在該地段提供及符合本特別條件第(b)分條要求的園景工程的位置、規劃及佈局。」
10. 批地文件特別條件第(9)(b)條規定：

「(i) 該地段中不少於20%的範圍須種植樹木、灌木或其他植物。

(ii) 從本特別條件第(b)(i)分條提及的20%中保留不少於50%範圍(下稱「**綠化區域**」)在署長全權酌情決定的位置或水平提供,以便行人可看見或進入該地段的任何人士可接近該綠化區域。

...」
11. 批地文件特別條件第(9)(c)條規定：

「買方須自費依照獲批准的園景設計圖於該地段進行園景工程,並在各方面達致署長滿意及未經署長事先書面同意前,不得修改、變動、更改、修訂或取代獲批准的園景設計圖。」
12. 批地文件特別條件第(9)(d)條規定：

「買方往後須自費維護及維持該等園景工程,使其安全、整潔、整齊、井然及健康,並在各方面達致署長滿意。」
13. 批地文件特別條件第(9)(e)條規定：

「遵照本特別條件進行園境美化的一個或多個地方將劃為並且構成批地文件特別條件第(15)(a)(v)條訂明的「**公用地方**」。」
14. 批地文件特別條件第(18)(a)條規定：

「(i) 買方須於該地段內按指定比率提供停車位,供根據道路交通條例、其附屬規例及任何修訂法例發牌並屬於該地段現存或擬建建築物的住戶及其真正客人、訪客或獲邀請人士之車輛停泊(下稱「**住宅車位**」),以達致署長滿意：

...

(iii) 買方須於該地段內按指定比率(或署長批准的另一比率)提供額外停車位,供根據道路交通條例、其附屬規例及任何修訂法例發牌並屬於該地段現存或擬建建築物的住戶及其真正客人、訪客或獲邀請人士之車輛停泊,以達致署長滿意：

...

(iv) 根據本特別條件第(a)(i)(I)(可按批地文件特別條件第(21)條修訂)、第(a)(i)(II)及(a)(iii)(可按批地文件特別條件第(21)條修訂)分條提供的停車位不得作分別於該些特別條件分條內所規定以外的其他用途,尤其不得用作存放、展示或展覽車輛以供出售或其他用途,或用作提供汽車清潔及美容服務。」
15. 批地文件特別條件第(18)(b)條規定：

「(i) 在根據本特別條件第(a)(i)(I)(可按批地文件特別條件第(21)條修訂)、第(a)(i)(II)及(a)(iii)(可按批地文件特別條件第(21)條修訂)分條提供的停車位中,買方須保留及指定建築事務監督規定及批准之數量的供道路交通條例、其附屬規例及任何修訂法例界定的傷殘人士停泊車輛之車位(該將被保留及指定的停車位下稱「**傷殘人士車位**」)...

(ii) 傷殘人士車位須位於署長書面批准的地點和樓層。

(iii) 傷殘人士車位除用作停泊根據道路交通條例、其附屬規例及任何修訂法例界定的傷殘人士,及屬於該地段現存或擬建建築物的住戶及其真正客人、訪客或獲邀請人士之車輛外,不得作其他用途,尤其不得用作存放、展示或展覽車輛以供出售或其他用途,或用作提供汽車清潔及美容服務。」
16. 批地文件特別條件第(18)(c)條規定：

「(i) 買方須於該地段內提供停車位,供根據道路交通條例、其附屬規例及任何修訂法例發牌並屬於該地段現存或擬建建築物的住戶及其真正客人、訪客或獲邀請人士之電單車停泊(下稱「**電單車車位**」),以達致署長滿意...

(ii) 電單車車位不得作本特別條件第(c)(i)分條內所規定以外的其他用途,尤其該停車位不得用作存放、展示或展覽車輛以供出售或其他用途,或用作提供汽車清潔及美容服務。」
17. 批地文件特別條件第(19)(a)條規定：

「買方須於該地段內提供停車位供貨車裝卸,以達致署長滿意...」
18. 批地文件特別條件第(20)條規定：

「買方須於該地段內提供停車位供屬於該地段現存或擬建建築物的住戶及其真正客人、訪客或獲邀請人士之單車停泊,以達致署長滿意...」
19. 批地文件特別條件第(23)(a)條規定：

「即使已履行與遵守該等條件達致署長滿意,住宅車位及電單車車位不得：

  - (i) 轉讓,除非
    - (I) 連同該地段附有該地段現存或擬建建築物的住宅單位的專用權及管有權的不分割份數一同轉讓;或
    - (II) 轉讓予一名已擁有該地段附有該地段現存或擬建建築物的住宅單位的專用權及管有權的不分割份數的人士;或

# SUMMARY OF LAND GRANT

## 批地文件的摘要

(ii) 出租，除非出租予該地段現存或擬建建築物的住宅單位的住戶。

但是，在任何情況下，不得轉讓予該地段現存或擬建建築物的任何一個住宅單位的業主或出租予任何一個住宅單位的住戶總數多於3個住宅車位及電單車車位。」

20. 批地文件特別條件第(25)條規定：

「經署長批准根據批地文件特別條件第(18) (可按批地文件特別條件第(21)條修訂)、(19)及(20)條標示在該地段內提供的所有停車位、裝卸車位的所在位置的圖則或認可人士(根據建築物條例、其附屬規例及任何修訂法例界定)核實的該圖則副本須提交給署長...上述經批准圖則標示的停車位及裝卸車位不可用作批地文件特別條件第(18)、(19)及(20)條指定用途之外的用途。買方須根據該經批准圖則保養停車位、裝卸車位及其他區域，包括但不限於升降機、梯台、調度及迴旋區，未經署長事先書面批准，不得對其位置作出更改。除經批准圖則標示的停車位外，不得使用該地段或其中任何建築物或結構物作泊車用途。」

21. 批地文件特別條件第(27)(a)條規定：

「買方與其受傭人、訪客、工人及其他買方授權代表人士可於批地年期內不時及時刻為着達致完善使用及享用該地段的所有事宜在署長批准之水平進出、往返及經越於批地文件附錄圖則上以棕色顯示的範圍(下稱「棕色範圍」)

22. 批地文件特別條件第(27)(b)條規定：

「買方須於本協議的日期起計54個曆月內，或署長可批准的其他延長期限內，根據署長要求或批准的標準、物料及方式在本特別條件第(a)分條下給予通行權的棕色範圍自費興建鋪築路面道路及相關的街道設施、交通輔助設施、街燈、污水管、排水渠及其他結構物，並對附近可能已獲得全部或部分棕色範圍通行權之其他土地擁有人造成最少干擾。」

23. 批地文件特別條件第(27)(c)條規定：

「(i) 買方須於本協議的日期起計24個曆月內，或署長可批准的其他延長期限內，自費提交或促使他人提交斜坡穩定性評估(下稱「斜坡穩定性評估」)予署長書面審批，以在各方面達致署長滿意。斜坡穩定性評估須包含署長可能需要的資料及詳情，包括但不限於棕色範圍及鄰近地方的斜坡穩定性評估，以及緩解措施、改善工程及其他措施和工程的建議。

(ii) 買方須於本協議的日期起計54個曆月內，或署長可批准的其他延長期限內，自費實施經審批的斜坡穩定性評估內的建議，以在各方面達致署長滿意。

(iii) 為免存疑和在毋損批地文件一般條件第5條概括性的情況下，買方特此明示確認及同意他須獨自負責自費實施經審批的斜坡穩定性評估內的建議，以在各方面達致署長滿意。政府及其人員對買方因履行本特別條件或其他條款的責任所引起或附帶所引起的任何費用、損害或損失毋須承擔任何責任或義務。買方亦無權就上述費用、損害或損失向政府或其人員作出索償。」

24. 批地文件特別條件第(27)(d)條規定：

「買方須自費保養、維修及修理棕色範圍及所有附屬該處和與該處有關的物件，以達致署長滿意。買方將對該處全部負責，猶如該處的絕對擁有人一樣。」

25. 批地文件特別條件第(27)(e)條規定：

「對於公路更改工程所導致覆蓋部分買方獲授通行權的棕色範圍或影響該處之坡度，買方不得就此提出索償。買方須自費進行由其興建的鋪築路面道路的其後更改工程，以達致署長滿意。」

26. 批地文件特別條件第(27)(f)條規定：

「根據本特別條件第(a)分條所授予的通行權並不向買方授予棕色範圍的獨家權利。政府將有權向附近其他地段擁有人於現時或將來任何時間授予棕色範圍的通行權，或接管棕色範圍之全部或任何部分以作公共街道。政府毋須就此向買方或任何獲授棕色範圍之全部或任何部分的通行權之其他擁有人作出任何賠償。」

27. 批地文件特別條件第(27)(g)條規定：

「倘若買方未能履行本特別條件第(b)、(c)及(d)分條的責任，政府可

執行必要工程，費用由買方承擔並在政府通知時支付予政府一筆等同該費用的金額。該金額由署長規定，其決定將作終論並約束買方。」

28. 批地文件特別條件第(27)(h)條規定：

「儘管本特別條件第(a)分條所授予的通行權，政府於向買方發出不少於十四天書面通知後(緊急情況除外)有權利和權力並應署長全權酌情認為適合鋪設、安裝、重鋪、改道、拆除、重置、取代、檢查、操作、修理、維修及更新任何政府或其他於現時或此後在棕色範圍之內、上、下或毗鄰之排水道、下水道、水道或渠道、污水道、明渠、總水喉、水管、電纜、電線、線、公用服務設施或其他工程或裝置(統稱「棕色範圍服務」)，並修復因此引起的任何及所有損害。政府、署長及其人員、承建商及代理及任何署長授權的人士及彼等工人，不論是否備有工具、設備、裝置、機器或汽車，有權時刻暢通無阻地進出、返回及通過棕色範圍，以便進行上述工程。未經署長事先書面許可，買方不得騷擾或允許任何人騷擾棕色範圍服務。除修復因行使上述權利和權力而致的任何及所有損害以外，政府、署長及其官員、承建商及代理及署長授權的任何人士及彼等工人毋須就行使本第(h)分條所載權利而導致或引致買方所蒙受或招致的任何損失、損害、滋擾或騷擾承擔責任。買方亦不可就此等損失、損害、滋擾或騷擾向該等人士索償或提出反對。」

29. 批地文件特別條件第(28)條規定：

「除獲署長事先書面批准外，買方不可分割、移除或移後任何鄰近或毗連該地段的政府土地，或對任何政府土地進行任何形式的建築、填土或任何斜坡處理工程。署長可全權酌情在給予有關批准時訂立其認為適合之條款及條件，包括以其決定的地價溢價批出額外政府土地以擴展該地段。」

30. 批地文件特別條件第(29)(a)條規定：

「倘若任何土地遭分割、移除或移後，或倘若任何建造、填土或任何斜坡處理工程經進行(不論有否獲得署長事先書面同意，亦不論是位於該地段內或任何政府土地內，旨在或有關構建、平整或發展該地段或其任何部分或買方按該等條件須進行的任何其他工程或作任何其他用途)，買方須自費開展和建設將會或當時或其後任何時間可能需要的斜坡處理工程、擋土牆或其他承托、防護、排水或任何其他附屬工程，以承托及確保該地段及任何毗鄰或毗連政府土地或租用土地內土地的安全，及防止和避免其後出現塌方、山泥傾瀉或地陷的情況。買方須在批地文件批地年期期間時刻自費維持該地段、斜坡處理工程、擋土牆或其他承托、防護、排水或任何其他附屬工程於修繕妥當及良好的保養狀況，以達致署長滿意。」

31. 批地文件特別條件第(29)(c)條規定：

「倘若因為任何構建、平整、發展或買方進行其他工程或任何其他原因導致任何時候發生塌方、山泥傾瀉或地陷，不論發生在或來自該地段任何土地或任何毗鄰或毗連政府土地或出租土地，買方須自費進行恢復及修復塌方、山泥傾瀉或地陷，以達致署長滿意，並對上述塌方、山泥傾瀉或地陷造成政府、其代理及承建商承受、遭受或產生的一切費用、收費、損害賠償、要求及索償作出彌償。」

32. 批地文件特別條件第(29)(d)條規定：

「除了批地文件所規定對違反該等條件的任何其他權利或補償外，署長有權發出書面通知要求買方進行、興建及保養上述土地、斜坡處理工程、護土牆或其他承托物、保護物及排水系統或附屬工程或其他工程或復原及修復任何塌方、山泥傾瀉或地陷，及倘若買方不理會或未能在通知指定的時期內執行該通知的要求以達致署長滿意，署長可立即執行與進行任何必要工程，而買方須在政府要求時償還政府因此產生的費用連同任何行政費或專業費用及收費。」

33. 批地文件特別條件第(30)條規定：

「如已裝置預應力地錨，當發展或重新發展該地段或其任何部分時，買方須自費在預應力地錨整個使用壽命期內就其進行定期維持及定期監測，以達致署長滿意。買方須提供予署長其不時行使絕對酌處權要求的關於所有該等監測工作的報告及資料。倘若買方疏忽或未能進行所需的檢查工程，署長可立即進行該等檢查工程，買方須在政府要求時付還該等開支予政府。」

34. 批地文件特別條件第(31)(a)條規定：

「倘若從該地段或從其他受該地段的任何發展所影響的區域有泥

# SUMMARY OF LAND GRANT

## 批地文件的摘要

- 土、廢土、瓦礫、建築廢料或建材(下稱「廢料」)遭侵蝕、流入或傾倒至公共巷徑或道路,或路渠、海灘或海床、污水渠、雨水渠或明渠或其他政府產業(下稱「政府產業」),買方須自費清理廢料並修復對政府產業造成的任何損壞。買方須對該等侵蝕、流入或傾倒對私人產業造成的任何損壞或滋擾所引致的一切訴訟、索償及要求向政府作出彌償。」
35. 批地文件特別條件第(32)條規定:
- 「買方須在任何時候,特別是進行建築、保養、翻新或維修工程(下稱「工程」)期間,採取或促使他人採取一切合理及足夠的謹慎、技巧及預防措施,避免對該地段和棕色範圍或該地段或棕色範圍任何部分之上、上面、下或毗鄰的任何政府擁有或其他現有排水渠、水路或水道、總水喉、道路、行人路、街道設施、污水渠、明渠、管道、電纜、電線、公用事業服務或其他工程或裝置(下稱「服務」)造成任何損壞、干擾或阻塞。買方在進行任何工程之前必須進行或促使他人進行適當的勘測及必要的查詢,確定服務的現在位置及水平,並提交處理任何可能受工程影響的服務的書面建議予署長,供其全面審批,及必須在取得署長對服務及上述建議的書面批准後方能進行工程。買方須自費履行署長於批准上述建議時對服務施加的任何要求,包括承擔任何必要的改道、重鋪或修復的費用。買方須自費全面維修、復原及修復因進行工程而對該地段或其任何部分或棕色範圍或該地段或其任何部分和棕色範圍或任何服務以任何方式造成的任何損壞、干擾或阻塞(除非署長另作選擇,明渠、污水渠、雨水渠或總水喉須由署長負責修復,而買方須在政府要求時向政府支付工程的費用),以達致署長滿意。倘若買方未能於該地段或其任何部分或棕色範圍或該地段或其任何部分和棕色範圍或任何服務進行該等必要的改道、重鋪、維修、復原及修復工程,以達致署長滿意,署長可進行他認為必要的該等改道、重鋪、維修、復原及修復工程,而買方須在政府要求時向政府支付工程的費用。」
36. 批地文件特別條件第(33)(a)條規定:
- 「(i) 買方確認直至本協議的日期該地段有現存由中華電力有限公司(下稱「中電」)鋪設的地下供電裝置(下稱「該裝置」)。  
(ii) 茲毋損批地文件一般條件第5條之概括性,買方將被視為滿意並已接受於本協議的日期該地段就存有該裝置的狀況及條件,而買方不得就該事宜作出或提出任何反對或索償。」
37. 批地文件特別條件第(33)(b)條規定:
- 「(i) 除獲得中電事先書面同意,買方不得在批地文件批地年期期間的任何時候干擾或妨礙或移除或搬遷該裝置或允准或容許該裝置遭受到干擾或妨礙或移除或搬遷。  
(ii) 買方須在任何時候,特別是進行任何於該地段或該地段毗鄰的工程時,採取或促使他人採取一切合理及足夠的謹慎、技巧及預防措施以避免對該裝置造成任何損壞、干擾或阻塞。  
...」
38. 批地文件特別條件第(33)(c)條規定:
- 「買方須允准中電、其承辦商、工人及代理及其他中電授權代表人士,不論是否備有工具、設備、裝置、機器或汽車,有權於所有合理時間暢通無阻地進出、返回及通過該地段或其任何部分,以便檢查、檢驗、翻新和對該裝置進行中電認為必要的工程。」
39. 批地文件特別條件第(34)(a)條規定:
- 「買方需自費建造及維修署長認為必要的水渠及渠道(無論是否位於該地段範圍內或政府土地上),以將所有落在該地段上或在該地段上流動的暴雨水或雨水收集並排去至就近的水道、水井、渠道或政府排水渠,達致署長滿意。買方須就暴雨水或雨水造成任何損害或滋擾所引起的一切訴訟、申索及要求單獨負責及向政府及其人員作出彌償。」
40. 批地文件特別條件第(34)(b)條規定:
- 「該地段任何排水渠及污水管連接至已鋪設並已啟用的政府雨水渠及污水渠之工程可由署長進行,但署長毋須就因此產生的任何損失或損害對買方負責,而買方須在政府要求時向政府支付上述連接工程的費用。或者,該等連接工程亦可由買方自費進行,以達致署長滿意,而在該情況下,若在政府土地內興建上述連接工程任何一段,須由買方自費保養,直至政府要求時由買方移交給政府,由政府出資負責往後的保養,而買方須在政府要求時向政府支付有關上述連接工
- 程的技術檢查之費用。若買方未能保養在政府土地內興建的上述連接工程任何一段,署長可進行其認為必要的保養工程,而買方須在政府要求時向政府支付該等工程費用。」
41. 批地文件特別條件第(35)(a)條規定:
- 「除獲水務署署長事先書面同意外,來自政府總水喉的食水不得用作沖廁用途。」
42. 批地文件特別條件第(35)(b)條規定:
- 「儘管有本特別條件第(a)分條,倘若買方自費安裝海水管道並在將來有海水供應時接受該海水供應,買方可獲水務署署長同意以食水作沖廁用途。」
43. 批地文件特別條件第(35)(c)條規定:
- 「政府不保證將來會有海水供應...」
44. 批地文件特別條件第(36)(a)條規定:
- 「(i) 買方特此明示確認並接受直至本協議的日期,附近沒有供連接至該地段的政府污水渠。  
(ii) 買方須自費於令署長在各方面達致滿意的位置、物料和標準於該地段內興建和提供污水處理工程和棄置設施(下稱「**污水處理工程和棄置設施**」)。買方須在其後自費操作、維修和修理污水處理工程和棄置設施,以達致署長滿意。」
45. 批地文件特別條件第(36)(b)條規定:
- 「當已鋪設和提供於該地段附近政府污水渠,買方須自費和令署長在各方面達致滿意的情況下以令署長在各方面達致滿意的方式、物料和標準於該地段內更改於該地段內的污水渠及/或興建新的污水渠,以連接該污水渠至政府污水渠。」
46. 批地文件特別條件第(36)(c)條規定:
- 「當連接於該地段內的污水渠至本特別條件第(b)分條及批地文件特別條件第(34)條指的政府污水渠的工程完成後,買方須在署長要求時自費拆除及移除污水處理工程和棄置設施,惟該拆除及移除須在署長在各方面達致滿意的情況下進行及完成。」
47. 批地文件特別條件第(36)(e)條規定:
- 「在本特別條件第(c)分條所指的污水處理工程和棄置設施的拆除及移除之前,政府、署長及其人員、承建商及代理及任何署長授權的人士及彼等工人,不論是否備有工具、設備、裝置、機器或汽車,有權時刻暢通無阻地進出、返回及通過該地段或其任何部分,以便檢查、抽樣調查、測試、測量、量度和紀錄污水處理工程和棄置設施...」
48. 批地文件特別條件第(37)(a)條規定:
- 「(i) 買方特此確認直至本協議的日期,有排水渠、污水管、渠道、排水設施及其他服務經過、通過或在批地文件特別條件第(37)(b)(i)條所指的渠務專用範圍下面(以下統稱「**該公用設施**」)。  
(ii) 茲毋損批地文件一般條件第(5)條之概括性,買方將被視為滿意並已接受於本協議的日期該地段就存有該公用設施狀況及條件,而買方不得就該事宜作出或提出任何反對或索償。  
...」
49. 批地文件特別條件第(37)(b)條規定:
- 「(i) 不得在批地文件附錄圖則上以粉紅色間黑斜線顯示及標示為「D.R.」的該地段的部分(下稱「**渠務專用範圍**」)上、上方、之上、下面、之下或之內豎立、興建或放置任何建築物、結構物或任何建築物或結構物的支撐物件,除了在渠務專用範圍上的伸出物,但由地面層或於渠務專用範圍內的層數延伸向上有多於6米的完整空間...」
50. 批地文件特別條件第(37)(c)條規定:
- 「政府、署長及其人員、承建商及代理及任何署長授權的人士及彼等工人,不論是否備有工具、設備、裝置、機器或汽車,在批地文件批地年期期間有權時刻暢通無阻地進出、返回及通過該地段或其任何部分,以便進行署長可能要求或授權的鋪設、檢查、修理、維修、取代及更新該公用設施或其任何部分。渠務專用範圍內不能放置可能會阻

## SUMMARY OF LAND GRANT

### 批地文件的摘要

礙存取該公用設施或造成該公用設施過量附加費的物件或物料，不管該物件或物料的性質。倘若署長認為渠務專用範圍內有物件或物料可能會阻礙存取該公用設施或造成該公用設施過量附加費(該決定為最終的，且對買方具有約束力)，署長可透過書面通知要求買方自費拆除或移除該物件或物料並恢復渠務專用範圍，以在各方面達致署長滿意。倘若買方不理會或未能在該通知指定的或於緊急情況下要求的時限內執行該通知的要求，署長可立即進行按其認為必要的拆除、移除及恢復工程，而買方須在政府要求時償還政府一筆等同該工程費用的金額。該金額由署長規定，其決定將作終論並約束買方。」

51. 批地文件特別條件第(38)(a)條規定：

「買方須於由本協議的日期起計六個曆月內或署長批准的任何延長期內自費提交或促使他人提交排污影響評估(下稱「**排污影響評估**」)予環境保護署署長書面審批，以在各方面達致環境保護署署長滿意。排污影響評估須包含環境保護署署長可能需要的資料及詳情，包括但不限於發展該地段引起的所有不利的排污影響、同一個污水收集區中來自所有其他已計劃和已著手發展的發展項目的污水，以及緩解措施、改善工程及其他措施和工程的建議。」

52. 批地文件特別條件第(38)(b)條規定：

「買方須自費於環境保護署署長指定的限期內實施經審批的排污影響評估內的建議，以在各方面達致環境保護署署長滿意。」

53. 批地文件特別條件第(39)(a)條規定：

「買方須於由本協議的日期起計六個曆月內或署長批准的任何延長期內自費提交或促使他人提交排水影響評估(下稱「**排水影響評估**」)予渠務署署長書面審批，以在各方面達致渠務署署長滿意。排水影響評估須包含渠務署署長可能需要的資料及詳情，包括但不限於發展該地段引起的所有不利的排水影響，以及緩解措施、改善工程及其他措施和工程的建議(以下統稱「**排水緩解措施**」)。」

54. 批地文件特別條件第(39)(b)條規定：

「買方須自費於渠務署署長指定的限期內實施經審批的排水影響評估內的建議，以在各方面達致渠務署署長滿意。」

55. 批地文件特別條件第(39)(d)條規定：

「(i) 茲毋損本特別條件第(b)分條之概括性，如渠務署署長要求，買方須於該地段自費並在渠務署署長指定的限期內提供、興建及豎立一個地下蓄洪池或相似的設施(下稱「**地下蓄洪池**」)，作為排水緩解措施的一部分，並在各方面達致渠務署署長滿意。

(ii) 買方往後須時刻地並自費維修地下蓄洪池，在各方面達致渠務署署長滿意，並確保受排水系統影響的上游和下游地區不會受到不利的排水影響。

...」

56. 批地文件特別條件第(40)(a)條規定：

「茲毋損批地文件一般條件第5條之概括性，買方特此確認該地段是位於海岸的附近，因此該地段因此可能受潮汐及海浪影響。」

57. 批地文件特別條件第(40)(b)條規定：

「買方須自費並在土木工程拓展署署長指定的限期內根據土木工程拓展署出版的海港工程設計手冊及土木工程拓展署署長全權酌情決定施加的任何要求於該地段內設計、豎立、興建及提供海堤及海事結構物，在各方面達致土木工程拓展署署長滿意，以保護該地段免受潮汐及海浪影響。買方往後須時刻地並自費維修海堤及海事結構物，在各方面達致土木工程拓展署署長滿意。就本(b)分條而言，土木工程拓展署署長對何謂會構成海堤及海事結構物之決定為最終的，且對買方具有約束力。」

58. 批地文件特別條件第(40)(c)條規定：

「有關不論是否用於保護或糾正該地段免受因該地段位於海岸的附近或該地段受潮汐及海浪影響而產生的任何損失或損害而進行的任何工程的所有附加費用、收費及開支，買方特此明示確認及接受該附加費用、收費及開支是由買方單獨負責支付，而政府毋須就該附加費用、收費及開支對買方、其繼承人及受讓人負責。」

59. 批地文件特別條件第(40)(d)條規定：

「買方代表自己、其繼承人及受讓人明示放棄向政府作出因該地段位於海岸的附近或該地段受潮汐及海浪影響而引起的所有索償，並解除政府因該地段位於海岸的附近或該地段受潮汐及海浪影響而產生的所有責任...」

60. 批地文件特別條件第(41)(a)條規定：

「買方沒有由該地段到海及由海到該地段的通行權。」

61. 批地文件特別條件第(41)(b)條規定：

「政府保留隨時對該地段前濱至臨海位置進行填海的權利，而買方不會就該填海工程獲得不論是否根據前濱及海床(填海工程)條例、其附屬規例及任何修訂或其他原因下的賠償。」

62. 批地文件特別條件第(44)條規定：

「不得於該地段豎立或建造墳墓或骨灰甕，亦不得於該地段以陶罐、骨灰甕或其他形式安葬或存放任何人類骸骨或動物骸骨。」

註：

1. 如上下文意允許或規定，批地文件所載的「買方」包括其遺產執行人、遺產管理人及受讓人；如屬公司則包括其繼承人及受讓人。

2. 請參閱批地文件以了解全部詳情。完整的批地文件文本可於售樓處營業時間作出要求後免費查閱，並可在支付所需影印費後取得批地文件之複印本。

# INFORMATION ON PUBLIC FACILITIES AND PUBLIC OPEN SPACES

## 公共設施及公眾休憩用地的資料

### A. Facilities that are required under the Land Grant to be constructed and provided for the Government, or for public use

#### 1. Brown Area as referred to in Special Condition No.(27) of the Land Grant

##### (1) Relevant provisions of the Land Grant that concern the above facilities:

Special Condition No.(27) of the Land Grant stipulates that: -

"(a) The lot is granted together with a right for the Purchaser and his servants, visitors, workmen and other persons authorized by the Purchaser in that behalf from time to time and at all times during the term hereby agreed to be granted for all purposes connected with the proper use and enjoyment of the lot to pass and repass, on, along, over, by and through the area shown coloured brown on the plan annexed hereto (hereinafter referred to as "the Brown Area") at such levels as may be approved by the Director.

(b) The Purchaser shall within 54 calendar months from the date of this Agreement (or within such other extended period as may be approved by the Director), at his own expense, in such manner, with such materials and to such standards as the Director shall require or approve, construct a paved way with the associated street furniture, traffic aids, street lighting, sewers, drains and other structures on the Brown Area over and along which a right of way referred to in sub-clause (a) of this Special Condition is given with minimum disturbance to the owners of any other lots in the vicinity to whom rights of way over the whole or any portion of the Brown Area may be have been granted.

(c) (i) The Purchaser shall within 24 calendar months from the date of this Agreement (or such other extended period as may be approved by the Director), at his own expense and in all respects to the satisfaction of the Director submit or cause to be submitted to the Director for his approval in writing a slope stability assessment (hereinafter referred to as "SSA") containing, among others, such information and particulars as the Director may require including but not limited to the slope stability assessment of the Brown Area and the area adjacent thereto and recommendations for mitigation measures, improvement works and other measures and works.

(c) (ii) The Purchaser shall within 54 calendar months from the date of this Agreement (or such other extended period as may be approved by the Director), at his own expense implement the recommendations in the approved SSA in all respects to the satisfaction of the Director.

(c) (iii) For the avoidance of doubt and without prejudice to the generality of General Condition No.5 hereof, the Purchaser hereby expressly acknowledges and agrees that he shall have the sole responsibility at his own expense to implement the recommendations in the approved SSA in all respects to the satisfaction of the Director. The Government and its officers shall be under no responsibility, obligation or liability whatsoever to the Purchaser for any cost, damage or loss caused to or suffered by the Purchaser whether arising out of or incidental to the fulfilment of the Purchaser's obligations under this Special Condition or otherwise, and no claim whatsoever shall be made against the Government or its officers by the Purchaser in respect of any such cost, damage or loss.

(d) The Purchaser shall at his own expense uphold, maintain and repair the Brown Area and everything forming a portion of or pertaining to it, all to be done to the satisfaction of the Director, and the Purchaser shall be responsible for the whole as if he were the absolute owner thereof.

(e) Any alternation to any public road absorbing a portion of the Brown Area over and along which a right of way is given or affecting the gradient thereof shall not give rise to any claim whatsoever by the Purchaser who shall at his own expense carry out all consequent alterations to the paved way constructed by him to the satisfaction of the Director.

(f) The grant of the right of way referred to in sub-clause (a) of this Special Condition shall not give the Purchaser the exclusive right over the Brown Area. The Government shall have the right to grant rights of way over the Brown Area to the owners of any other lots in the vicinity now or at any time in the future, or to take over the whole or any portion of the Brown Area for the purposes of a public street without payment of any compensation to the Purchaser or to other owners to whom rights of way over the whole or any portion of the Brown Area may have been granted.

(g) In the event of the non-fulfilment of the Purchaser's obligations under sub-clauses (b), (c) and (d) of this Special Condition, the Government may carry out the necessary works at the cost of the Purchaser who shall pay to the Government on demand a sum equal to the cost thereof, such sum to be determined by the Director whose determination shall be final and binding upon the Purchaser.

(h) Notwithstanding the grant of the right of way referred to in sub-clause (a) of this Special Condition, the Government shall have the full right and power, upon giving to the Purchaser not less than fourteen days' written notice (save in case of emergency) to lay, install, relay, divert, remove, reprovision, replace, inspect, operate, repair, maintain and renew any Government or other drain, culvert, waterway or watercourse, sewer, nullah, water main, pipe, cable, wire, line, utility service or other works or installations (all together hereinafter referred to as "the Brown Area Services") which are now or may hereafter be upon, over, under or adjacent to the Brown Area as the Director may in his absolute discretion deem fit, making good any and all damage caused thereby, and the Government, the Director and his officers, contractors and agents and any persons authorized by the Director, his or their workmen with or without tools, equipment, plant, machinery or motor vehicles shall have the right of free and unrestricted ingress, egress and regress at all times to, from and through the Brown Area for the purposes aforesaid. The Purchaser shall not disturb or allow anybody to disturb the Brown Area Services without the prior written approval from the Director. Save in respect of making good any and all damage caused by any exercise of the aforesaid rights and powers, the Government, the Director and his officers, contractors and agents and any persons authorized by the Director, his or their workmen shall have no liability in respect of any loss, damage, nuisance or disturbance whatsoever caused to or suffered by the Purchaser arising out of or incidental to the exercise of the rights conferred under this sub-clause (h), and no claim nor objection whatsoever shall be made against him or them by the Purchaser."

##### (2) Relevant provisions of the Deed of Mutual Covenant that concern the above facilities:

Clause 1.1 stipulates that:-

" "Right of Way Area" means the areas shown coloured Brown on the plan annexed to the Government Grant which areas is required to be upheld, maintained and repaired in accordance with Special Condition No.(27) of the Government Grant."

Clauses 3.1.1 (a) stipulates that:-

"The Owner of a House shall have the benefit of the following easements, rights and privileges subject to the provisions in this Deed including the provisions of the rights of the Manager as herein provided :-

(a) full right and liberty for each Owner of a House, his tenants, servants, agents and licensees to go pass and repass over and along and use the Estate Common Areas and the Estate Common Facilities and (in common with all persons having the like right and subject to the rights of the general public in respect of the Right of Way Area) to go pass and repass the Right of Way Area for all purposes connected with the proper use and enjoyment of his House..."

Clauses 6.2.1 (39) and (55) stipulate that:-

"During the term of its appointment as the Manager, the Manager shall, subject to the provisions of the Ordinance and subject also to Clauses 6.1.1 and 6.1.2, manage the Land and the Estate in a proper manner and in accordance with the provisions of this Deed and each Owner hereby appoints the Manager as agent for all Owners in respect of any matters concerning the Estate Common Areas and the Estate Common Facilities duly authorized in accordance with the provisions of this Deed with full power to enforce the provisions of this Deed against the other Owners. Subject to the provisions of the Ordinance, the Manager shall have the authority to do all such acts and things as may be necessary or expedient for the management of the Estate for and on behalf of all Owners in accordance with the provisions of this Deed and each Owner irrevocably appoints the Manager as agent in respect of any matter concerning the Estate Common Areas and Estate Common Facilities and all other matters duly authorized under this Deed Provided that the Manager shall not effect any improvements to facilities or services which involves expenditure in excess of 10% of the current annual management budget except with the prior approval by resolution of the Owners passed at an Owners' meeting convened under this Deed. Without in any way limiting the generality of the foregoing the Manager shall have the following duties :-

...

# INFORMATION ON PUBLIC FACILITIES AND PUBLIC OPEN SPACES

## 公共設施及公眾休憩用地的資料

(39) To act as agent for and on behalf of all Owners in respect of all matters concerning the Estate Common Areas or the Estate Common Facilities or the Right of Way Area duly authorized in accordance with the provisions of this Deed and the Government Grant and the Manager is hereby authorized to act as such agent.

(55) To maintain, repair, reinstate and make good the Right of Way Area pursuant to and subject to the provisions of the Government Grant.”

Clauses 6.4.1 (b) and (x) stipulate that:-

“The Owners of the Estate shall pay to the Manager monthly in advance in the manner hereinafter provided the Management Expenses which shall be made up of the following :-

...

(b) The cost of purchasing or hiring all necessary plant, equipment and machinery in connection with the management and maintenance of the Land and the Estate and the Right of Way other than the Houses.

...

(x) The expenses for the operation, maintenance, repair and reinstatement of and making good the Right of Way Area, the Salt Water Plumbing Facilities, the Existing Sewerage Treatment Facilities and the New Sewers.”

### B. Facilities that are required under the Land Grant to be managed, operated or maintained for public use at the expense of the owners of the residential properties in the Development

1. Brown Area as referred to in Special Condition No.(27) of the Land Grant  
Please refer to paragraph A above.

### C. Size of any open space that is required under the Land Grant to be managed, operated or maintained for public use at the expense of the owners of the residential properties in the Development

Not Applicable.

### D. Any part of the land (on which the Development is situated) that is dedicated to the public for the purposes of regulation 22(1) of the Building (Planning) Regulations (Cap.123 Sub. Leg. F)

Not Applicable.

In relation to any of those facilities and open spaces, and those parts of the land, mentioned in paragraphs A, B, C and D above that are for public use, the general public has the right to use the facilities or open spaces, or the parts of the land, in accordance with the land grant or the deed of dedication (as the case may be). In relation to any of those facilities and open spaces mentioned in paragraphs B or C above, the facilities or open spaces are required to be managed, operated or maintained at the expense of the owners of the residential properties of the Development, and those owners are required to meet a proportion of the expense of managing, operating or maintaining the facilities or open spaces through the management expenses apportioned to the residential properties concerned.

Notes:

1. The expression as mentioned in this section “Director” means “the Director of Lands”, unless otherwise specified.
2. The expression “Purchaser” as mentioned in this section means the “Purchaser” under the Land Grant and under Summary of Land Grant, and where the context so admits or requires includes his executors, administrators and assigns and in case of a corporation its successors and assigns.

### A. 根據批地文件規定須興建並提供予政府或供公眾使用的設施

#### 1. 批地文件特別條件第(27)條所指的「棕色範圍」

##### (1) 批地文件相關條文

批地文件特別條件第(27)條規定：

「(a) 買方與其受傭人、訪客、工人及其他買方授權代表人士可於批地年期內不時及時刻為着達致完善使用及享用該地段的所有一切事宜在署長批准之水平進出、往返及經越於批地文件附錄圖則上以棕色顯示的範圍（下稱「棕色範圍」）。

(b) 買方須於本協議的日期起計54個曆月內，或署長可批准的其他延長期限內，根據署長要求或批准的標準、物料及方式在本特別條件第(a)分條下給予通行權的棕色範圍自費興建鋪築路面道路及相關的街道設施、交通輔助設施、街燈、污水管、排水渠及其他結構物，並對附近可能已獲得全部或部分棕色範圍通行權之其他土地擁有人造成最少干擾。

(c) (i) 買方須於本協議的日期起計24個曆月內，或署長可批准的其他延長期限內，自費提交或促使他人提交斜坡穩定性評估（下稱「斜坡穩定性評估」）予署長書面審批，以在各方面達致署長滿意。斜坡穩定性評估須包含署長可能需要的資料及詳情，包括但不限於棕色範圍及鄰近地方的斜坡穩定性評估，以及緩解措施、改善工程及其他措施和工程的建議。

(c) (ii) 買方須於本協議的日期起計54個曆月內，或署長可批准的其他延長期限內，自費實施經審批的斜坡穩定性評估內的建議，以在各方面達致署長滿意。

(c) (iii) 為免存疑和在毋損批地文件一般條件第5條概括性的情況下，買方特此明示確認及同意他須獨自負責自費實施經審批的斜坡穩定性評估內的建議，以在各方面達致署長滿意。政府及其人員對買方因履行本特別條件或其他條款的責任所引起或附帶所引起的任何費用、損害或損失毋須承擔任何責任或義務。買方亦無權就上述費用、損害或損失向政府或其人員作出索償。

(d) 買方須自費保養、維修及修理棕色範圍及所有附屬該處和與該處有關的物件，以達致署長滿意。買方將對該處全部負責，猶如該處的絕對擁有人一樣。

(e) 對於公路更改工程所導致覆蓋部分買方獲授通行權的棕色範圍或影響該處之坡度，買方不得就此提出索償。買方須自費進行由其興建的鋪築路面道路的其後更改工程，以達致署長滿意。

(f) 根據本特別條件第(a)分條所授予的通行權並不向買方授予棕色範圍的獨家權利。政府將有權向附近其他地段擁有人於現時或將來任何時間授予棕色範圍的通行權，或接管棕色範圍之全部或任何部分以作公共街道。政府毋須就此向買方或任何獲授棕色範圍之全部或任何部分的通行權之其他擁有人作出任何賠償。

(g) 倘若買方未能履行本特別條件第(b)，(c)及(d)分條的責任，政府可執行必要工程，費用由買方承擔並在政府通知時支付予政府一筆等同該費用的金額。該金額由署長規定，其決定將作終論並約束買方。

# INFORMATION ON PUBLIC FACILITIES AND PUBLIC OPEN SPACES

## 公共設施及公眾休憩用地的資料

(h) 儘管本特別條件第(a)分條所授予的通行權，政府於向買方發出不少於十四天書面通知後（緊急情況除外）有權利和權力並應署長全權酌情認為適合鋪設、安裝、重鋪、改道、拆除、重置、取代、檢查、操作、修理、維修及更新任何政府或其他於現時或此後在棕色範圍之內、上、下或毗鄰之排水道、下水道、水道或渠道、污水道、明渠、總水喉、水管、電纜、電線、線、公用服務設施或其他工程或裝置（統稱「棕色範圍服務」），並修復因此引起的任何及所有損害。政府、署長及其人員、承建商及代理及任何署長授權的人士及彼等工人，不論是否備有工具、設備、裝置、機器或汽車，有權時刻暢通無阻地進出、返回及通過棕色範圍，以便進行上述工程。未經署長事先書面許可，買方不得騷擾或允許任何人騷擾棕色範圍服務。除修復因行使上述權利和權力而致的任何及所有損害以外，政府、署長及其官員、承辦商及代理及署長授權的任何人士及彼等工人毋須就行使本第(h)分條所載權利而導致或引致買方所蒙受或招致的任何損失、損害、滋擾或騷擾承擔責任。買方亦不可就此等損失、損害、滋擾或騷擾向該等人士索償或提出反對。」

### (2) 公契相關條文

第1.1條規定：

「通行權範圍」 該批地文件附錄圖則上以棕色顯示的範圍，須按該批地文件特別條件第(27)條進行保養、維修及修理。」

第3.1.1(a)條規定：

「受限於本公契的條文(包括本公契提及有關管理人之權利之條文)，洋房業主將享有以下通行權、權利及特權:-

(a) 各洋房擁有人、其租客、工人、代理及被許可人的全部權利和自由，可進出和越過並使用屋苑公用地方及屋苑公用設施，及（與擁有相同權利的所有人共同享有及受限於公眾就通行權範圍所享有之權利）出於與正確使用和享用其洋房有關的所有目的而進出通行權範圍...」

第6.2.1(39)及(55)條規定：

「在管理人獲委任期間，受限於該條例的條文及受限於第6.1.1條及第6.1.2條，管理人須以適合的方式依據本公契的條文管理該土地及該屋苑，及各業主現特此委任管理人為所有業主的代理，以根據本公契的條文獲正式授權處理任何關於屋苑公用地方及屋苑公用設施的事宜，並賦有全權對其他業主執行本公契的條文。受限於該條例的條文，管理人按本公契的條文獲授權代表全部業主就管理該屋苑作必要及有利的行動及事情，而各業主現不可撤回地委任管理人為代理以處理任何關於屋苑公用地方及屋苑公用設施的事宜及所有其他根據本公契獲正式授權的事宜。惟管理人不得就任何設施或服務實行支出超出現時年度管理預算的10%的改善工程，除獲得按本公契召開的業主大會決議時通過的事前批准外。在任何方面毋損上述的一般性，管理人有下列職責：

...

(39)根據本公契及批地文件就一切有關屋苑公用地方或屋苑公用設施或通行權範圍作為所有業主的獲授權代表。

(55)根據及受限於批地文件的條文維修、修理、恢復及修復通行權範圍。」

第6.4.1(b)及(x)條規定：

「屋苑業主須以下文規定的方式每月預先繳付管理費用，費用由以下事項組成：

...

(b) 購買或租賃對管理及維修該土地及該屋苑及通行權範圍(洋房除外) 所有必要的裝置、設備及機器的費用。

...

(x) 用於操作、維修、修理及恢復及修復通行權範圍、海水管道設施、現有污水處理設施及新污水渠的費用。」

B. 根據批地文件規定須由發展項目中的住宅物業的擁有人出資管理、營運或維持以供公眾使用的任何設施

#### 1. 批地文件特別條件第(27)條所指的「棕色範圍」

請參閱以上第A段。

C. 根據批地文件規定須由該項目中的住宅物業的擁有人出資管理、營運或維持以供公眾使用的任何休憩用地的尺寸

不適用。

D. 發展項目所位於的土地中為施行《建築物（規劃）規例》(第123章，附屬法例F)第22(1)條而撥供公眾用途的任何部分

不適用。

就以上第A、B、C及D段提述的供公眾使用的任何該等設施及休憩用地，及土地中的該等部分，公眾有權按照批地文件或撥出私人地方供公眾使用的契據（視屬何情況而定）使用該等設施或休憩用地，或土地中的該等部分。就以上第B或C段提述的任何該等設施及休憩用地，按規定須由發展項目中的住宅物業的擁有人出資管理、營運或維持，及該等擁有人按規定須以由有關住宅物業分攤的管理開支，應付管理、營運或維持該等設施或休憩用地的部分開支。

備註：

1. 除非另有指明，本節所載的「署長」一詞所指的是「地政總署署長」。
2. 本節所載的「買方」指批地文件及批地文件的摘要訂明的「買方」，如上下文意允許或規定則包括其遺產執行人、遺產管理人及受讓人；如屬公司則包括其繼承人及受讓人。

# INFORMATION ON PUBLIC FACILITIES AND PUBLIC OPEN SPACES 公共設施及公眾休憩用地的資料



- Pink Hatched Black  
粉紅色間黑斜線
- Pink Stippled Black  
粉紅色加黑點
- Brown  
棕色
- D.R.** Drainage Reserve  
渠務專用

SCALE 0 20 40 60 80 100M/米  
比例 0 20 40 60 80 100M/米

**Note:**

1. The plan is an extract of plan annexed to the Land Grant, with adjustments where necessary, which shows the location of the relevant public facilities.
2. The plan(s) is/are for showing the location of the "Brown Area" only. Other matters shown in the plan(s) may not reflect their latest conditions.

**備註:**

1. 本圖乃摘錄於批地文件夾附的圖則。有需要處經修正處理，以顯示相關公共設施的位置。
2. 本圖僅作顯示「棕色範圍」的位置。圖中所示之其他事項未必能反映其最新狀況。

## WARNING TO PURCHASERS 對買方的警告

---

- a) The purchaser is hereby recommended to instruct a separate firm of solicitors (other than that acting for the owner) to act for the purchaser in relation to the transaction.
  - b) If the purchaser instructs such separate firm of solicitors to act for the purchaser in relation to the transaction, that firm will be able to give independent advice to the purchaser.
  - c) If the purchaser instructs the firm of solicitors acting for the owner to act for the purchaser as well, and a conflict of interest arises between the owner and the purchaser:
    - (i) that firm may not be able to protect the purchaser's interests; and
    - (ii) the purchaser may have to instruct a separate firm of solicitors.
  - d) In the case of paragraph (c)(ii) above, the total solicitors' fees payable by the purchaser may be higher than the fees that would have been payable if the purchaser had instructed a separate firm of solicitors in the first place.
- a) 謹此建議買方聘用一間獨立的律師事務所（代表擁有人行事者除外），以在交易中代表買方行事。
  - b) 如買方聘用上述的獨立的律師事務所，以在交易中代表買方行事，該律師事務所將會能夠向買方提供獨立意見。
  - c) 如買方聘用代表擁有人行事的律師事務所同時代表買方行事，而擁有人與買方之間出現利益衝突：
    - (i) 該律師事務所可能不能夠保障買方的利益；及
    - (ii) 買方可能要聘用一間獨立的律師事務所。
  - d) 如屬上述 (c)(ii) 段的情況，買方須支付的律師費用總數，可能高於如買方自一開始即聘用一間獨立的律師事務所便須支付的費用。

# CROSS-SECTION PLAN OF BUILDING IN THE DEVELOPMENT

## 發展項目中的建築物的橫截面圖

### HOUSE 1 1號洋房

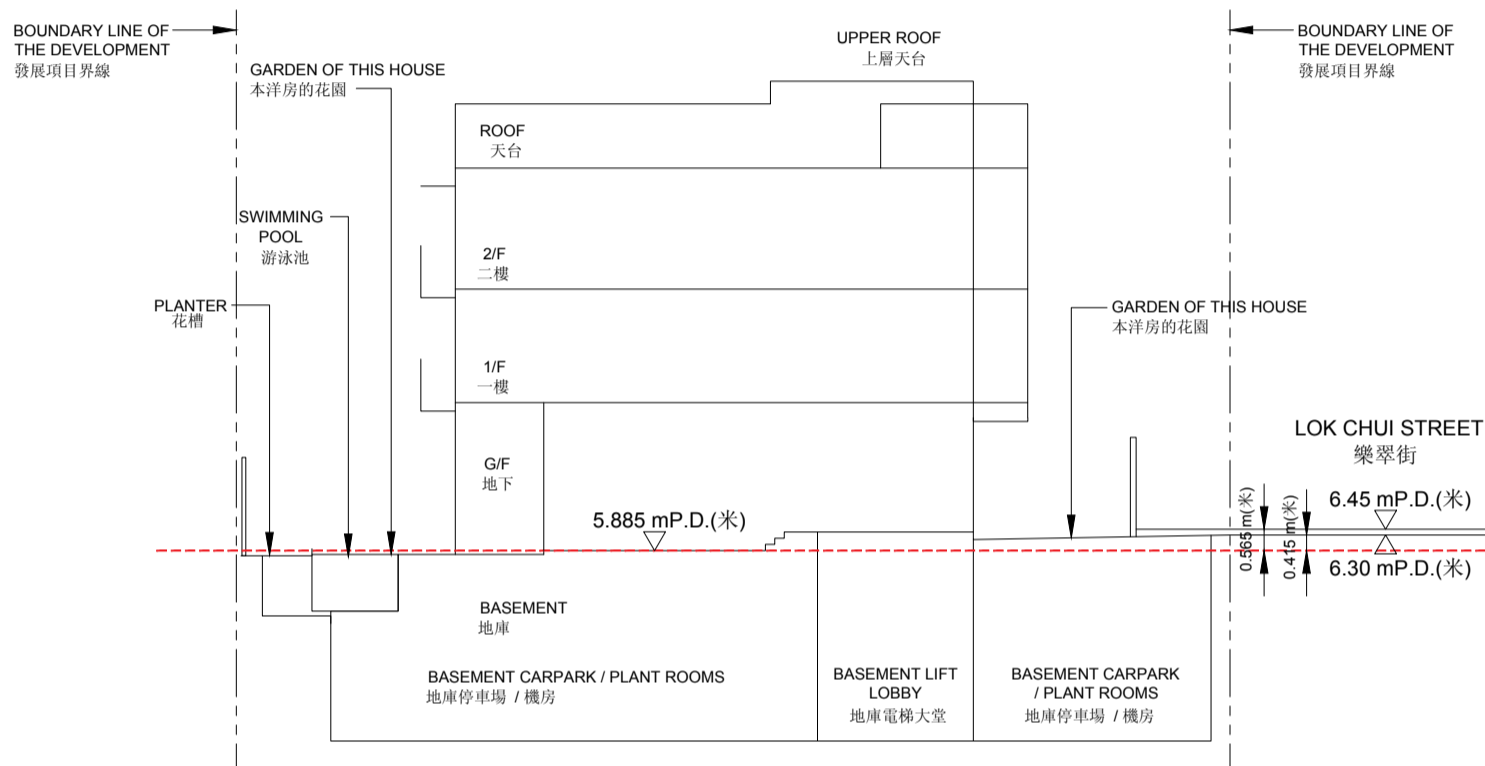
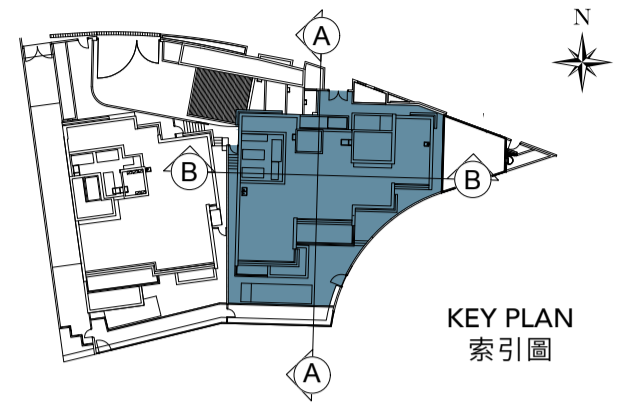

CROSS-SECTION PLAN A-A  
橫截面圖A-A

- The part of Lok Chui Street adjacent to the building is 6.30 to 6.45 metres above the Hong Kong Principal Datum.
- Red dotted line denotes the level of the lowest residential floor.

- 毗連建築物的一段樂翠街為香港主水平基準以上6.30至6.45米。
- 紅色虛線為最低住宅樓層水平。

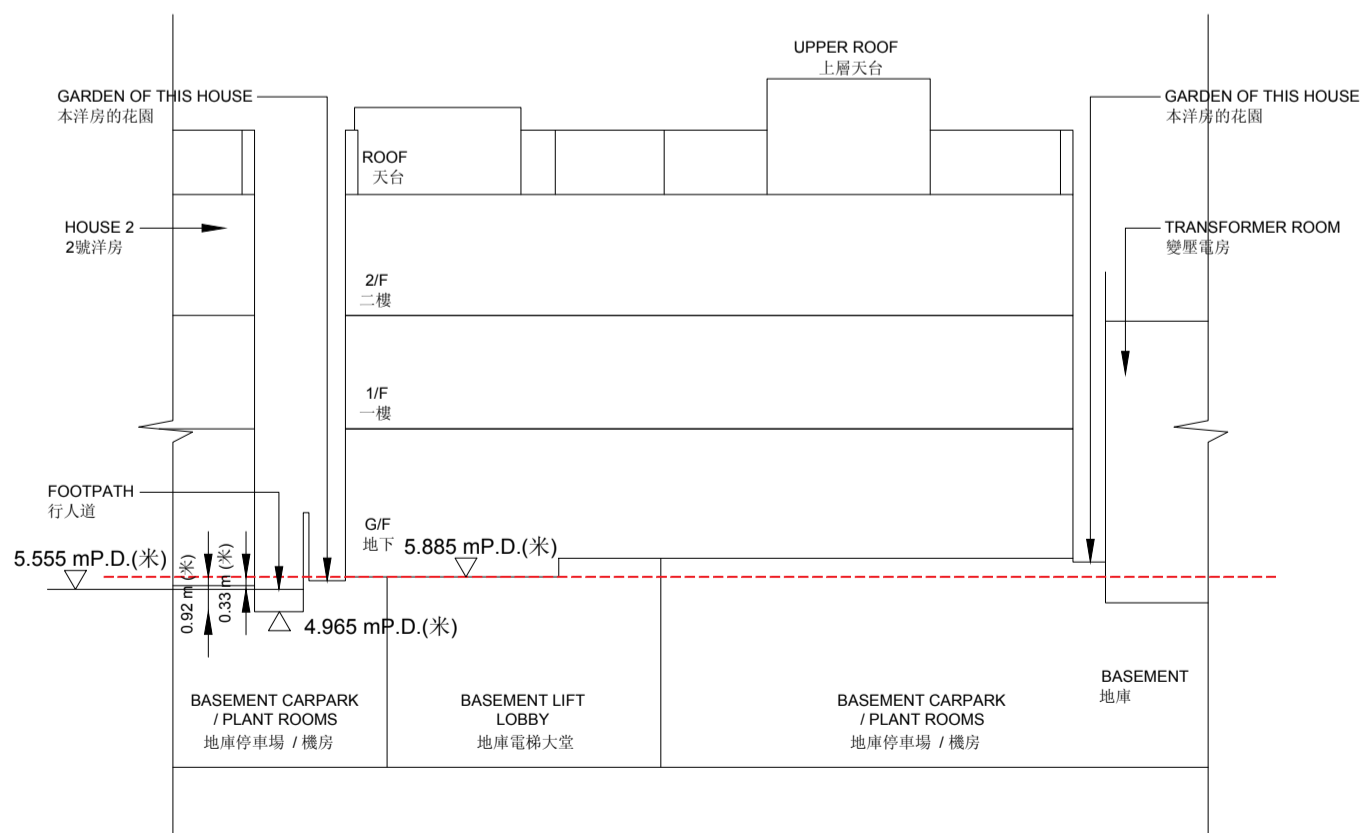

CROSS-SECTION PLAN B-B  
橫截面圖B-B

- The part of footpath adjacent to the building is 4.965 to 5.555 metres above the Hong Kong Principal Datum.
- Red dotted line denotes the level of the lowest residential floor.

- 毗連建築物的一段行人道為香港主水平基準以上4.965至5.555米。
- 紅色虛線為最低住宅樓層水平。

# CROSS-SECTION PLAN OF BUILDING IN THE DEVELOPMENT 發展項目中的建築物的橫截面圖

## HOUSE 2 2號洋房

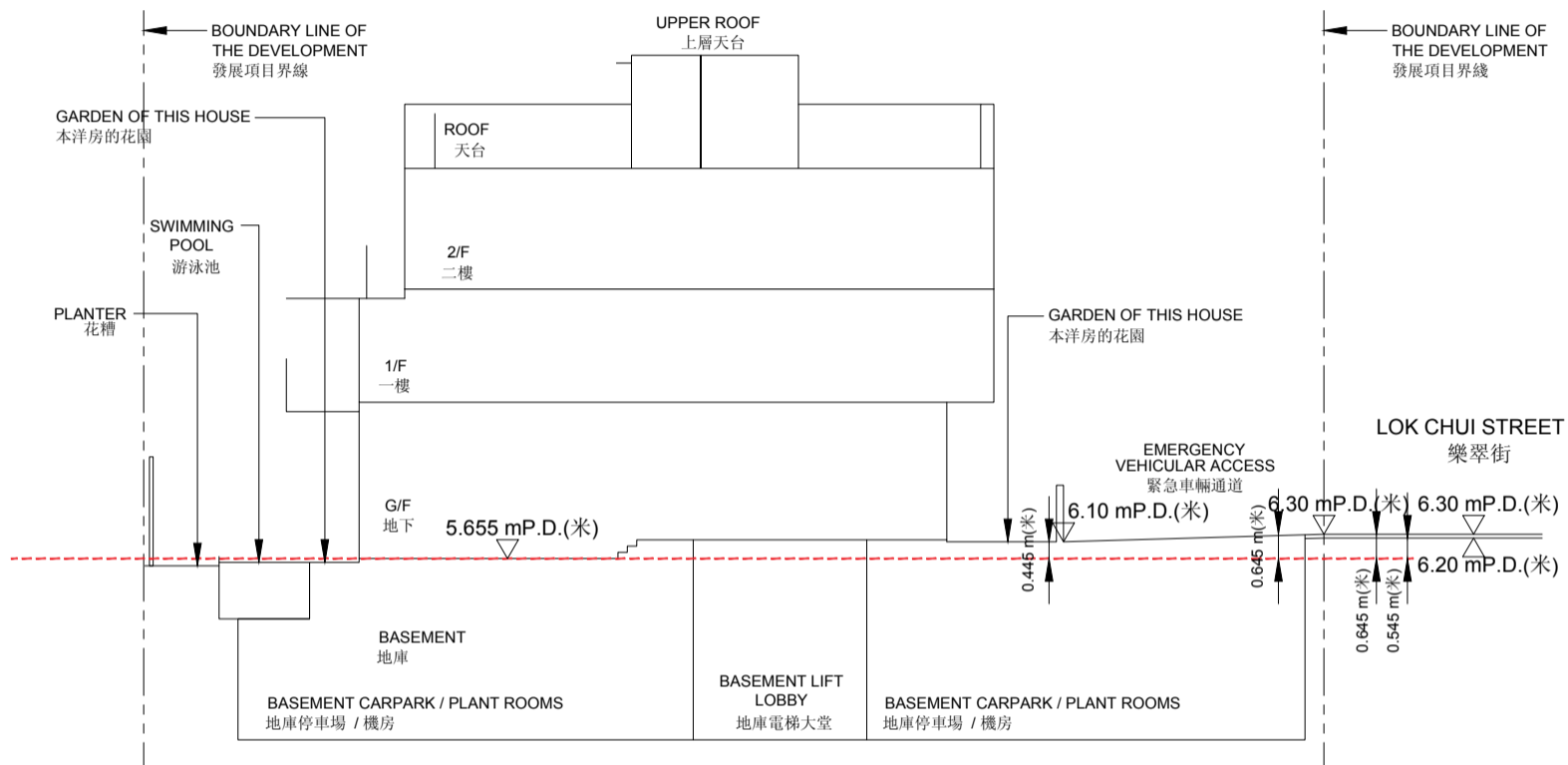
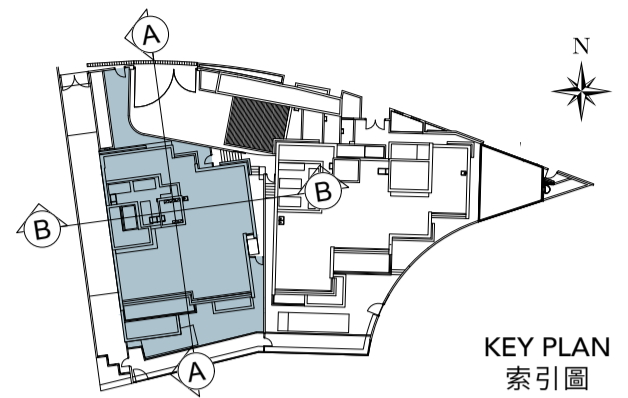

CROSS-SECTION PLAN A-A  
橫截面圖A-A

- The part of emergency vehicular access adjacent to the building is 6.10 to 6.30 metres above the Hong Kong Principal Datum.
- The part of Lok Chui Street adjacent to the building is 6.20 to 6.30 metres above the Hong Kong Principal Datum.
- Red dotted line denotes the level of the lowest residential floor.

- 毗連建築物的一段緊急車輛通道為香港主水平基準以上6.10至6.30米。
- 毗連建築物的一段樂翠街為香港主水平基準以上6.20至6.30米。
- 紅色虛線為最低住宅樓層水平。

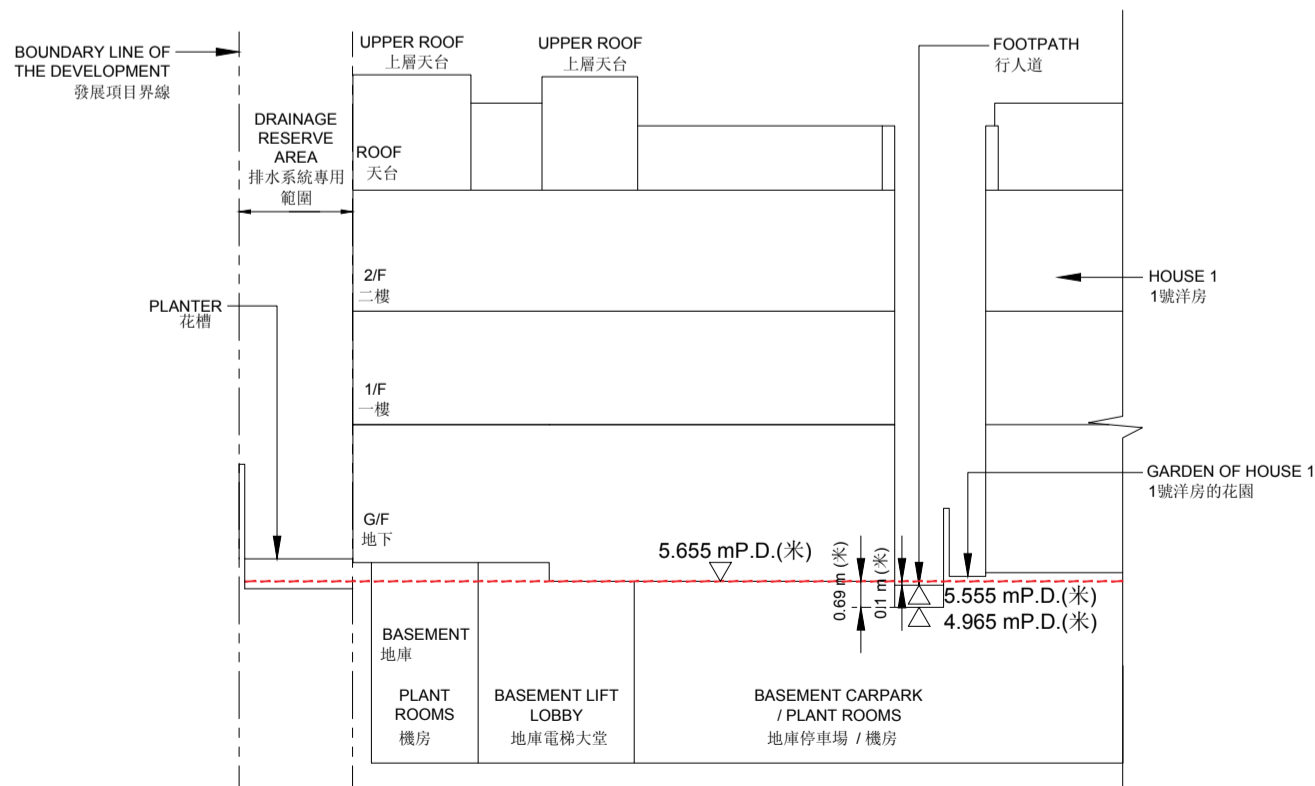

CROSS-SECTION PLAN B-B  
橫截面圖B-B

- The part of footpath adjacent to the building is 4.965 to 5.555 metres above the Hong Kong Principal Datum.
- Red dotted line denotes the level of the lowest residential floor.

- 毗連建築物的一段行人道為香港主水平基準以上4.965至5.555米。
- 紅色虛線為最低住宅樓層水平。

# ELEVATION PLAN 立面圖

## HOUSE 1 1號洋房

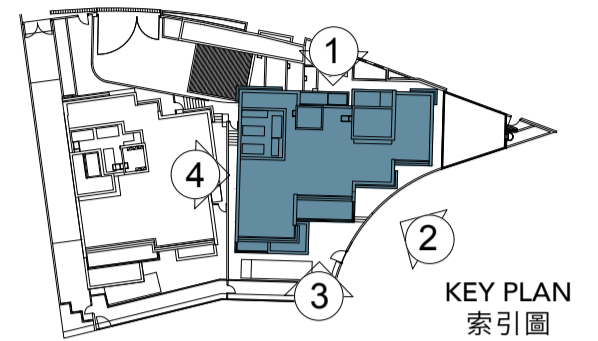

KEY PLAN  
索引圖



ELEVATION 1 (NORTH)  
立面圖1 (北面)



ELEVATION 2 (EAST)  
立面圖2 (東面)

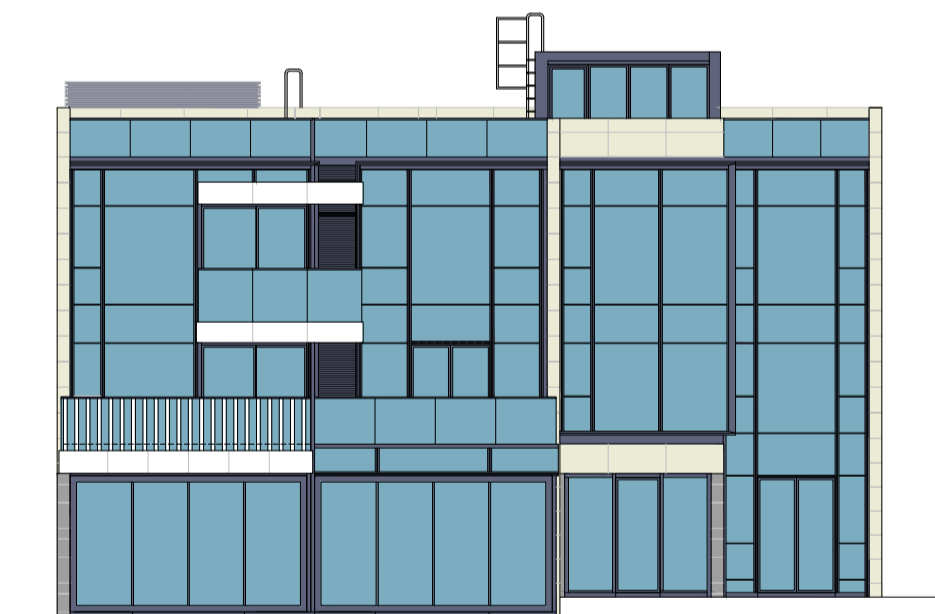

ELEVATION 3 (SOUTH)  
立面圖3 (南面)



ELEVATION 4 (WEST)  
立面圖4 (西面)

Authorized person for the development certified that the elevations shown on this plans:

1. are prepared on the basis of the approved building plans for the development as of 24 January 2020; and
2. are in general accordance with the outward appearance of the development.

發展項目的認可人士證明本圖顯示的立面：

1. 以2020年1月24日的情況為準的發展項目的經批准的建築圖則為基礎擬備；及
2. 大致上與該發展項目的外觀一致。

# ELEVATION PLAN 立面圖

## HOUSE 2 2號洋房

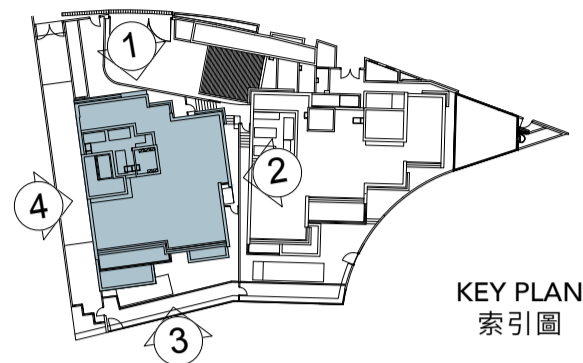

KEY PLAN  
索引圖



ELEVATION 1 (NORTH)  
立面圖1 (北面)

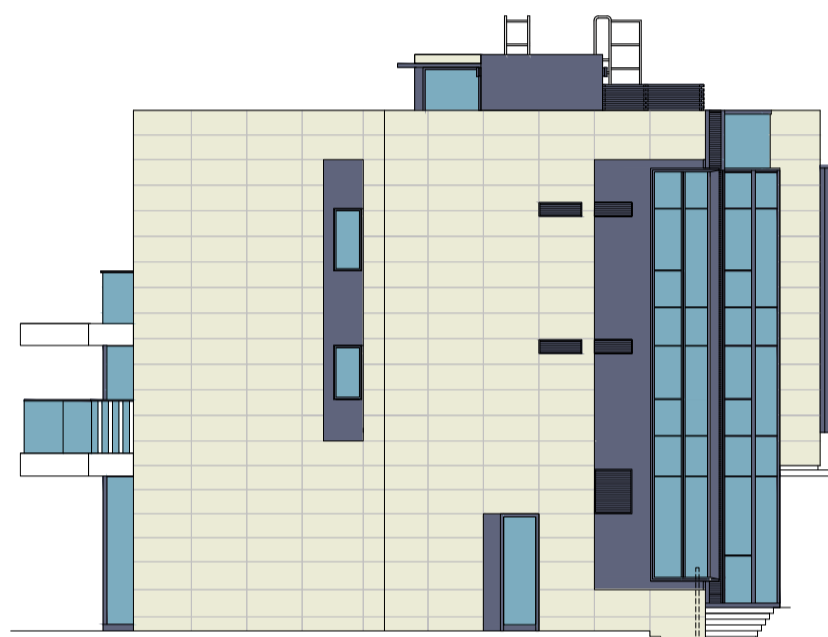

ELEVATION 2 (EAST)  
立面圖2 (東面)

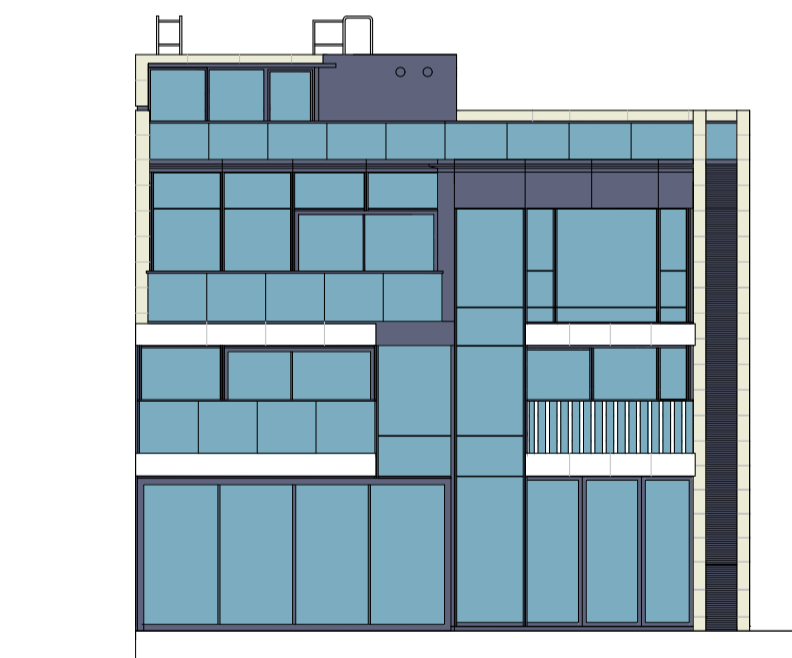

ELEVATION 3 (SOUTH)  
立面圖3 (南面)



ELEVATION 4 (WEST)  
立面圖4 (西面)

Authorized person for the development certified that the elevations shown on this plans:

1. are prepared on the basis of the approved building plans for the development as of 24 January 2020; and
2. are in general accordance with the outward appearance of the development.

發展項目的認可人士證明本圖顯示的立面：

1. 以2020年1月24日的情況為準的發展項目的經批准的建築圖則為基礎擬備；及
2. 大致上與該發展項目的外觀一致。

## INFORMATION ON COMMON FACILITIES IN THE DEVELOPMENT 發展項目中的公用設施的資料

Category of Common Facilities 公用設施的類別		Area 面積		Total Area 總面積	
		sq. m. 平方米	sq. ft. 平方呎	sq. m. 平方米	sq. ft. 平方呎
Residents' Clubhouse (including any recreational facilities for residents' use) 住客會所 (包括供住客使用的任何康樂設施)	Covered 有蓋	Not applicable 不適用	Not applicable 不適用	Not applicable 不適用	Not applicable 不適用
	Uncovered 無蓋	Not applicable 不適用	Not applicable 不適用		
Communal garden or play area for residents' use on the roof, or on any floor between the roof and the lowest residential floor, of a building in the Development (whether known as a communal sky garden or otherwise) 位於發展項目中的建築物的天台或在天台和最低一層住宅樓層之間的任何一層的、供住客使用的公用花園或遊樂地方 (不論是稱為公用空中花園或其他名稱)	Covered 有蓋	Not applicable 不適用	Not applicable 不適用	Not applicable 不適用	Not applicable 不適用
	Uncovered 無蓋	Not applicable 不適用	Not applicable 不適用		
Communal garden or play area for residents' use below the lowest residential floor of a building in the Development (whether known as a covered and landscaped play area or otherwise) 位於發展項目中的建築物的最低一層住宅樓層以下的、供住客使用的公用花園或遊樂地方 (不論是稱為有蓋及園景的遊樂場或有其他名稱)	Covered 有蓋	8.292	89.255	225.377	2425.958
	Uncovered 無蓋	217.085	2336.703		

**Notes:**

1. Areas in square metres as specified above are based on the latest approved building plans.
2. The areas in square metre have been converted to square feet based on a conversion rate of 1 square metre = 10.764 square feet and rounded off to the nearest integer.

**備註:**

1. 上述所列以平方米顯示之面積乃依據最近的經批准的建築圖則。
2. 以平方呎顯示之面積以1平方米=10.764平方呎換算，並四捨五入至整數。

## INSPECTION OF PLANS AND DEED OF MUTUAL COVENANT 閱覽圖則及公契

---

1. A copy of the Outline Zoning Plans relating to development is available at: <http://www.ozp.tpb.gov.hk>
2. (a) A copy of every deed of mutual covenant in respect of the specified residential properties that has been executed is available for inspection at the place at which the residential property is offered to be sold.  
  
(b) The inspection is free of charge.

1. 備有關乎本發展項目的分區計劃大綱圖的文本供閱覽的互聯網網站的網址為：<http://www.ozp.tpb.gov.hk>
2. (a) 指明住宅物業每一已簽立的公契的文本存放在發售住宅物業的地方，以供閱覽。  
  
(b) 無須為閱覽付費。

# FITTINGS, FINISHES AND APPLIANCES

## 裝置、裝修物料及設備

### 1. Exterior Finishes 外部裝修物料

House 1 and House 2

Item	Description
(a) External Wall	External walls of the houses - Finished with curtain wall, aluminum cladding, natural stone cladding, aluminum grille and aluminum louvre.
(b) Window	Window frames are made of fluorocarbon coated aluminum frame with Insulated Glazing Unit (IGU) with low-e coating glass.
(c) Bay Window	Not Applicable
(d) Planter	Not Applicable
(e) Verandah or Balcony	Balcony - Balcony is covered by aluminum cladding ceiling and finished with glass balustrade with aluminum top rail. - Floors are finished with tiles and artificial wooden deck. - All balconies are covered.  - There is no verandah for all houses.
(f) Drying Facilities for Clothing	Not Applicable

1 號洋房及 2 號洋房

細項	描述
(a) 外牆	洋房外牆 - 鋪砌玻璃幕牆、鋁飾板、天然石飾板、鋁格柵及鋁百葉。
(b) 窗	窗框由氟碳噴塗鋁質製成，雙層中空玻璃配低輻射鍍膜。
(c) 窗台	不適用
(d) 花槽	不適用
(e) 陽台或露台	露台 - 露台有鋁飾板天花並裝設玻璃圍欄及鋁質頂欄。 - 地板鋪砌磁磚及人造木平台。 - 全部露台均有蓋。  - 所有洋房沒有陽台。
(f) 乾衣設施	不適用

## FITTINGS, FINISHES AND APPLIANCES 裝置、裝修物料及設備

### 2. Interior Finishes 室內裝修物料

House 1 and House 2

Item	Description
(a) Lobby	<b>Wall</b> - The walls of Private Basement Lift Lobby at House 1 are finished with gypsum board finished with emulsion paint to the exposed surface. - The walls of Private Basement Lift Lobby at House 2 are finished with emulsion paint to the exposed surface.
	<b>Floor</b> - Natural stone to the exposed surface for flooring.
	<b>Ceiling</b> - Suspended gypsum board false ceiling and finished with emulsion paint.
(b) Internal Wall and Ceiling	<b>Internal Wall</b> - Internal walls of Living Room at House 1 are finished with natural stone, wood veneer, special glass and emulsion paint to exposed surface. - Internal walls of Living Room at House 2 are finished with emulsion paint to exposed surface. - Internal walls of Dining Room are finished with natural stone and emulsion paint to exposed surface. - Internal walls of Master Bedroom, Bedroom 2, Bedroom 3 and Bedroom 4 at House 1 are finished with emulsion paint, wallpaper, fabric and metal to exposed surface. - Internal walls of Bedrooms at House 2 are finished with emulsion paint to exposed surface.
	<b>Ceiling</b> - Ceilings of Living Room, Dining Room and Bedrooms are suspended gypsum board false ceiling with emulsion paint.
(c) Internal Floor	<b>Living Room</b> - Engineered timber flooring to the exposed surface and natural stone border along inside edge of floor in front of sliding door opening to garden.
	<b>Dining Room</b> - Engineered timber flooring and natural stone to the exposed surface and natural stone border along inside edge of floor in front of sliding door opening to garden.
	<b>Bedroom 2 and Bedroom 4 at House 2</b> - Engineered timber flooring to the exposed surface.
	<b>Master Bedroom, Bedroom 2, Bedroom 3 and Bedroom 4 at House 1 and Master Bedroom and Bedroom 3 of House 2</b> - Engineered timber flooring to the exposed surface and natural stone border along inside edge of floor in front of sliding door opening of balcony / utility platform / flat roof door / in front of curtain wall.
	<b>Living Room, Dining Room and Bedrooms</b> - Wood panel with emulsion paint for skirting.

1 號洋房及 2 號洋房

細項	描述
(a) 大堂	<b>牆壁</b> - 1 號洋房之私人地庫升降機大堂的牆身外露部分鋪砌石膏板及髹乳膠漆。 - 2 號洋房之私人地庫升降機大堂的牆身外露部分髹乳膠漆。
	<b>地板</b> - 地板外部分露鋪砌天然石。
	<b>天花板</b> - 石膏板假天花及髹乳膠漆。
(b) 內牆及天花板	<b>內牆</b> - 1 號洋房之客廳外露牆身鋪砌天然石、木皮飾面、特色玻璃及乳膠漆。 - 2 號洋房之客廳外露牆身髹乳膠漆。 - 飯廳外露牆身鋪砌天然石及髹乳膠漆。 - 1 號洋房之主人睡房、睡房 2、睡房 3 及睡房 4 外露牆身髹乳膠漆、牆紙、布藝及金屬。 - 2 號洋房之睡房外露牆身髹乳膠漆。
	<b>天花板</b> - 客廳、飯廳及睡房設石膏板假天花及髹乳膠漆。
(c) 內部地板	<b>客廳</b> - 地板外露部分鋪砌複合木地板；另通往花園的趟門的室內地台圍邊部分鋪砌天然石。
	<b>飯廳</b> - 地板外露部分鋪砌複合木地板及天然石；另通往花園的趟門的室內地台圍邊部分鋪砌天然石。
	<b>2 號洋房之睡房 2 及睡房 4</b> - 地板外露部分鋪砌複合木地板。
	<b>1 號洋房之主人睡房、睡房 2、睡房 3 及睡房 4 及 2 號洋房之主人睡房及睡房 3</b> - 地板外露部分鋪砌複合木地板；另通往露台 / 工作平台 / 平台門的趟門 / 玻璃幕牆前的室內地台圍邊部分鋪砌天然石
	<b>客廳、飯廳及睡房</b> - 髹乳膠漆面木腳線。

## FITTINGS, FINISHES AND APPLIANCES 裝置、裝修物料及設備

### 2. Interior Finishes 室內裝修物料

House 1 and House 2

Item	Description
(d) Bathroom	Except Bathroom 7 at House 1 and Lavatories - Natural stone to the exposed surfaces for wall.
	Bathroom 7 at House 1 - Natural stone and metal finishes to the exposed surface for wall.
	Lavatories - Porcelain tiles to the exposed surface for wall.
	Except Bathroom 2 at House 1 and Lavatories - Natural stone to the exposed surfaces for flooring.
	Bathroom 2 at House 1 - Natural stone and carpet to the exposed surface for flooring.
	Lavatories - Porcelain tiles to the exposed surface for flooring.
	All Bathrooms and Lavatories - Suspended gypsum board false ceiling and painted with emulsion paint.
	All Bathrooms and Lavatories - Wall finishes run up to false ceiling level. No finishes to be provided above false ceiling level.
(e) Kitchen	- Natural stone to the exposed surfaces for wall. - Porcelain tiles to the exposed surfaces for flooring. - Suspended gypsum board false ceiling with emulsion paint. - Cooking bench is finished with natural stone. - Wall finishes run up to false ceiling level. No finishes to be provided above false ceiling level.

1 號洋房及 2 號洋房

細項	描述
(d) 浴室	1 號洋房浴室 7 及洗手間除外 - 牆身外露部分鋪砌天然石。
	1 號洋房浴室 7 - 牆身外露部分鋪砌天然石及金屬飾面。
	洗手間 - 牆身外露部分鋪砌磁磚。
	1 號洋房浴室 2 及洗手間除外 - 地台外露部分鋪砌天然石。
	1 號洋房浴室 2 - 地台外露部分鋪砌天然石及地毯。
	洗手間 - 地台外露部分鋪砌磁磚。
	所有浴室及洗手間 - 石膏板假天花及髹乳膠漆。
	所有浴室及洗手間 - 牆身飾面鋪至假天花，假天花以上沒有提供。
(e) 廚房	- 牆身外露部分鋪砌天然石。 - 地台外露部分鋪砌磁磚。 - 石膏板假天花及髹乳膠漆。 - 灶台採用天然石材。 - 牆身飾面鋪至假天花，假天花以上沒有提供。

## FITTINGS, FINISHES AND APPLIANCES 裝置、裝修物料及設備

### 3. Interior Fittings 室內裝置

House 1 and House 2

Item	Description
(a) Doors	Entrance Door - Metal framed swing door finished with metal, wood veneered panel and mirror, fitted with lockset and door handle.
	Parking Space to Lift Lobby Door - Solid core fire rated timber swing door finished with mold proof paint, fitted with electrical lockset, door handle and door closer.
	Parking Space to Fire Services Pump Room Door - Solid core fire rated timber swing door finished with mold proof paint, fitted with door handle, lockset, door closer and door stopper.
	Potable Water and Flushing Water Pump Room Door - Solid core fire rated timber swing door finished with mold proof paint, fitted with door handle, lockset, door closer and door stopper.
	Fire Services Pump Room Door for House 1 - Solid core fire rated timber swing door finished with mold proof paint, fitted with door handle, lockset and door closer.
	Fire Services Pump Room Door for House 2 - Solid core fire rated timber swing door finished with mold proof paint, fitted with door handle, lockset, door closer and door stopper.
	Extra Low Voltage Room Door for House 1 - Solid core fire rated timber swing door finished with mold proof paint, fitted with door handle, lockset and door closer.
	Extra Low Voltage Room Door for House 2 - Solid core fire rated timber swing door finished with mold proof paint, fitted with door handle, lockset, door closer and door stopper.
	Electrical Room Door for House 1 - Solid core fire rated timber swing door finished with mold proof paint, fitted with door handle, lockset and door closer.
	Electrical Room Door for House 2 - Solid core fire rated timber swing door finished with mold proof paint, fitted with door handle, lockset, door closer and door stopper.
	Lift Lobby Door - Solid core fire rated timber swing door finished with mold proof paint, fitted with door handle and door closer.
	Potable Water and Flushing Water Pump Room to Parking Space Door at House 1 - Solid core fire rated timber swing door finished with mold proof paint, fitted with door handle, door closer and door stopper.
	Gas Meter Cabinet Door - Solid core fire rated timber swing door finished with mold proof paint, fitted with door handle and lockset.
	Fire Services Water Meter Cabinet Door - Solid core fire rated timber swing door finished with mold proof paint, fitted with door handle and lockset.
Living Room to Garden Door - Fluorocarbon coated aluminum framed glass (Insulated Glazing Unit (IGU) with low-e coating) sliding door fitted with electrical motor drive and electrical magnetic lock.	

1 號洋房及 2 號洋房

細項	描述
(a) 門	大門 - 金屬框掩門配金屬、木皮飾面板及鏡，裝設門鎖及門柄。
	停車位通往升降機大堂門 - 防霉油漆飾面實心防火木掩門，裝設電子門鎖、門柄及門鼓。
	停車位通往消防泵房門 - 防霉油漆飾面實心防火木掩門，裝設門鎖、門柄、門鼓及門擋。
	食水及沖廁水泵房門 - 防霉油漆飾面實心防火木掩門，裝設門鎖、門柄、門鼓及門擋。
	1 號洋房的消防泵房門 - 防霉油漆飾面實心防火木掩門，裝設門鎖、門柄及門鼓。
	2 號洋房的消防泵房門 - 防霉油漆飾面實心防火木掩門，裝設門鎖、門柄、門鼓及門擋。
	1 號洋房的低電壓房門 - 防霉油漆飾面實心防火木掩門，裝設門鎖、門柄及門鼓。
	2 號洋房的低電壓房門 - 防霉油漆飾面實心防火木掩門，裝設門鎖、門柄、門鼓及門擋。
	1 號洋房的電錶房門 - 防霉油漆飾面實心防火木掩門，裝設門鎖、門柄及門鼓。
	2 號洋房的電錶房門 - 防霉油漆飾面實心防火木掩門，裝設門鎖、門柄、門鼓及門擋。
	升降機大堂門 - 防霉油漆飾面實心防火木掩門，裝設門柄及門鼓。
	1 號洋房的食水及沖廁水泵房通往停車位的門 - 防霉油漆飾面實心防火木掩門，裝設門柄、門鼓及門擋。
	煤氣錶箱門 - 防霉油漆飾面實心防火木掩門，裝設門柄及門鎖。
	消防水錶箱門 - 防霉油漆飾面實心防火木掩門，裝設門柄及門鎖。
客廳通往花園門 - 氟碳噴塗鋁框玻璃(雙層中空玻璃配低輻射鍍膜)趟門，裝設電動馬達及電動磁力鎖。	

## FITTINGS, FINISHES AND APPLIANCES 裝置、裝修物料及設備

### 3. Interior Fittings 室內裝置

House 1 and House 2

Item	Description
(a) Doors	Dining Room to Garden Door - Fluorocarbon coated aluminum framed glass (Insulated Glazing Unit (IGU) with low-e coating) sliding door fitted with electrical motor drive and electrical magnetic lock.
	Kitchen to Garden Door at House 1 - Fluorocarbon coated aluminum framed glass (Insulated Glazing Unit (IGU) with low-e coating) swing door fitted with door handle with lockset.
	Library Door at House 1 - Solid core timber sliding door finished with emulsion paint, fitted with door handle.
	Kitchen to Dining Room Door - Solid core fire rated timber swing door finished with emulsion paint, fitted with door handle, door closer and door stopper.
	G/F Lavatory Door at House 2 - Solid core timber swing door finished with emulsion paint, fitted with door handle and lockset.
	Bathroom Door (Except Bathroom 1 Door and Bathroom 2 Door at House 1 and House 2) - Solid core timber swing door finished with emulsion paint, fitted with robe hook, door handle, lockset and door stopper.
	Bathroom 1 Door at House 1 - Solid core timber sliding door finished with emulsion paint, fitted with door handle and lockset.
	Bathroom 2 Door at House 1 - Solid core timber swing door finished with emulsion paint, fitted with door handle, lockset and door stopper.
	Bathroom 1 Door at House 2 - Solid core timber swing door finished with emulsion paint, fitted with door handle, lockset and door stopper.
	Bathroom 2 Door at House 2 - Solid core timber swing door finished with emulsion paint, fitted with door handle, lockset and door stopper.
	G/F Internal Staircase to Basement Door - Solid core fire rated timber swing door finished with emulsion paint, fitted with door handle, door closer and door stopper.
	Foyer to Garden Door at House 1 - Fluorocarbon coated aluminum framed glass (Insulated Glazing Unit (IGU) with low-e coating) swing door, fitted with door handle and lockset.
	Library to Garden Door at House 1 - Fluorocarbon coated aluminum framed glass (Insulated Glazing Unit (IGU) with low-e coating) sliding door, fitted with door handle and lockset.
	Gate at House Side Corridor to Car Ramp at House 1 - Metal swing gate finished with powder coating, fitted with door handle, electrical lockset, break glass door opener, door opening button and door latch.
	Store Room Door at House 2 - Solid core timber swing door finished with emulsion paint, fitted with door handle, lockset and door stopper.

1 號洋房及 2 號洋房

細項	描述
(a) 門	飯廳通往花園門 - 氟碳噴塗鋁框玻璃(雙層中空玻璃配低輻射鍍膜)趟門,裝設電動馬達及電動磁力鎖。
	1 號洋房的廚房通往花園門 - 氟碳噴塗鋁框玻璃(雙層中空玻璃配低輻射鍍膜)掩門,裝設門柄連門鎖。
	1 號洋房的圖書房門 - 實心木趟門髹乳膠漆,裝設門柄。
	廚房通往飯廳門 - 實心防火木掩門髹乳膠漆,裝設門柄、門鼓及門擋。
	2 號洋房的地下洗手間門 - 實心木掩門髹乳膠漆,裝設門柄及門鎖。
	浴室門(1 號洋房及 2 號洋房的浴室 1 門及浴室 2 門除外) - 實心木掩門髹乳膠漆,裝設衣鈎、門柄、門鎖及門擋。
	1 號洋房的浴室 1 門 - 實心木趟門髹乳膠漆,裝設門柄及門鎖。
	1 號洋房的浴室 2 門 - 實心木掩門髹乳膠漆,裝設門柄、門鎖及門擋。
	2 號洋房的浴室 1 門 - 實心木掩門髹乳膠漆,裝設門柄、門鎖及門擋。
	2 號洋房的浴室 2 門 - 實心木掩門髹乳膠漆,裝設門柄、門鎖及門擋。
	地下室內樓梯通往地庫門 - 實心防火木掩門髹乳膠漆,裝設門柄、門鼓及門擋。
	1 號洋房的玄關通往花園門 - 氟碳噴塗鋁框玻璃(雙層中空玻璃配低輻射鍍膜)掩門,裝設門柄及門鎖。
	1 號洋房的圖書房通往花園門 - 氟碳噴塗鋁框玻璃(雙層中空玻璃配低輻射鍍膜)趟門,裝設門柄及門鎖。
	1 號洋房的屋側通往車路之閘 - 粉末噴塗飾面金屬掩閘,裝設門柄、電子鎖、打破玻璃緊急開門掣、開門掣及門扣。
	2 號洋房的儲物房門 - 實心木掩門髹乳膠漆,裝設門柄、門鎖及門擋。

## FITTINGS, FINISHES AND APPLIANCES

### 裝置、裝修物料及設備

#### 3. Interior Fittings 室內裝置

House 1 and House 2

Item	Description
(a) Doors	Store Room Door (under G/F internal staircase) at House 2 - Solid core timber swing door finished with emulsion paint, fitted with door handle, lockset and door stopper.
	Kitchen to Common Area Door at House 2 - Fluorocarbon coated aluminum framed glass (Insulated Glazing Unit (IGU) with low-e coating) swing door, fitted with door handle, lockset and door closer.
	Garden to Common Area Gate at House 2 - Metal swing gate finished with powder coating, fitted with door handle and door latch.
	Garden to Drainage Reserve Area Gate at House 2 - Metal swing gate finished with powder coating, fitted with door latch.
	G/F Side Gate to Common Area at House 2 - Metal swing gate finished with powder coating, fitted with door handle and door latch.
	Main Gate to Lok Chui Street - Metal swing gate finished with powder coating, fitted with door handle, electrical lockset, break glass door opener and door opening button.
	Bedroom Door - Solid core timber swing door finished with emulsion paint, fitted with door handle, lockset and door stopper.
	1/F Walk-in Closet Door at House 1 - Solid core timber swing door finished with emulsion paint, fitted with door handle and lockset.
	2/F Walk-in Closet Door at House 1 - Solid core timber sliding door finished with emulsion paint, fitted with door handle and lockset.
	Game Room Door at House 1 - Solid core timber sliding door finished with emulsion paint, fitted with door handle.
	Utility Room Door - Solid core timber swing door finished with emulsion paint, fitted with door handle, lockset and door stopper.
	Lavatory Door in Utility Room - Aluminum framed folding door finished with paint and frosted glass fitted with door handle and lockset.
	Flat Roof Door - Fluorocarbon coated aluminum framed glass (Insulated Glazing Unit (IGU) with low-e coating) sliding door, fitted with door handle and lockset.
	Utility Platform Door - Fluorocarbon coated aluminum framed glass (Insulated Glazing Unit (IGU) with low-e coating) sliding door, fitted with door handle and lockset.
	Balcony Door - Fluorocarbon coated aluminum framed glass (Insulated Glazing Unit (IGU) with low-e coating) sliding door, fitted with door handle and lockset.
Store Room Door at House 1 - Steel framed swing door finished with paint and mirror, fitted with lockset with handle wheel and door stopper.	

1 號洋房及 2 號洋房

細項	描述
(a) 門	2 號洋房的儲物房門 (設於地下室內樓梯底) - 實心木掩門髹乳膠漆, 裝設門柄、門鎖及門擋。
	2 號洋房的廚房通往公用地方之門 - 氟碳噴塗鋁框玻璃 (雙層中空玻璃配低輻射鍍膜) 掩門, 裝設門柄、門鎖及門鼓。
	2 號洋房的花園通往公用地方之閘 - 粉末噴塗飾面金屬掩閘, 裝設門柄及門扣。
	2 號洋房的花園通往排水系統專用範圍之閘 - 粉末噴塗飾面金屬掩閘, 裝設門扣。
	2 號洋房的地下通往公用地方之側閘 - 粉末噴塗飾面金屬掩閘, 裝設門柄及門扣。
	通往樂翠街之大閘 - 粉末噴塗飾面金屬掩閘, 裝設門柄、電子鎖、打破玻璃緊急開門掣及開門掣。
	睡房門 - 實心木掩門髹乳膠漆, 裝設門柄、門鎖及門擋。
	1 號洋房的 1 樓衣帽間門 - 實心木掩門髹乳膠漆, 裝設門柄及門鎖。
	1 號洋房的 2 樓衣帽間門 - 實心木趟門髹乳膠漆, 裝設門柄及門鎖。
	1 號洋房的遊戲房門 - 實心木趟門髹乳膠漆, 裝設門柄。
	工作間門 - 實心木掩門髹乳膠漆, 裝設門柄、門鎖及門擋。
	工作間內的洗手間門 - 磨砂玻璃及油漆飾面鋁框摺門, 裝設門柄及門鎖。
	平台門 - 氟碳噴塗鋁框玻璃 (雙層中空玻璃配低輻射鍍膜) 趟門, 裝設門柄及門鎖。
	工作平台門 - 氟碳噴塗鋁框玻璃 (雙層中空玻璃配低輻射鍍膜) 趟門, 裝設門柄及門鎖。
	露台門 - 氟碳噴塗鋁框玻璃 (雙層中空玻璃配低輻射鍍膜) 趟門, 裝設門柄及門鎖。
1 號洋房的儲物房門 - 金屬框掩門髹油漆及配鏡飾面, 裝設門鎖連環形門柄及門擋。	

## FITTINGS, FINISHES AND APPLIANCES 裝置、裝修物料及設備

### 3. Interior Fittings 室內裝置

House 1 and House 2

Item	Description
(a) Doors	2/F Corridor Door at House 1 - Solid core timber swing door finished with emulsion paint, fitted with door handle, lockset and door stopper.
	Bathroom 1 to Walk-in Closet Door at House 2 - Solid core timber swing door finished with emulsion paint, fitted with door handle, lockset and door stopper.
	Master Bedroom to Walk-in Closet Door at House 2 - Solid core timber swing door finished with emulsion paint, fitted with door handle, lockset and door stopper.
	Internal Staircase Door to Roof - Fluorocarbon coated aluminum framed glass (Insulated Glazing Unit (IGU) with low-e coating) swing door, fitted with door handle and lockset.
	Roof Gate to Water Heater and Air-conditioner Outdoor Plant at House 1 - Metal swing gate finished with powder coating fitted with door handle and lockset.
	Roof Gate to Air-conditioner Outdoor Plant at House 2 - Metal swing gate finished with powder coating fitted with door handle and door latch.
	Roof Water Heater Cabinet Door at House 1 - Metal framed swing door with metal louvre finished with powder coating fitted with door handle.
	Garden Side Gate at House 1 - Metal swing gate finished with powder coating fitted with door handle and lockset

1 號洋房及 2 號洋房

細項	描述
(a) 門	1號洋房的2樓走廊門 - 實心木掩門髹乳膠漆, 裝設門柄、門鎖及門擋。
	2號洋房的浴室1通往衣帽間門 - 實心木掩門髹乳膠漆, 裝設門柄、門鎖及門擋。
	2號洋房的主人睡房通往衣帽間門 - 實心木掩門髹乳膠漆, 裝設門柄、門鎖及門擋。
	室內樓梯通往天台門 - 氟碳噴塗鋁框玻璃(雙層中空玻璃配低輻射鍍膜) 掩門, 裝設門柄及門鎖。
	1號洋房通往熱水爐及室外空調機之天台閘 - 粉末噴塗飾面金屬掩閘, 裝設門柄及門鎖。
	2號洋房通往室外空調機之天台閘 - 粉末噴塗飾面金屬掩閘, 裝設門柄及門扣。
	1號洋房天台熱水爐櫃門 - 粉末噴塗飾面金屬框金屬百葉掩門, 裝設門柄。
	1號洋房的花園之側閘 - 粉末噴塗飾面金屬掩閘, 裝設門柄及門鎖。

## FITTINGS, FINISHES AND APPLIANCES

### 裝置、裝修物料及設備

#### 3. Interior Fittings 室內裝置

House 1 and House 2

Item	Description
(b) Bathroom	Bathrooms Fitted with sanitary wares and fittings including natural stone basin counter top (Except Bathroom 7 at House 1), wooden basin cabinet finished with wood veneered panel and metal (Except Bathroom 7 at House 1), metal framed glass mirror cabinet with mirror panel, metal framed mirror (For Bathroom 1, Bathroom 2, Bathroom 4, Bathroom 7 at House 1 and Bathroom 1, Bathroom 3 and Bathroom 4 at House 2 only), wooden wardrobe finished with paint, fabric, clear glass and metal finishes and metal handle (For Bathroom 2 at House 1 only), brass wash basin mixer, vitreous china wash basin, vitreous china water closet, brass toilet paper roll holder, brass robe hook (For Bathroom 1 at House 1 and Bathroom 2 at House 2 only), brass tower rack, fabric roller blind (For Bathroom 2 at House 2 only), brass shower set, brass bath mixer, reconstituted stone bath tub (Except Bathroom 6 and Bathroom 7 at House 1 and Bathroom 5 at House 2) (for Bathroom 1 and Bathroom 2 at House 1 and House 2: 1800mm(L) x 850mm(W) x 600mm(H); for Bathroom 3, Bathroom 4 and Bathroom 5 at House 1 and Bathroom 3 and Bathroom 4 at House 2: 1500mm(L) x 800mm(W) x 550mm(H)) and tempered glass with steel frame shower cubicle.
	Lavatories (Except Lavatory at G/F of House 2) Fitted with sanitary wares and fittings including vitreous china wash basin, vitreous china water closet, Chrome plated wash basin mixer, Chrome plated toilet paper roll holder and Chrome plated shower mixer set.
	Lavatory at G/F of House 2 Fitted with sanitary wares and fittings including natural stone basin counter top, wooden basin cabinet finished with wood veneered panel and metal, metal framed glass mirror cabinet with mirror panel, vitreous china wash basin, vitreous china water closet, brass wash basin mixer, brass toilet paper roll holder and brass robe hook.
	For type and material of water supply system, please refer to "Water Supply" below.
(c) Kitchen	Fitted with wooden kitchen cabinet finished with painted wood panel doors and composite stone sink with electroplated metal mixer.
	For material of water supply system, please refer to "Water Supply" below.
	For appliances provision and brand names, please refer to "Appliances Schedule" below.
(d) Bedroom	Bedroom 2 and Bedroom 4 at House 1 - Fitted with built-in wooden wardrobe finished with paint and metal handle. - Fitted with built-in wooden wardrobe with stainless steel framed glass door panel, mirror and metal handle.
	Bedroom 3 at House 1 - Fitted with built-in painted wooden wall shelf.
	Master Bedroom, Bedroom 2, Bedroom 3 and Bedroom 4 at House 1 - Fitted with motorized fabric curtain.
	Master Bedroom at House 2 - Fitted with built-in painted wooden wardrobe, fabric, metal finishes and metal handle. - Fitted with fabric curtain.
(e) Telephone	Not provided.

1 號洋房及 2 號洋房

細項	描述
(b) 浴室	浴室 配有衛生潔具和配件包括天然石洗手盆檯面 (1 號洋房浴室 7 除外)、木製洗手盆櫃配以木皮飾面及金屬 (1 號洋房浴室 7 除外)、金屬框玻璃鏡櫃配以鏡飾面板、金屬框連鏡 (適用於 1 號洋房浴室 1、浴室 2、浴室 4、浴室 7 及 2 號洋房浴室 1、浴室 3 及浴室 4)、木製衣櫃配髹漆、布藝、清玻璃及金屬飾面及金屬拉手 (適用於 1 號洋房浴室 2)、銅洗手盆水龍頭、陶瓷洗手盆、陶瓷座廁、銅廁紙架、銅衣鉤 (適用於 1 號洋房浴室 1 及 2 號洋房浴室 2)、銅毛巾架、布質捲簾 (適用於 2 號洋房浴室 2)、銅花灑套裝、銅浴缸水龍頭、人造石材浴缸 (1 號洋房浴室 6 及浴室 7 及 2 號洋房浴室 5 除外) (適用於 1 號洋房及 2 號洋房浴室 1 及浴室 2: 1800 毫米 (長) x 850 毫米 (闊) x 600 毫米 (高); 適用於 1 號洋房浴室 3、浴室 4 及浴室 5 及 2 號洋房浴室 3 及浴室 4: 1500 毫米 (長) x 800 毫米 (闊) x 550 毫米 (高)) 及強化玻璃連鋼框淋浴間。
	洗手間 (2 號洋房地下洗手間除外) 配有衛生潔具和配件包括陶瓷洗手盆、陶瓷座廁、鍍鉻洗手盆水龍頭、鍍鉻廁紙架及鍍鉻花灑水龍頭套裝。
	2 號洋房地下洗手間 配有衛生潔具和配件包括天然石洗手盆檯面、木製洗手盆櫃配以木皮飾面及金屬、金屬框玻璃鏡櫃配以鏡飾面板、陶瓷洗手盆、陶瓷座廁、銅洗手盆水龍頭、銅廁紙架及銅衣鉤。
	供水系統的類型和用料請參考以下的“供水”。
(c) 廚房	裝設木製廚櫃配焗漆飾面門板、合成人造石洗滌盤配鍍金屬水龍頭。
	供水系統的用料請參考以下的“供水”。
	有關家電配置和品牌名稱，請參閱以下的“設備說明表”。
(d) 睡房	1 號洋房的睡房 2 及睡房 4 - 嵌入式木製衣櫃，配髹漆飾面及金屬拉手。 - 嵌入式木製衣櫃，配不銹鋼框玻璃門板、鏡及金屬拉手。
	1 號洋房的睡房 3 - 嵌入式木製牆架，配髹漆飾面。
	1 號洋房的主人睡房、睡房 2、睡房 3 及睡房 4 - 配以電動布質窗簾。
	2 號洋房的主人睡房 - 嵌入式木製衣櫃，配髹漆、布藝及金屬飾面及金屬拉手。 - 配以布質窗簾。
(e) 電話	未有提供。

## FITTINGS, FINISHES AND APPLIANCES 裝置、裝修物料及設備

### 3. Interior Fittings 室內裝置

House 1 and House 2

Item	Description
(f) Aerials	For the numbers and location of connection points, please refer to “Schedule of Mechanical and Electrical Provisions of Residential Units” .
(g) Electrical Installations	Faceplate for all switches and power sockets are provided. Miniature circuit breaker distribution board is provided for each House.
	Conduits are partly concealed and partly exposed. Other than those parts of the conduits concealed within concrete, the rest of them are exposed. Exposed conduits may be covered or hidden by false ceiling, bulkheads, cabinets, claddings, non-concrete partition walls, designated pipe ducts or other material.
	For the numbers and location of power points and air-conditioner points, please refer to “Schedule of Mechanical and Electrical Provisions of Residential Units” .
(h) Gas Supply	Town gas supply pipe is provided and connected to gas hob.
	For the locations, please refer to “Schedule of Mechanical and Electrical Provisions of Residential Units” .
(i) Washing Machine Connection Point	Water inlet connection point of a design of 18mm in diameter and water outlet connection point of a design of 40mm in diameter are provided for washing machine.
	For the location of connection points, please refer to “Schedule of Mechanical and Electrical Provisions of Residential Units” .
(j) Water Supply	Copper water pipes for cold and hot water supply system. Water pipes are partly concealed and partly exposed. Other than those parts of the water pipes concealed within concrete, the rest of them are exposed. The exposed water pipes may be covered or hidden by false ceilings, bulkheads, cabinets, claddings, non-concrete partition walls, designated pipe ducts or other materials.
	Hot water supply is available.

1 號洋房及 2 號洋房

細項	描述
(f) 天線	有關接駁點的數量及位置，請參閱「住宅單位機電裝置數量說明表」。
(g) 電力裝置	提供開關掣及插座之面板，每戶均裝有微型斷路器配電箱。
	導管部份隱藏及部份外露，除部份隱藏於混凝土內之導管外，其他部份的導管均為外露，外露的導管可能被假天花、假陣、貯存櫃、覆面、非混凝土間牆、指定之槽位或其他物料遮蓋或隱藏。
	有關電插座及空調機接駁點的數目及位置，請參閱「住宅單位機電裝置數量說明表」。
(h) 氣體供應	設置煤氣喉接駁煤氣煮食爐。
	有關位置，請參閱「住宅單位機電裝置數量說明表」。
(i) 洗衣機接駁點	提供其設計為直徑 18 毫米的洗衣機來水接駁喉位及其設計為直徑 40 毫米的去水接駁喉位。
	有關接駁點的位置，請參閱「住宅單位機電裝置數量說明表」。
(j) 供水	冷熱水供水系統採用銅喉管。水管部份隱藏及部份外露，除部份隱藏於混凝土內之水管外，其他部份的水管均為外露，外露的水管可能被假天花、假陣、貯存櫃、覆面、非混凝土間牆、指定之槽位或其他物料遮蓋或隱藏。
	有熱水供應。

## FITTINGS, FINISHES AND APPLIANCES 裝置、裝修物料及設備

### 4. Miscellaneous 雜項

Item	Description
(a) Lift	1 no. of "Mitsubishi" lift (model no. Elenessa-MRL) for each house. Floor served: B/F, G/F, 1/F, 2/F
(b) Letter Box	A stainless steel letter box is provided.
(c) Refuse Collection	Refuse will be collected by cleaner and centrally handled at Refuse Chamber Room on G/F.
(d) Water Meter, Electricity Meter and Gas Meter	Separate meter for potable water is provided in Common Water Meter Cabinet on B/F.
	Separate meter for electricity is provided in Eletrical Room on B/F.
	Separate meter for town gas is provided in Gas Meter Cabinet of each house on B/F.

細項	描述
(a) 升降機	每間洋房設有 1 部「三菱」電梯 (型號 Elenessa-MRL)。到達樓層: 地庫, 地下, 一樓, 二樓
(b) 信箱	提供 1 個不銹鋼信箱。
(c) 垃圾收集	垃圾將由清潔工人收集及送走。垃圾收集處於地下。
(d) 水錶、電錶及氣體錶	獨立水錶安裝於地庫之公共水錶櫃內。
	獨立電錶安裝於地庫之電錶房內。
	獨立煤氣錶安裝於每間洋房地庫的煤氣錶箱櫃內。

### 5. Security Facilities 保安設施

<b>For House:</b>
CCTV cameras are provided at B/F Lift Lobby, Lift Car and Garden area. Magnetic door contacts are provided to entrance doors and magnetic window contacts are provided to all operable windows. Video door phone handsets are installed at the Foyer and Family Room at House 2. Tablets for monitoring the security system are provided at the Foyer, Bedroom 3, Master Bedroom and Utility Room at House 1.
<b>For Common Area:</b>
CCTV cameras are provided at B/F Carpark. Electrical fence system, CCTV cameras, flood lights and infrared thermal cameras are provided at the boundary of the Development.
For the location of glass break detector, magnetic door/window contact and video doorphone, please refer to "Schedule of Mechanical and Electrical Provisions of Residential Units".

<b>洋房:</b>
閉路電視攝像機安裝於地庫電梯大堂、電梯及花園位置。大門安裝磁性感應防盜。所有窗戶安裝磁性感應防盜。2 號洋房的地下玄關及家庭廳安裝大門視頻對講機。平板電腦安裝於 1 號洋房的地下玄關、睡房 3、主人睡房及工作間。
<b>公用地方:</b>
地庫停車場安裝閉路電視攝像機。發展項目的外圍均安裝保安電網、閉路電視攝像機、泛光燈、紅外線測溫閉路電視攝像機。
有關玻璃破碎感測器、門/窗磁性感應防盜及視像對講機的位置, 請參閱「住宅單位機電裝置數量說明表」。

### 6. Appliances 設備

Please see the "Appliances Schedule".

請參閱「設備說明表」。

Note:  
The vendor undertakes that if lifts or appliances of the specified brand name or model number as stated respectively in items 4(a) and 6 are not installed in the development, lifts or appliances of comparable quality will be installed.

備註:  
賣方承諾如該項目中沒有安裝於第 4(a) 及 6 項所指明的品牌名稱或產品型號的升降機或設備, 便會安裝品質相若的升降機或設備。

## FITTINGS, FINISHES AND APPLIANCES 裝置、裝修物料及設備

### Appliances Schedule 設備說明表

House 1 and House 2  
1 號洋房及 2 號洋房

Location 位置	Appliance 設備	Brand Name 品牌名稱	Model Number 型號	House 1 1 號洋房	House 2 2 號洋房
Kitchen 廚房	Built-in Dishwasher 嵌入式洗碗碟機	Miele	G7150C SCVi	V	V
Kitchen 廚房	Cooker Hood 抽油煙機	Miele	DA4228W	V	V
Kitchen 廚房	Built-in Double Gas Burner 嵌入式煤氣雙頭煮食爐	Miele	CS1013-1	V	V
Kitchen 廚房	Induction Hob 嵌入式電磁爐	Miele	CS1212-1I	V	V
Kitchen 廚房	Built-in Gas Burner 嵌入式煤氣煮食爐	Miele	CS1018G	V	V
Kitchen 廚房	Built-in Oven 嵌入式焗爐	Miele	H7890BP	V	V
Kitchen 廚房	Built-in Microwave Oven 嵌入式微波爐	Miele	M7244TC	V	V
Kitchen 廚房	Built-in Steam Oven 嵌入式蒸爐	Miele	DG7240	V	V
Kitchen 廚房	Built-in Fridge - Freezer 嵌入式雪櫃	Miele	KFNS37432iD	V	V
Kitchen 廚房	Freestanding Washing Machine 獨立式洗衣機	Miele	WED125	V	V
Kitchen 廚房	Freestanding Dryer 獨立式乾衣機	Miele	TEB 145WP	V	V
Dining Room 飯廳	Fully Integrated Fridge - Freezer 嵌入式雪櫃	Miele	KF2911Vi	V	V
Dining Room 飯廳	Built-in Wine Cellar 嵌入式酒櫃	Miele	KWT2611 Vi	V	V
Dining Room 飯廳	Induction Hob 嵌入式電磁爐	Miele	KMDA7633FL	V	V
1/F Store Room and 2/F Corridor 一樓儲物房及二樓走廊	Built-in Microwave Oven 嵌入式微波爐	Miele	M7244TC	V	-
1/F Store Room and 2/F Corridor 一樓儲物房及二樓走廊	Built-under Wine Cellar 嵌入式酒櫃	Miele	KWT6321UG	V	-
1/F Store Room and 2/F Corridor 一樓儲物房及二樓走廊	Built-in Coffee Maker 嵌入式咖啡機	Miele	CVA7440	V	-
1/F Store Room and 2/F Corridor 一樓儲物房及二樓走廊	Built-under Refrigerator 嵌入式雪櫃	Miele	K31222Ui	V	-
1/F Bathroom 4 一樓浴室 4	Floor Heat System 地暖系統	Raychem	T2BLUE-20W/M	V	V
1/F Bathroom 5 一樓浴室 5	Floor Heat System 地暖系統	Raychem	T2BLUE-20W/M	V	V
2/F Bathroom 1 二樓浴室 1	Floor Heat System 地暖系統	Raychem	T2BLUE-20W/M	V	V
2/F Bathroom 2 二樓浴室 2	Floor Heat System 地暖系統	Raychem	T2BLUE-20W/M	V	V
2/F Bathroom 3 二樓浴室 3	Floor Heat System 地暖系統	Raychem	T2BLUE-20W/M	V	V
Roof 天台	Water Heater 熱水爐	TGC	TSTW220TFQL	V	-
Upper Roof 上層天台	Water Heater 熱水爐	TGC	TSTW220TFQL	-	V

The vendor undertakes that if lifts or appliances of the specified brand name or model number are not installed in the Development, lifts or appliances of comparable quality will be installed.

**Notes:**

- "v" means such appliance(s) is/are provided and/or installed in the residential unit.
- "-" means "Not Applicable".

賣方承諾如發展項目中沒有安裝指明的品牌名稱或產品型號的升降機或設備，便會安裝品質相若的升降機或設備。

**備註：**

- "v" 表示此設備於該住宅單位內提供及/或安裝。
- "-" 表示「不適用」。

## FITTINGS, FINISHES AND APPLIANCES 裝置、裝修物料及設備

### Appliances Schedule 設備說明表

House 1 and House 2  
1 號洋房及 2 號洋房

Location 位置	Appliance 設備	Brand Name 品牌名稱	Model Number 型號	House 1 1 號洋房	House 2 2 號洋房
2/F Bathroom 3 二樓浴室 3	Thermo Ventilator 浴室換氣暖風機	Panasonic 樂聲牌	FV-30BG2H	V	-
1/F Bathroom 4 一樓浴室 4				V	V
1/F Bathroom 5 一樓浴室 5				V	V
1/F Bathroom 6 一樓浴室 6				V	-
G/F Bathroom 7 地下浴室 7				V	-
1/F Family Room 一樓家庭廳	Video Doorphone 視像對講機	2N	Indoor View Intercom	-	V
G/F Foyer 地下玄關		2N	Indoor View Intercom	-	V
Ground floor main entrance (Entrance gate) 地下主入口 (大閘)	Visitor Panel 訪客對講機	2N	IP Solo	V	V
G/F Foyer 地下玄關	Control System Panel 控制系統控制屏	Apple	iPad Air 10.9"	V	-
1/F Utility Room 一樓工作間				V	-
1/F Bedroom 3 一樓睡房 3				V	-
2/F Master Bedroom 二樓主人睡房				V	-
Roof 天台	Variable Refrigerant Volume Air Conditioner Outdoor Unit 可變冷媒流量空調機 (室外機)	DAIKIN 大金	RXYQ18TANY1	-	V
			RXYQ20TANY1	V	-
			RXYQ22TASY1	-	V
			RXYQ24TASY1	V	V
B/F Lift Lobby 地庫升降機大堂	Variable Refrigerant Volume Air Conditioner Indoor Unit 可變冷媒流量空調機 (室內機)	DAIKIN 大金	FXDQ50NBVE	V	V
G/F Kitchen 地下廚房			FXDQ50NBVE	V	V
G/F Foyer 地下玄關			FXDQ50NBVE	V	V
G/F Library 地下圖書房			FXDQ63NBVE	V	-
			FXDQ50NBVE	-	V
G/F Living Room 地下客廳			FXDQ63NBVE	V	-
			FXSQ80PVE	-	V
G/F Dining Room 地下飯廳			FXDQ63NBVE	V	-
			FXSQ80PVE	-	V
1/F Walk-in Closet 一樓衣帽間			FXDQ25PBVE	-	V
1/F Bedroom 4 一樓睡房 4			FXDQ63NBVE	V	-
			FXDQ50NBVE	-	V

The vendor undertakes that if lifts or appliances of the specified brand name or model number are not installed in the Development, lifts or appliances of comparable quality will be installed.

Notes:

- "v" means such appliance(s) is/are provided and/or installed in the residential unit.
- "-" means "Not Applicable".

賣方承諾如發展項目中沒有安裝指明的品牌名稱或產品型號的升降機或設備，便會安裝品質相若的升降機或設備。

備註：

- “v”表示此設備於該住宅單位內提供及/或安裝。
- “-”表示「不適用」。

# FITTINGS, FINISHES AND APPLIANCES

## 裝置、裝修物料及設備

### Appliances Schedule 設備說明表

House 1 and House 2  
1 號洋房及 2 號洋房

Location 位置	Appliance 設備	Brand Name 品牌名稱	Model Number 型號	House 1 1 號洋房	House 2 2 號洋房
1/F Game Room 一樓遊戲房	Variable Refrigerant Volume Air Conditioner Indoor Unit 可變冷媒流量空調機 (室內機)	DAIKIN 大金	FXDQ50NBVE	V	-
1/F Bathroom 6 一樓浴室 6			FXDQ50NBVE	V	-
1/F Family Room 一樓家庭廳			FXDQ50NBVE	V	V
1/F Bedroom 3 一樓睡房 3			FXDQ50NBVE	V	V
1/F Walk-in Closet 一樓衣帽間			FXDQ50NBVE	V	V
1/F Store Room 1 樓儲物房			FXDQ32PBVE	V	-
1/F Utility Room 一樓工作間			FXDQ63NBVE	V	V
1/F Corridor 一樓走廊			FXDQ63NBVE	-	V
2/F Bedroom 2 二樓睡房 2			FXDQ63NBVE	V	-
			FXDQ50NBVE	-	V
2/F Fitness Room 二樓健身房			FXDQ50NBVE	V	-
2/F Corridor 二樓走廊			FXDQ50NBVE	V	-
			FXDQ63NBVE	-	V
2/F Bathroom 2 二樓浴室 2			FXDQ50NBVE	V	-
			FXDQ63NBVE	V	V
2/F Master Bedroom 二樓主人睡房			FXDQ63NBVE	V	-
			FXDQ50NBVE	-	V
2/F Walk-in Closet 二樓衣帽間			FXDQ32PBVE	V	-
			FXDQ50NBVE	-	V
2/F Bathroom 1 二樓浴室 1			FXDQ63NBVE	V	-
	FXDQ50NBVE	-	V		
2/F Bathroom 3 二樓浴室 3	FXDQ50NBVE	-	V		
2/F Store Room 二樓儲物房	FXDQ25PBVE	V	V		
Staircase on Roof 天台樓梯			FXAQ50PVE	V	-
			FXAQ63PVE	-	V
Lift 電梯	Air Conditioner 空調機	MIDEA 美的	MWH-09CM3U1	V	V
G/F Kitchen 地下廚房	Exhaust Fan 抽氣扇	Ostberg 奧斯博格	RKB 500X250A1	V	V
G/F Lavatory 地下洗手間			LPK 125A1	-	V
G/F Lavatory 地下洗手間			LPK 125A2	-	V
1/F Lavatory 一樓洗手間			LPK 100A1	V	V

The vendor undertakes that if lifts or appliances of the specified brand name or model number are not installed in the Development, lifts or appliances of comparable quality will be installed.

**Notes:**

- "v" means such appliance(s) is/are provided and/or installed in the residential unit.
- "-" means "Not Applicable".

賣方承諾如發展項目中沒有安裝指明的品牌名稱或產品型號的升降機或設備，便會安裝品質相若的升降機或設備。

**備註:**

- "v" 表示此設備於該住宅單位內提供及/或安裝。
- "-" 表示「不適用」。

## FITTINGS, FINISHES AND APPLIANCES 裝置、裝修物料及設備

### Appliances Schedule 設備說明表

House 1 and House 2  
1 號洋房及 2 號洋房

Location 位置	Appliance 設備	Brand Name 品牌名稱	Model Number 型號	House 1 1 號洋房	House 2 2 號洋房
1/F Store Room 一樓儲物房	Exhaust Fan 抽氣扇	Ostberg 奧斯博格	LPK 200A	V	-
1/F Bathroom 4 一樓浴室 4			LPK 125A1	V	V
1/F Bathroom 5 一樓浴室 5			LPK 125A2	-	V
2/F Store Room 二樓儲物房			LPK 100A1	-	V
2/F Bathroom 1 二樓浴室 1			LPK 200A	V	V
2/F Bathroom 2 二樓浴室 2			LPK 200B	V	V
2/F Bathroom 3 二樓浴室 3			LPK 200A	-	V
B/F Potable Water and Flushing Water Pump Room 地庫食水及沖廁水泵房			RKB 700X400E3	V	-
B/F Potable Water and Flushing Water Pump Room 地庫食水及沖廁水泵房			LPK 200B	-	V
Fire Services Pump Room 消防泵房			LPK 200A	V	V
Extra Low Voltage Room 低電壓房			LPK 200A	V	V
1/F Bathroom 4 一樓浴室 4			Television 電視機	Cristal	BKW22
2/F Bathroom 1 二樓浴室 1	BKW22	V			V
2/F Bathroom 2 二樓浴室 2	BKW22	V			V
1/F Family Room 一樓家庭廳	LG	OLED77C1PCB		V	-
1/F Game Room 一樓遊戲房	Samsung 三星	AU7700 Crystal UHD 4K Smart		V	-
1/F Bedroom 3 一樓睡房 3	LG	OLED65A1PCA		V	-
1/F Bedroom 4 一樓睡房 4	LG	28TN515S		V	-
2/F Master Bedroom 二樓主人睡房	LG	OLED55A1PCA		V	-
G/F Kitchen 地下廚房	Monitor 顯示器	DELL	E2420H	V	-
1/F Utility Room 一樓工作間		DELL	E2420H	V	-
G/F Living Room 地下客廳	Fireplace 壁爐	EcoSmart Fire	XL700	V	-
2/F Master Bedroom 二樓主人睡房			Flex 50SS	V	-

The vendor undertakes that if lifts or appliances of the specified brand name or model number are not installed in the Development, lifts or appliances of comparable quality will be installed.

Notes:

- "v" means such appliance(s) is/are provided and/or installed in the residential unit.
- "-" means "Not Applicable".

賣方承諾如發展項目中沒有安裝指明的品牌名稱或產品型號的升降機或設備，便會安裝品質相若的升降機或設備。

備註：

- "v" 表示此設備於該住宅單位內提供及/或安裝。
- "-" 表示「不適用」。

# FITTINGS, FINISHES AND APPLIANCES

## 裝置、裝修物料及設備

### Schedule of Mechanical and Electrical Provisions of Residential Units

#### 住宅單位機電裝置數量說明表

House 1 and House 2

1 號洋房及 2 號洋房

Floor 樓層	Location 位置	Mechanical and Electrical Provisions 機電裝置	House 1 1 號洋房	House 2 2 號洋房
Basement 地庫	Corridor outside Fire Services Pump Room, Extra Low Voltage Room and Electrical Room (For House 1) 消防泵房、低電壓房及電錶房外走廊 (1 號洋房)	Lighting Point 燈位	5	-
		Switch for Exhaust Fan 抽氣扇開關掣	1	-
		Lighting Switch 燈掣	2	-
	Corridor outside Fire Services Pump Room, Extra Low Voltage Room, Electrical Room and Potable Water and Flushing Water Pump Room (For House 2) 消防泵房、低電壓房、電錶房及食水及沖廁水泵房外走廊 (2 號洋房)	Lighting Point 燈位	-	3
		Lighting Switch 燈掣	-	1
	Extra Low Voltage Room 低電壓房	Lighting Switch 燈掣	-	1
		Lighting Point 燈位	2	2
		Switch for Exhaust Fan 抽氣扇開關掣	-	1
		Fused Spur Unit 接線座連保險絲	1	1
		13A Single Socket Outlet 13 安培單位電插座	11	11
	Electrical Room 電錶房	Lighting Point 燈位	2	2
		Lighting Switch 燈掣	1	1
		MCB Board 總電掣箱	2	2
		MCCB Distribution Board 微型斷路器配電箱	1	1
		13A Single Socket Outlet 13 安培單位電插座	1	1
	Fire Services Pump Room 消防泵房	Lighting Point 燈位	3	3
		Lighting Switch 燈掣	1	1
		Switch for Exhaust Fan 抽氣扇開關掣	1	1
		Fused Spur Unit for Exhaust Fan 接線座連保險絲供抽氣扇	1	1
		Weatherproof Isolator 防水隔離開關掣	3	3
13A Weatherproof Single Socket Outlet 13 安培防水單位電插座		1	1	

Notes:

- "1, 2, ....."denotes the quantity of such provision(s) provided in the residential unit.
- The quantity of the switch & lighting switch shown in the schedule denotes the quantity of switch faceplate.
- "-" means "Not Applicable".

備註:

- "1, 2, ....."表示提供於該住宅單位內的裝置數量。
- 說明表所顯示的開關掣及燈掣數量是表示面板的數量。
- "-"表示「不適用」。

# FITTINGS, FINISHES AND APPLIANCES

## 裝置、裝修物料及設備

### Schedule of Mechanical and Electrical Provisions of Residential Units

#### 住宅單位機電裝置數量說明表

House 1 and House 2

1 號洋房及 2 號洋房

Floor 樓層	Location 位置	Mechanical and Electrical Provisions 機電裝置	House 1 1 號洋房	House 2 2 號洋房
Basement 地庫	Potable Water and Flushing Water Pump Room 食水及沖廁水泵房	Lighting Point 燈位	6	3
		Lighting Switch 燈掣	1	1
		Switch for Exhaust Fan 抽氣扇開關掣	1	1
		Fused Spur Unit for Exhaust Fan 接線座連保險絲供抽氣扇	1	1
		Weatherproof Isolator 防水隔離開關掣	2	3
		13A Weatherproof Single Socket Outlet 13 安培防水單位電插座	1	1
	Lift Lobby 升降機大堂	Door Release Button 開門掣	1	1
		Door Release Break Glass Unit 緊急開門開關	1	1
		Fire Services Break Glass Unit 火警玻璃緊急掣開關	1	1
		Home Automation Lighting Switch 智能家居燈掣	2	-
		Lighting Point 燈位	5	7
		Lighting Switch 燈掣	-	3
		Fused Spur Unit for Indoor Air-conditioner Unit 接線座連保險絲供室內空調機	1	1
		13A Single Socket Outlet 13 安培單位電插座	1	1
		Door Contact 門磁性感應防盜	1	1
		CCTV Camera 閉路電視	1	1
	Parking Space nearby area to Lift Lobby 停車位附近位置往升降機大堂	Fingerprint Door Lock Controller 指紋智能門鎖控制器	1	1
		Videophone Panel 視像對講系統面板	1	1
	Parking Space 停車位	Lighting Point 燈位	3	2
		Electric Vehicle Charging Point 電動車充電位	2	2
		Weatherproof Isolator 防水隔離開關掣	2	2
	Staircase 樓梯	Lighting Point 燈位	2	2

#### Notes:

- "1, 2, ....." denotes the quantity of such provision(s) provided in the residential unit.
- The quantity of the switch & lighting switch shown in the schedule denotes the quantity of switch faceplate.
- "-" means "Not Applicable".

#### 備註:

- "1, 2, ....." 表示提供於該住宅單位內的裝置數量。
- 說明表所顯示的開關掣及燈掣數量是表示面板的數量。
- "-" 表示「不適用」。

# FITTINGS, FINISHES AND APPLIANCES

## 裝置、裝修物料及設備

### Schedule of Mechanical and Electrical Provisions of Residential Units

#### 住宅單位機電裝置數量說明表

House 1 and House 2

1 號洋房及 2 號洋房

Floor 樓層	Location 位置	Mechanical and Electrical Provisions 機電裝置	House 1 1 號洋房	House 2 2 號洋房
Ground Floor 地下	Foyer 玄關	Video Doorphone 視像對講機	-	1
		Lighting Point 燈位	19	14
		Home Automation Lighting Switch 智能家居燈掣	1	-
		Lighting Switch 燈掣	-	3
		Fused Spur Unit for Indoor Air-conditioner Unit 接線座連保險絲供室內空調機	4	2
		13A Single Socket Outlet 13 安培單位電插座	3	1
		Door Contact 門磁性感應防盜	2	1
		Home Automation Control Panel 智能家居系統控制面板	1	-
		Security Control Panel 保安系統控制面板	-	1
	Ground floor main entrance (Entrance gate) 地下主入口 (大閘)	Fingerprint Door Lock Controller 指紋智能門鎖控制器	1	1
		Videophone Panel 視像對講系統面板	1	1
		Door Contact 門磁性感應防盜	1	1
	Staircase 樓梯	Lighting Point 燈位	5	1
		Lighting Switch 燈掣	-	1
	Staircase to Basement 樓梯往地庫	Lighting Point 燈位	3	6
		Fire Services Break Glass Unit 火警玻璃緊急掣開關	1	1
		Home Automation Lighting Switch 智能家居燈掣	1	-
		Lighting Switch 燈掣	-	1
	Living Room 客廳	Lighting Point 燈位	18	14
		Home Automation Lighting Switch and Motorized Curtain Switch 智能家居燈掣及電動窗簾掣	1	-

Notes:

- "1, 2, ....."denotes the quantity of such provision(s) provided in the residential unit.
- The quantity of the switch & lighting switch shown in the schedule denotes the quantity of switch faceplate.
- "-" means "Not Applicable".

備註:

- "1, 2, ....."表示提供於該住宅單位內的裝置數量。
- 說明表所顯示的開關掣及燈掣數量是表示面板的數量。
- "-"表示「不適用」。

# FITTINGS, FINISHES AND APPLIANCES

## 裝置、裝修物料及設備

### Schedule of Mechanical and Electrical Provisions of Residential Units

#### 住宅單位機電裝置數量說明表

House 1 and House 2

1 號洋房及 2 號洋房

Floor 樓層	Location 位置	Mechanical and Electrical Provisions 機電裝置	House 1 1 號洋房	House 2 2 號洋房
Ground Floor 地下	Living Room 客廳	TV/FM Outlet 電視及電台天線插座	1	2
		Data Outlet 上網插座	1	1
		13A Twin Socket Outlet 13 安培雙位電插座	1	4
		Fused Spur Unit for Indoor Air-conditioner Unit 接線座連保險絲供室內空調機	1	2
		Panic Alarm Button 緊急警報按鈕	1	1
		Door Contact 門磁性感應防盜	1	1
		Glass Break Detector 玻璃破碎感應器	1	2
	Dining Room 飯廳	Lighting Point 燈位	27	20
		Home Automation Lighting Switch and Motorized Curtain Switch 智能家居燈掣及電動窗簾掣	1	-
		Home Automation Lighting Switch 智能家居燈掣	1	-
		Lighting Switch 燈掣	-	2
		Façade Lighting Switch 外牆燈掣	-	1
		TV/FM Outlet 電視及電台天線插座	-	1
		Data Outlet 上網插座	-	1
		13A Single Socket Outlet 13 安培單位電插座	2	-
		13A Twin Socket Outlet 13 安培雙位電插座	1	3
		Fused Spur Unit for Indoor Air-conditioner Unit 接線座連保險絲供室內空調機	2	2
		13A Single Socket Outlet for Fully Integrated Fridge - Freezer 13 安培單位電插座供嵌入式雪櫃	1	1
		13A Single Socket Outlet for Built-in Wine Cellar 13 安培單位電插座供嵌入式酒櫃	1	1
		13A Single Socket Outlet for Induction Hob 13 安培單位電插座供嵌入式電磁爐	1	1
		Door Contact 門磁性感應防盜	1	1
		Glass Break Detector 玻璃破碎感應器	1	2

#### Notes:

- "1, 2, ....." denotes the quantity of such provision(s) provided in the residential unit.
- The quantity of the switch & lighting switch shown in the schedule denotes the quantity of switch faceplate.
- "-" means "Not Applicable".

#### 備註:

- "1, 2, ....." 表示提供於該住宅單位內的裝置數量。
- 說明表所顯示的開關掣及燈掣數量是表示面板的數量。
- "-" 表示「不適用」。

# FITTINGS, FINISHES AND APPLIANCES

## 裝置、裝修物料及設備

### Schedule of Mechanical and Electrical Provisions of Residential Units

#### 住宅單位機電裝置數量說明表

House 1 and House 2

1 號洋房及 2 號洋房

Floor 樓層	Location 位置	Mechanical and Electrical Provisions 機電裝置	House 1 1 號洋房	House 2 2 號洋房
Ground Floor 地下	Kitchen 廚房	Lighting Point 燈位	10	9
		Lighting Switch 燈掣	1	1
		Switch for Exhaust Fan 抽氣扇開關掣	1	1
		Fused Spur Unit for Indoor Air-conditioner Unit 接線座連保險絲供室內空調機	2	2
		Fused Spur Unit for Exhaust Fan 接線座連保險絲供抽氣扇	1	1
		Towngas Hot Water Control Unit 煤氣熱水控制器	1	1
		13A Twin Socket Outlet 13 安培雙位電插座	6	3
		Washing Machine Connection Point (Water Inlet) 洗衣機接駁點 (來水位)	1	1
		Washing Machine Connection Point (Water Outlet) 洗衣機接駁點 (去水位)	1	1
		13A Single Socket Outlet for Built-in Dishwasher 13 安培單位電插座供嵌入式洗碗碟機	1	1
		Fused Spur Unit for Cooker Hood 保險絲電源接線座供抽油煙機	1	1
		Fused Spur Unit for Built-in Double Gas Burner 保險絲電源接線座供嵌入式煤氣雙頭煮食爐	1	1
		Fused Spur Unit for Induction Hob 保險絲電源接線座供嵌入式電磁爐	1	1
		Fused Spur Unit for Built-in Gas Burner 保險絲電源接線座供嵌入式煤氣煮食爐	1	1
		13A Single Socket Outlet for Built-in Microwave Oven 13 安培單位電插座供嵌入式微波爐	1	1
		13A Single Socket Outlet for Built-in Oven 13 安培單位電插座供嵌入式焗爐	1	1
		13A Single Socket Outlet for Built-in Steam Oven 13 安培單位電插座供嵌入式蒸爐	1	1
		13A Single Socket Outlet for Built-in Fridge - Freezer 13 安培單位電插座供嵌入式雪櫃	2	2
		13A Single Socket Outlet for Freestanding Washing Machine 13 安培單位電插座供獨立式洗衣機	1	1
		13A Single Socket Outlet for Freestanding Dryer 13 安培單位電插座供獨立式乾衣機	1	1
Window Contact 窗磁性感應防盜	2	2		
Door Contact 門磁性感應防盜	1	1		
CCTV Monitor 閉路電視顯示屏	1	1		

Notes:

- "1, 2, ....."denotes the quantity of such provision(s) provided in the residential unit.
- The quantity of the switch & lighting switch shown in the schedule denotes the quantity of switch faceplate.
- "-" means "Not Applicable".

備註:

- "1, 2, ....."表示提供於該住宅單位內的裝置數量。
- 說明表所顯示的開關掣及燈掣數量是表示面板的數量。
- "-"表示「不適用」。

# FITTINGS, FINISHES AND APPLIANCES

## 裝置、裝修物料及設備

### Schedule of Mechanical and Electrical Provisions of Residential Units

#### 住宅單位機電裝置數量說明表

House 1 and House 2

1 號洋房及 2 號洋房

Floor 樓層	Location 位置	Mechanical and Electrical Provisions 機電裝置	House 1 1 號洋房	House 2 2 號洋房
Ground Floor 地下	Library 圖書房	Lighting Point 燈位	7	6
		Home Automation Lighting Switch and Motorized Curtain Switch 智能家居燈掣及電動窗簾掣	1	-
		Lighting Switch 燈掣	-	1
		Fused Connection Unit 保險絲接線座	1	-
		Fused Spur Unit for Indoor Air-conditioner Unit 接線座連保險絲供室內空調機	1	1
		13A Single Socket Outlet 13 安培單位電插座	2	-
		13A Twin Socket Outlet 13 安培雙位電插座	-	3
		Door Contact 門磁性感應防盜	1	-
		Window Contact 窗磁性感應防盜	2	2
		Glass Break Detector 玻璃破碎感應器	1	-
	Bathroom 7 浴室 7	Lighting Point 燈位	10	-
		Home Automation Lighting Switch 智能家居燈掣	1	-
		Switch for Thermo Ventilator 浴室換氣暖風機開關掣	1	-
		Fused Spur Unit ( Occupied by appliances) 保險絲電源接線座 (已連接有關設備)	1	-
		Towngas Hot Water Control Unit 煤氣熱水控制器	1	-
	Lavatory 洗手間	Lighting Point 燈位	-	5
		Lighting Switch 燈掣	-	1
		Switch for Exhaust Fan 抽氣扇開關掣	-	1
		Fused Spur Unit for Exhaust Fan 接線座連保險絲供抽氣扇	-	2
		Shaver Socket Outlet 鬚刨插座	-	1
		Towngas Hot Water Control Unit 煤氣熱水控制器	-	1

**Notes:**

- "1, 2, ....." denotes the quantity of such provision(s) provided in the residential unit.
- The quantity of the switch & lighting switch shown in the schedule denotes the quantity of switch faceplate.
- "-" means "Not Applicable".

**備註:**

- "1, 2, ....." 表示提供於該住宅單位內的裝置數量。
- 說明表所顯示的開關掣及燈掣數量是表示面板的數量。
- "-" 表示「不適用」。

# FITTINGS, FINISHES AND APPLIANCES

## 裝置、裝修物料及設備

### Schedule of Mechanical and Electrical Provisions of Residential Units

#### 住宅單位機電裝置數量說明表

House 1 and House 2

1 號洋房及 2 號洋房

Floor 樓層	Location 位置	Mechanical and Electrical Provisions 機電裝置	House 1 1 號洋房	House 2 2 號洋房
Ground Floor 地下	Store Room 儲物房	Lighting Point 燈位	-	2
		Lighting Switch 燈掣	-	1
		13A Twin Socket Outlet 13 安培雙位電插座	-	1
	Store Room under Staircase 儲物房 (樓梯底)	Lighting Point 燈位	-	1
		Lighting Switch 燈掣	-	1
	Garden 花園	Door Release Button 開門掣	1	1
		Door Release Break Glass Unit 緊急開門開關	1	1
		Fingerprint Door Lock Controller 指紋智能門鎖控制器	2	2
		Lighting Point 燈位	36	21
		13A Weatherproof Single Socket Outlet 13 安培防水單位電插座	7	5
		CCTV Camera 閉路電視	7	5
	First Floor 一樓	Staircase 樓梯	Lighting Point 燈位	4
Lighting Switch 燈掣			-	2
Corridor 走廊		Lighting Point 燈位	13	9
		Lighting Switch 燈掣	-	2
		Home Automation Lighting Switch 智能家居燈掣	4	-
		Fused Spur Unit for Indoor Air-conditioner Unit 接線座連保險絲供室內空調機	2	2
		13A Single Socket Outlet 13 安培單位電插座	1	1

Notes:

- "1, 2, ....."denotes the quantity of such provision(s) provided in the residential unit.
- The quantity of the switch & lighting switch shown in the schedule denotes the quantity of switch faceplate.
- "-" means "Not Applicable".

備註:

- "1, 2, ....."表示提供於該住宅單位內的裝置數量。
- 說明表所顯示的開關掣及燈掣數量是表示面板的數量。
- "-"表示「不適用」。

# FITTINGS, FINISHES AND APPLIANCES

## 裝置、裝修物料及設備

### Schedule of Mechanical and Electrical Provisions of Residential Units

#### 住宅單位機電裝置數量說明表

House 1 and House 2

1 號洋房及 2 號洋房

Floor 樓層	Location 位置	Mechanical and Electrical Provisions 機電裝置	House 1 1 號洋房	House 2 2 號洋房
First Floor 一樓	Family Room 家庭廳	Video Doorphone 視像對講機	-	1
		Lighting Point 燈位	11	12
		Home Automation Lighting Switch and Motorized Curtain Switch 智能家居燈掣及電動窗簾掣	1	-
		Lighting Switch 燈掣	-	1
		Balcony Lighting Switch 露台燈掣	-	1
		TV/FM Outlet 電視及電台天線插座	1	1
		Data Outlet 上網插座	-	1
		Fused Spur Unit for Indoor Air-conditioner Unit 接線座連保險絲供室內空調機	-	2
		13A Single Socket Outlet 13 安培單位電插座	1	-
		13A Twin Socket Outlet 13 安培雙位電插座	1	3
		Panic Alarm Button 緊急警報按鈕	1	1
		Window Contact 窗磁性感應防盜	-	2
		Door Contact 門磁性感應防盜	1	1
		Glass Break Detector 玻璃破碎感應器	1	1
	Game Room 遊戲房	Lighting Point 燈位	8	-
		Home Automation Lighting Switch and Motorized Curtain Switch 智能家居燈掣及電動窗簾掣	1	-
		TV/FM Outlet 電視及電台天線插座	1	-
		13A Single Socket Outlet 13 安培單位電插座	1	-
		13A Twin Socket Outlet 13 安培雙位電插座	1	-
		Window Contact 窗磁性感應防盜	2	-
		Glass Break Detector 玻璃破碎感應器	1	-

**Notes:**

- "1, 2, ....." denotes the quantity of such provision(s) provided in the residential unit.
- The quantity of the switch & lighting switch shown in the schedule denotes the quantity of switch faceplate.
- "-" means "Not Applicable".

**備註:**

- "1, 2, ....." 表示提供於該住宅單位內的裝置數量。
- 說明表所顯示的開關掣及燈掣數量是表示面板的數量。
- "-" 表示「不適用」。

# FITTINGS, FINISHES AND APPLIANCES

## 裝置、裝修物料及設備

### Schedule of Mechanical and Electrical Provisions of Residential Units

#### 住宅單位機電裝置數量說明表

House 1 and House 2

1 號洋房及 2 號洋房

Floor 樓層	Location 位置	Mechanical and Electrical Provisions 機電裝置	House 1 1 號洋房	House 2 2 號洋房
First Floor 一樓	Bedroom 3 睡房 3	Lighting Point 燈位	13	11
		Home Automation Lighting Switch and Motorized Curtain Switch 智能家居燈掣及電動窗簾掣	4	-
		Lighting Switch 燈掣	-	1
		Utility Platform Lighting Switch 工作平台燈掣	-	1
		Home Automation Control Panel 智能家居系統控制面板	1	-
		TV/FM Outlet 電視及電台天線插座	1	1
		Data Outlet 上網插座	2	1
		Fused Spur Unit for Indoor Air-conditioner Unit 接線座連保險絲供室內空調機	2	2
		Fused Spur Unit for Lamp 接線座連保險絲供燈具	2	-
		13A Single Socket Outlet 13 安培單位電插座	2	-
		13A Twin Socket Outlet 13 安培雙位電插座	3	3
		Glass Break Detector 玻璃破碎感應器	1	2
		Window Contact 窗磁性感應防盜	2	2
		Door Contact 門磁性感應防盜	1	1
Panic Alarm Button 緊急警報按鈕	1	-		

#### Notes:

- "1, 2, ....."denotes the quantity of such provision(s) provided in the residential unit.
- The quantity of the switch & lighting switch shown in the schedule denotes the quantity of switch faceplate.
- "-" means "Not Applicable"..

#### 備註:

- "1, 2, ....."表示提供於該住宅單位內的裝置數量。
- 說明表所顯示的開關掣及燈掣數量是表示面板的數量。
- "-"表示「不適用」。

## FITTINGS, FINISHES AND APPLIANCES 裝置、裝修物料及設備

### Schedule of Mechanical and Electrical Provisions of Residential Units

#### 住宅單位機電裝置數量說明表

House 1 and House 2

1 號洋房及 2 號洋房

Floor 樓層	Location 位置	Mechanical and Electrical Provisions 機電裝置	House 1 1 號洋房	House 2 2 號洋房
First Floor 一樓	Bedroom 4 睡房 4	Lighting Point 燈位	8	9
		Home Automation Lighting Switch and Motorized Curtain Switch 智能家居燈掣及電動窗簾掣	3	-
		Lighting Switch 燈掣	-	1
		TV/FM Outlet 電視及電台天線插座	1	1
		Data Outlet 上網插座	3	1
		Fused Spur Unit for Indoor Air-conditioner Unit 接線座連保險絲供室內空調機	1	1
		Fused Spur Unit for Lamp 接線座連保險絲供燈具	2	-
		13A Single Socket Outlet 13 安培單位電插座	2	-
		13A Twin Socket Outlet 13 安培雙位電插座	3	2
		Window Contact 窗磁性感應防盜	2	2
		Glass Break Detector 玻璃破碎感應器	1	1
		Panic Alarm Button 緊急警報按鈕	-	1
	Bathroom 4 浴室 4	Lighting Point 燈位	9	8
		Lighting Switch 燈掣	-	1
		Switch for Exhaust Fan 抽氣扇開關掣	-	1
		Data Outlet 上網插座	1	1
		Shaver Socket Outlet 鬚刨插座	1	1
		TV/FM Outlet 電視及電台天線插座	1	1
		13A Single Socket Outlet (Occupied by appliances) 13 安培單位電插座 (已連接有關設備)	1	1
		Fused Spur Unit for Exhaust Fan 接線座連保險絲供抽氣扇	1	2
		Fused Spur Unit (Occupied by appliances) 接線座連保險絲 (已連接有關設備)	2	2
		Towngas Hot Water Control Unit 煤氣熱水控制器	1	1
Floor Heat System Controller 地熱系統控制器	-	1		

Notes:

- "1, 2, ....." denotes the quantity of such provision(s) provided in the residential unit.
- The quantity of the switch & lighting switch shown in the schedule denotes the quantity of switch faceplate.
- "-" means "Not Applicable".

備註:

- "1, 2, ....." 表示提供於該住宅單位內的裝置數量。
- 說明表所顯示的開關掣及燈掣數量是表示面板的數量。
- "-" 表示「不適用」。

# FITTINGS, FINISHES AND APPLIANCES

## 裝置、裝修物料及設備

### Schedule of Mechanical and Electrical Provisions of Residential Units

#### 住宅單位機電裝置數量說明表

House 1 and House 2

1 號洋房及 2 號洋房

Floor 樓層	Location 位置	Mechanical and Electrical Provisions 機電裝置	House 1 1 號洋房	House 2 2 號洋房
First Floor 一樓	Walk-in Closet (Bathroom 4) 衣帽間 (浴室 4)	Lighting Point 燈位	2	2
		Home Automation Lighting Switch 智能家居燈掣	1	-
		Switch for Exhaust Fan 抽氣扇開關掣	1	-
		Fused Spur Unit for Indoor Air-conditioner Unit 接線座連保險絲供室內空調機	1	1
		13A Single Socket Outlet 13 安培單位電插座	1	-
		Floor Heat System Controller 地熱系統控制器	1	-
	Walk-in Closet (Near Bathroom 5) (For House 2) 衣帽間 (近浴室 5) (2 號洋房)	Lighting Point 燈位	-	3
		Fused Spur Unit for Indoor Air-conditioner Unit 接線座連保險絲供室內空調機	-	1
		13A Twin Socket Outlet 13 安培雙位電插座	-	1
	Bathroom 5 浴室 5	Lighting Point 燈位	7	6
		Home Automation Lighting Switch 智能家居燈掣	1	-
		Lighting Switch 燈掣	-	1
		Switch for Thermo Ventilator 浴室換氣暖風機開關掣	1	-
		Switch for Exhaust Fan 抽氣扇開關掣	-	1
		Fused Spur Unit (Occupied by appliances) 接線座連保險絲 (已連接有關設備)	1	1
		Fused Spur Unit for Exhaust Fan 接線座連保險絲供抽氣扇	-	1
		Shaver Socket Outlet 鬚刨插座	1	1
		Floor Heat System Controller 地熱系統控制器	1	1
		Window Contact 窗磁性感應防盜	1	2
		Towngas Hot Water Control Unit 煤氣熱水控制器	1	1

Notes:

- "1, 2, ....."denotes the quantity of such provision(s) provided in the residential unit.
- The quantity of the switch & lighting switch shown in the schedule denotes the quantity of switch faceplate.
- "-" means "Not Applicable"..

備註:

- "1, 2, ....."表示提供於該住宅單位內的裝置數量。
- 說明表所顯示的開關掣及燈掣數量是表示面板的數量。
- "-"表示「不適用」。

# FITTINGS, FINISHES AND APPLIANCES

## 裝置、裝修物料及設備

### Schedule of Mechanical and Electrical Provisions of Residential Units

#### 住宅單位機電裝置數量說明表

House 1 and House 2

1 號洋房及 2 號洋房

Floor 樓層	Location 位置	Mechanical and Electrical Provisions 機電裝置	House 1 1 號洋房	House 2 2 號洋房
First Floor 一樓	Bathroom 6 浴室 6	Lighting Point 燈位	6	-
		Home Automation Lighting Switch 智能家居燈掣	1	-
		Switch for Thermo Ventilator 浴室換氣暖風機開關掣	1	-
		Fused Spur Unit (Occupied by appliances) 接線座連保險絲 (已連接有關設備)	1	-
		Fused Spur Unit for Indoor Air-conditioner Unit 接線座連保險絲供室內空調機	1	-
		Shaver Socket Outlet 鬚刨插座	1	-
		Window Contact 窗磁性感應防盜	1	-
		Towngas Hot Water Control Unit 煤氣熱水控制器	1	-
	Utility Room 工作間	Lighting Point 燈位	6	10
		Lighting Switch 燈掣	2	2
		Switch for Exhaust Fan 抽氣扇開關掣	1	1
		TV/FM Outlet 電視及電台天線插座	1	1
		Home Automation Control Panel 智能家居系統控制面板	1	-
		Data Outlet 上網插座	-	1
		Fused Spur Unit for Indoor Air-conditioner Unit 接線座連保險絲供室內空調機	1	1
		13A Twin Socket Outlet 13 安培雙位電插座	4	3
		MCCB Distribution Board 塑型斷路器配電箱	1	-
		Towngas Hot Water Control Unit 煤氣熱水控制器	1	-
		Lift Control Panel 電梯控制面板	1	1
		Air Conditioning Main Control Unit 空氣調節中央控制器	1	1
		Panic Alarm Button 緊急警報按鈕	1	1
		Window Contact 窗磁性感應防盜	2	2
		Glass Break Detector 玻璃破碎感應器	1	1

**Notes:**

- "1, 2, ....." denotes the quantity of such provision(s) provided in the residential unit.
- The quantity of the switch & lighting switch shown in the schedule denotes the quantity of switch faceplate.
- "-" means "Not Applicable".

**備註:**

- "1, 2, ....." 表示提供於該住宅單位內的裝置數量。
- 說明表所顯示的開關掣及燈掣數量是表示面板的數量。
- "-" 表示「不適用」。

# FITTINGS, FINISHES AND APPLIANCES

## 裝置、裝修物料及設備

### Schedule of Mechanical and Electrical Provisions of Residential Units

#### 住宅單位機電裝置數量說明表

House 1 and House 2

1 號洋房及 2 號洋房

Floor 樓層	Location 位置	Mechanical and Electrical Provisions 機電裝置	House 1 1 號洋房	House 2 2 號洋房
First Floor 一樓	Lavatory 洗手間	Lighting Point 燈位	2	1
		Fused Spur Unit for Exhaust Fan 接線座連保險絲供抽氣扇	1	2
		Towngas Hot Water Control Unit 煤氣熱水控制器	-	1
	Store Room 儲物房	Lighting Point 燈位	4	1
		Lighting Switch 燈掣	-	1
		Fused Spur Unit for Indoor Air-conditioner Unit 接線座連保險絲供室內空調機	1	-
		Fused Spur Unit for Exhaust Fan 接線座連保險絲供抽氣扇	1	-
		13A Single Socket Outlet 13 安培單位電插座	1	1
		13A Twin Socket Outlet 13 安培雙位電插座	2	-
		13A Single Socket Outlet for Built-in Microwave Oven 13 安培單位電插座供嵌入式微波爐	1	-
		13A Single Socket Outlet for Built-under Wine Cellar 13 安培單位電插座供嵌入式酒櫃	1	-
		13A Single Socket Outlet for Coffee Maker 13 安培單位電插座供嵌入式咖啡機	1	-
		13A Single Socket Outlet for Built-under Refrigerator 13 安培單位電插座供嵌入式雪櫃	1	-
		Window Contact 窗磁性感應防盜	1	-
	Glass Break Detector 玻璃破碎感應器	1	-	
	Utility Platform 工作平台	Lighting Point 燈位	1	1
	Balcony 露台	Lighting Point 燈位	-	1
Flat Roof 平台	Lighting Point 燈位	1	-	

Notes:

- "1, 2, ....."denotes the quantity of such provision(s) provided in the residential unit.
- The quantity of the switch & lighting switch shown in the schedule denotes the quantity of switch faceplate.
- "-" means "Not Applicable"..

備註:

- "1, 2, ....."表示提供於該住宅單位內的裝置數量。
- 說明表所顯示的開關掣及燈掣數量是表示面板的數量。
- "-"表示「不適用」。

# FITTINGS, FINISHES AND APPLIANCES

## 裝置、裝修物料及設備

### Schedule of Mechanical and Electrical Provisions of Residential Units

#### 住宅單位機電裝置數量說明表

House 1 and House 2

1 號洋房及 2 號洋房

Floor 樓層	Location 位置	Mechanical and Electrical Provisions 機電裝置	House 1 1 號洋房	House 2 2 號洋房
Second Floor 二樓	Staircase 樓梯	Lighting Point 燈位	4	1
		Glass Break Detector 玻璃破碎感應器	-	1
	Corridor 走廊	Lighting Point 燈位	14	9
		Home Automation Lighting Switch 智能家居燈掣	2	-
		Lighting Switch 燈掣	-	4
		Fused Spur Unit for Indoor Air-conditioner Unit 接線座連保險絲供室內空調機	2	1
		13A Twin Socket Outlet 13 安培雙位電插座	1	-
		13A Single Socket Outlet for Built-in Microwave Oven 13 安培單位電插座供嵌入式微波爐	1	-
		13A Single Socket Outlet for Built-under Wine Cellar 13 安培單位電插座供嵌入式酒櫃	1	-
		13A Single Socket Outlet for Coffee Maker 13 安培單位電插座供嵌入式咖啡機	1	-
		13A Single Socket Outlet for Built-under Refrigerator 13 安培單位電插座供嵌入式雪櫃	1	-
		Window Contact 窗磁性感應防盜	1	-
	Glass Break Detector 玻璃破碎感應器	1	-	
	Fitness Room (For House 1) 健身房 (1 號洋房)	Lighting Point 燈位	3	-
		Home Automation Lighting Switch and Motorized Curtain Switch 智能家居燈掣及電動窗簾掣	1	-
		Fused Spur Unit for Indoor Air-conditioner Unit 接線座連保險絲供室內空調機	1	-
		13A Single Socket Outlet 13 安培單位電插座	1	-
		13A Twin Socket Outlet 13 安培雙位電插座	1	-
		Panic Alarm Button 緊急警報按鈕	1	-
		Window Contact 窗磁性感應防盜	2	-
		Glass Break Detector 玻璃破碎感應器	1	-
	Master Bedroom 主人睡房	Lighting Point 燈位	25	21
		Home Automation Lighting Switch and Motorized Curtain Switch 智能家居燈掣及電動窗簾掣	3	-
Lighting Switch 燈掣		-	1	

**Notes:**

- "1, 2, ....." denotes the quantity of such provision(s) provided in the residential unit.
- The quantity of the switch & lighting switch shown in the schedule denotes the quantity of switch faceplate.
- "-" means "Not Applicable".

**備註:**

- "1, 2, ....." 表示提供於該住宅單位內的裝置數量。
- 說明表所顯示的開關掣及燈掣數量是表示面板的數量。
- "-" 表示「不適用」。

# FITTINGS, FINISHES AND APPLIANCES

## 裝置、裝修物料及設備

### Schedule of Mechanical and Electrical Provisions of Residential Units

#### 住宅單位機電裝置數量說明表

House 1 and House 2

1 號洋房及 2 號洋房

Floor 樓層	Location 位置	Mechanical and Electrical Provisions 機電裝置	House 1 1 號洋房	House 2 2 號洋房
Second Floor 二樓	Master Bedroom 主人睡房	Home Automation Control Panel 智能家居系統控制面板	1	-
		TV/FM Outlet 電視及電台天線插座	1	-
		Data Outlet 上網插座	2	-
		Fused Spur Unit for Exhaust Fan 接線座連保險絲供抽氣扇	1	-
		Fused Spur Unit for Indoor Air-conditioner Unit 接線座連保險絲供室內空調機	1	3
		Fused Spur Unit for Lamp 接線座連保險絲供燈具	3	-
		13A Single Socket Outlet 13 安培單位電插座	4	1
		13A Twin Socket Outlet 13 安培雙位電插座	3	3
		Panic Alarm Button 緊急警報按鈕	1	-
		Window Contact 窗磁性感應防盜	2	3
		Door Contact 門磁性感應防盜	1	1
	Glass Break Detector 玻璃破碎感應器	1	3	
	Bedroom 2 睡房 2	Lighting Point 燈位	12	9
		Home Automation Lighting Switch and Motorized Curtain Switch 智能家居燈掣及電動窗簾掣	1	-
		Lighting Switch 燈掣	-	1
		Fused Spur Unit for Lamp 接線座連保險絲供燈具	2	-
		Fused Spur Unit for Indoor Air-conditioner Unit 接線座連保險絲供室內空調機	1	1
		TV/FM Outlet 電視及電台天線插座	1	1
		Data Outlet 上網插座	1	1
		13A Twin Socket Outlet 13 安培雙位電插座	3	2
Panic Alarm Button 緊急警報按鈕		-	1	
Window Contact 窗磁性感應防盜	2	2		
Glass Break Detector 玻璃破碎感應器	1	1		

**Notes:**

- "1, 2, ....."denotes the quantity of such provision(s) provided in the residential unit.
- The quantity of the switch & lighting switch shown in the schedule denotes the quantity of switch faceplate.
- "-" means "Not Applicable"..

**備註:**

- "1, 2, ....."表示提供於該住宅單位內的裝置數量。
- 說明表所顯示的開關掣及燈掣數量是表示面板的數量。
- "-"表示「不適用」。

# FITTINGS, FINISHES AND APPLIANCES

## 裝置、裝修物料及設備

### Schedule of Mechanical and Electrical Provisions of Residential Units

#### 住宅單位機電裝置數量說明表

House 1 and House 2

1 號洋房及 2 號洋房

Floor 樓層	Location 位置	Mechanical and Electrical Provisions 機電裝置	House 1 1 號洋房	House 2 2 號洋房
Second Floor 二樓	Walk-in Closet (Bathroom 1) 衣帽間 (浴室 1)	Lighting Point 燈位	3	8
		Lighting Switch 燈掣	-	1
		Switch for Exhaust Fan 抽氣扇開關掣	1	-
		Fused Spur Unit for Exhaust Fan 接線座連保險絲供抽氣扇	-	1
		Fused Spur Unit for Indoor Air-conditioner Unit 接線座連保險絲供室內空調機	-	2
		Fused Spur Unit (Occupied by appliances) 保險絲電源接線座 (已連接有關設備)	-	1
		13A Single Socket Outlet 13 安培單位電插座	1	-
	Bathroom 1 浴室 1	Lighting Point 燈位	11	11
		Home Automation Lighting Switch 智能家居燈掣	1	-
		Lighting Switch 燈掣	-	1
		Switch for Exhaust Fan 抽氣扇開關掣	-	1
		Fused Spur Unit for Exhaust Fan 接線座連保險絲供抽氣扇	1	1
		Fused Spur Unit for Indoor Air-conditioner Unit 接線座連保險絲供室內空調機	1	1
		Data Outlet 上網插座	1	1
		TV/FM Outlet 電視及電台天線插座	1	1
		Shaver Socket Outlet 鬚刨插座	1	1
		13A Single Socket Outlet (Occupied by appliances) 13 安培單位電插座 (已連接有關設備)	1	1
		Floor Heat System Controller 地熱系統控制器	1	1
		Window Contact 窗磁性感應防盜	2	2
		Towngas Hot Water Control Unit 煤氣熱水控制器	1	1

Notes:

- "1, 2, ....." denotes the quantity of such provision(s) provided in the residential unit.
- The quantity of the switch & lighting switch shown in the schedule denotes the quantity of switch faceplate.
- "-" means "Not Applicable".

備註:

- "1, 2, ....." 表示提供於該住宅單位內的裝置數量。
- 說明表所顯示的開關掣及燈掣數量是表示面板的數量。
- "-" 表示「不適用」。

# FITTINGS, FINISHES AND APPLIANCES

## 裝置、裝修物料及設備

### Schedule of Mechanical and Electrical Provisions of Residential Units

#### 住宅單位機電裝置數量說明表

House 1 and House 2

1 號洋房及 2 號洋房

Floor 樓層	Location 位置	Mechanical and Electrical Provisions 機電裝置	House 1 1 號洋房	House 2 2 號洋房
Second Floor 二樓	Bathroom 2 浴室 2	Lighting Point 燈位	20	11
		Home Automation Lighting Switch 智能家居燈掣	1	-
		Lighting Switch 燈掣	-	1
		Switch for Exhaust Fan 抽氣扇開關掣	1	1
		Data Outlet 上網插座	1	1
		Fused Spur Unit for Indoor Air-conditioner Unit 接線座連保險絲供室內空調機	1	1
		Fused Spur Unit for Exhaust Fan 接線座連保險絲供抽氣扇	1	1
		TV/FM Outlet 電視及電台天線插座	1	1
		Shaver Socket Outlet 鬚刨插座	1	1
		13A Single Socket Outlet (Occupied by appliances) 13 安培單位電插座 (已連接有關設備)	1	1
		Floor Heat System Controller 地熱系統控制器	1	1
		Window Contact 窗磁性感應防盜	2	2
	Towngas Hot Water Control Unit 煤氣熱水控制器	1	1	
	Bathroom 3 浴室 3	Lighting Point 燈位	7	8
		Home Automation Lighting Switch 智能家居燈掣	1	-
		Lighting Switch 燈掣	-	1
		Switch for Exhaust Fan 抽氣扇開關掣	-	1
		Switch for Thermo Ventilator 浴室換氣暖風機開關掣	1	-
		Fused Spur Unit (Occupied by appliances) 保險絲電源接線座 (已連接有關設備)	1	-
		Fused Spur Unit for Exhaust Fan 接線座連保險絲供抽氣扇	-	1
		Fused Spur Unit for Indoor Air-conditioner Unit 接線座連保險絲供室內空調機	1	1
		Shaver Socket Outlet 鬚刨插座	1	1
		Floor Heat System Controller 地熱系統控制器	1	1
		Window Contact 窗磁性感應防盜	1	2
Towngas Hot Water Control Unit 煤氣熱水控制器		1	1	

Notes:

- "1, 2, ....."denotes the quantity of such provision(s) provided in the residential unit.
- The quantity of the switch & lighting switch shown in the schedule denotes the quantity of switch faceplate.
- "-" means "Not Applicable"..

備註:

- "1, 2, ....."表示提供於該住宅單位內的裝置數量。
- 說明表所顯示的開關掣及燈掣數量是表示面板的數量。
- "-"表示「不適用」。

# FITTINGS, FINISHES AND APPLIANCES

## 裝置、裝修物料及設備

### Schedule of Mechanical and Electrical Provisions of Residential Units

#### 住宅單位機電裝置數量說明表

House 1 and House 2

1 號洋房及 2 號洋房

Floor 樓層	Location 位置	Mechanical and Electrical Provisions 機電裝置	House 1 1 號洋房	House 2 2 號洋房
Second Floor 二樓	Store Room 儲物房	Lighting Point 燈位	4	2
		Lighting Switch 燈掣	1	1
		Switch for Exhaust Fan 抽氣扇開關掣	1	1
		Data Outlet 上網插座	1	1
		Fused Spur Unit for Exhaust Fan 接線座連保險絲供抽氣扇	-	1
		Fused Spur Unit for Indoor Air-conditioner Unit 接線座連保險絲供室內空調機	1	1
		13A Single Socket Outlet 13 安培單位電插座	2	2
	Panic Alarm Button 緊急警報按鈕	1	1	
Balcony 露台	Lighting Point 燈位	1	-	
Roof 天台	Roof 天台	CCTV Camera 閉路電視	3	4
		Lighting Point 燈位	17	9
		Weatherproof Isolator 防水隔離開關掣	1	1
		Weatherproof Isolator for Outdoor Air-conditioner Unit 室外冷氣機防水隔離開關掣	6	6
		13A Weatherproof Single Socket Outlet 13 安培防水單位電插座	5	4
	Staircase 樓梯	Glass Break Detector 玻璃破碎感應器	2	1
		Fused Spur Unit for Indoor Air-conditioner Unit 接線座連保險絲供室內空調機	2	1
		Fire Services Break Glass Unit 火警玻璃緊急掣開關	1	1
		Door Contact 門磁性感應防盜	1	1
		13A Single Socket Outlet 13 安培單位電插座	2	-
		Lighting Point 燈位	2	4
		Lighting Switch 燈掣	1	2

#### Notes:

- "1, 2, ....." denotes the quantity of such provision(s) provided in the residential unit.
- The quantity of the switch & lighting switch shown in the schedule denotes the quantity of switch faceplate.
- "-" means "Not Applicable".

#### 備註:

- "1, 2, ....." 表示提供於該住宅單位內的裝置數量。
- 說明表所顯示的開關掣及燈掣數量是表示面板的數量。
- "-" 表示「不適用」。

## SERVICE AGREEMENTS 服務協議

---

Potable and flushing water is supplied by Water Supplies Department.  
Electricity is supplied by CLP Power Hong Kong Limited.  
Towngas is supplied by The Hong Kong and China Gas Company Limited.

食水及沖廁水由水務署供應。  
電力由中華電力有限公司供應。  
煤氣由香港中華煤氣有限公司供應。

## GOVERNMENT RENT 地稅

---

The vendor will pay or has paid (as the case may be) all outstanding Government Rent in respect of the specified residential properties from the date of the Government Grant up to and including the date of the respective assignments of the specified residential properties to the purchasers.

賣方將會或已經(視屬何情況而定)繳付指明住宅物業由批地文件之日期起計直至相關指明住宅物業買方之轉讓契日期(包括該日)之地稅。

## MISCELLANEOUS PAYMENTS BY PURCHASER 買方的雜項付款

---

1. On delivery of the vacant possession of the residential property to the purchaser, the purchaser is liable to reimburse the Owner for the deposits for water, electricity and gas; and
2. On the delivery, the purchaser is not liable to pay to the Owner a debris removal fee.

Note: On that delivery, the purchaser is liable to pay a debris removal fee to the manager (not the owner) of the Development under the deed of the mutual covenant, and where the owner has paid that debris removal fee, the purchaser shall reimburse the owner for the same.

1. 在向買方交付住宅物業在空置情況下的管有權時，買方須負責向擁有人補還水、電力及氣體的按金；及
2. 在交付時，買方不須向擁有人支付清理廢料的費用。

備註：在交付時，買方須根據公契向發展項目的管理人(而非擁有人)支付清理廢料的費用，而如擁有人已支付清理廢料的費用，買方須向擁有人補還清理廢料的費用。

## DEFECT LIABILITY WARRANTY PERIOD 欠妥之處的保養責任期

---

The vendor shall, at its own cost and as soon as reasonably practicable after receipt of a written notice served by the purchaser within 6 months after the date of completion of the sale and purchase of the residential property, remedy any defects to that property, or the fittings, finishes or appliances incorporated into the property as set out in the agreement for sale and purchase concerned, caused otherwise than by the act or neglect of the purchaser.

凡物業或於買賣合約列出裝設於物業內的裝置、裝修物料或設備有欠妥之處，而該欠妥之處並非由買方行為或疏忽造成，則賣方在接獲買方在買賣成交日期後的6個月內送達的書面通知後，須於合理地切實可行的範圍內盡快自費作出補救。

# MAINTENANCE OF SLOPES 斜坡維修

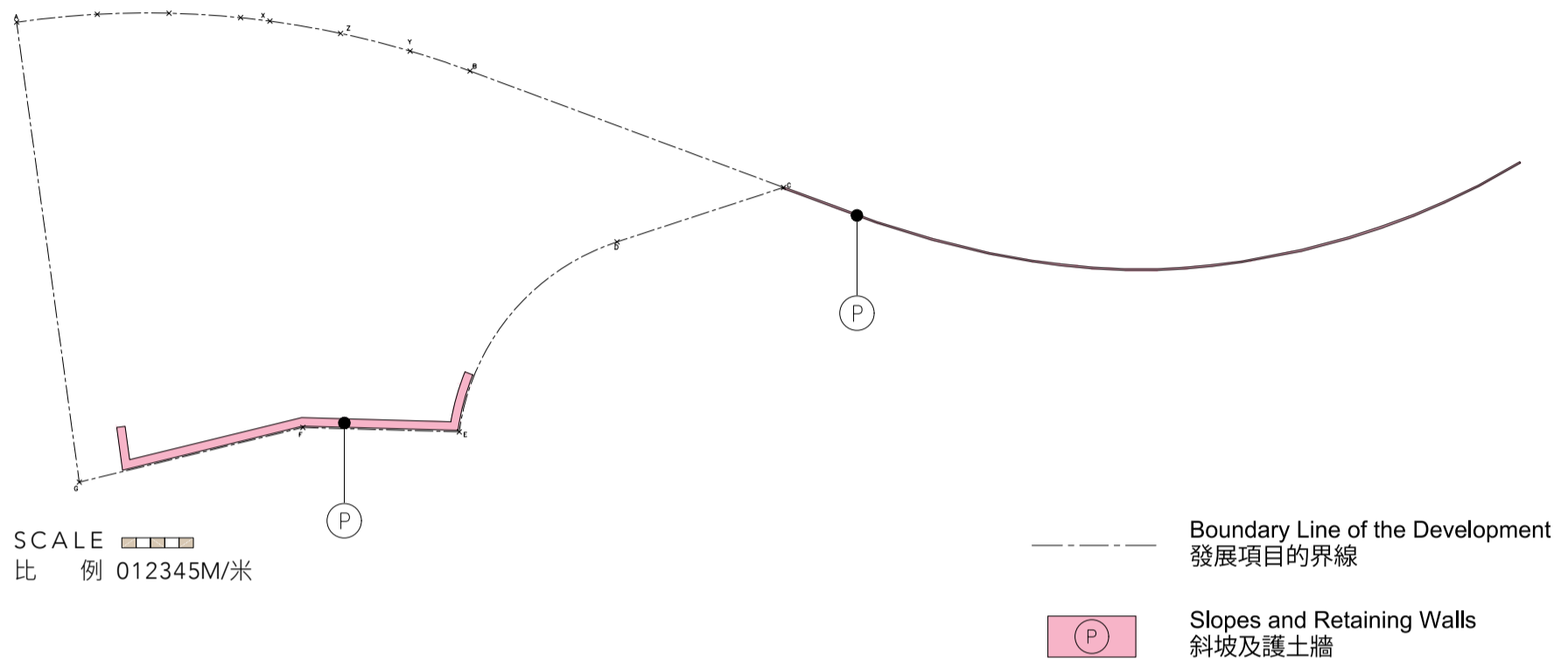

**Remark:**

This plan is for showing the location of the slope and retaining structures areas only. Other matters shown in this plan may not reflect their latest conditions.

1. The Land Grant requires the owners of the residential properties in the Development to maintain any slope at their own cost. The terms of the requirement are as follows:

- (i) Special Condition No.(29)(a) provides that where there is or has been any cutting away, removal or setting back of any land, or any building up or filling in or any slope treatment works of any kind whatsoever, whether with or without the prior written consent of the Director, either within the lot or on any Government land, which is or was done for the purpose of or in connection with the formation, levelling or development of the lot or any part thereof or any other works required to be done by the Grantee under the Conditions, or for any other purpose, the Grantee shall at his own expense carry out and construct such slope treatment works, retaining walls or other support, protection, drainage or ancillary or other works as shall or may then or at any time thereafter be necessary to protect and support such land within the lot and also any adjacent or adjoining Government or leased land and to obviate and prevent any falling away, landslip or subsidence occurring thereafter. The Grantee shall at all times during the term agreed to be granted by the Land Grant maintain at his own expense the said land, slope treatment works, retaining walls or other support, protection, drainage or ancillary or other works in good and substantial repair and condition to the satisfaction of the Director.
- (ii) Special Condition No.(29)(b) provides that nothing in sub-clause (a) of Special Condition No.(29) shall prejudice the Government's rights under the Conditions, in particular Special Condition No.(28).
- (iii) Special Condition No.(29)(c) provides that in the event that as a result of or arising out of any formation, levelling, development or other works done by the Grantee or owing to any other reason, any falling away, landslip or subsidence occurs at any time, whether in or from any land, within the lot or from any adjacent or adjoining Government or leased land, the Grantee shall at his own expense reinstate and make good the same to the satisfaction of the Director and shall indemnify the Government its agents and contractors from and against all costs, charges, damages, demands and claims whatsoever which shall or may be made, suffered or incurred through or by reason of such falling away, land slip or subsidence.
- (iv) Special Condition No.(29)(d) provides that in addition to any other rights or remedies provided in the Land Grant for breach of any of the Conditions, the Director shall be entitled by notice in writing to call

upon the Grantee to carry out, construct and maintain the said land, slope treatment works, retaining walls, or other support, protection, and drainage or ancillary or other works or to reinstate and make good any falling away, landslip or subsidence, and if the Grantee shall neglect or fail to comply with the notice to the satisfaction of the Director within the period specified therein, the Director may forthwith execute and carry out any necessary works and the Grantee shall on demand repay to the Government the cost thereof, together with any administrative or professional fees and charges.

- (v) Special Condition No.(27)(d) provides that the Grantee shall at his own expense uphold, maintain and repair the Brown Area and everything forming a portion of or pertaining to it, all to be done to the satisfaction of the Director, and the Grantee shall be responsible for the whole as if he were the absolute owner thereof.

**Notes:**

- (a) The expression "Grantee" as mentioned in this section means the "Purchaser" under the Land Grant.
  - (b) Unless otherwise specified, terms and expressions as mentioned in this section shall have the same meanings as defined in the Land Grant.
2. Each of the owners is obliged to contribute towards the costs of the maintenance work.
  3. Please refer to the plan in this section for the location of the slope structures, retaining walls or related structures (if any) (the location is coloured in pink).
  4. Under the Deed of Mutual Covenant, the manager of the development has the owners' authority to carry out the maintenance work.

# MAINTENANCE OF SLOPES 斜坡維修

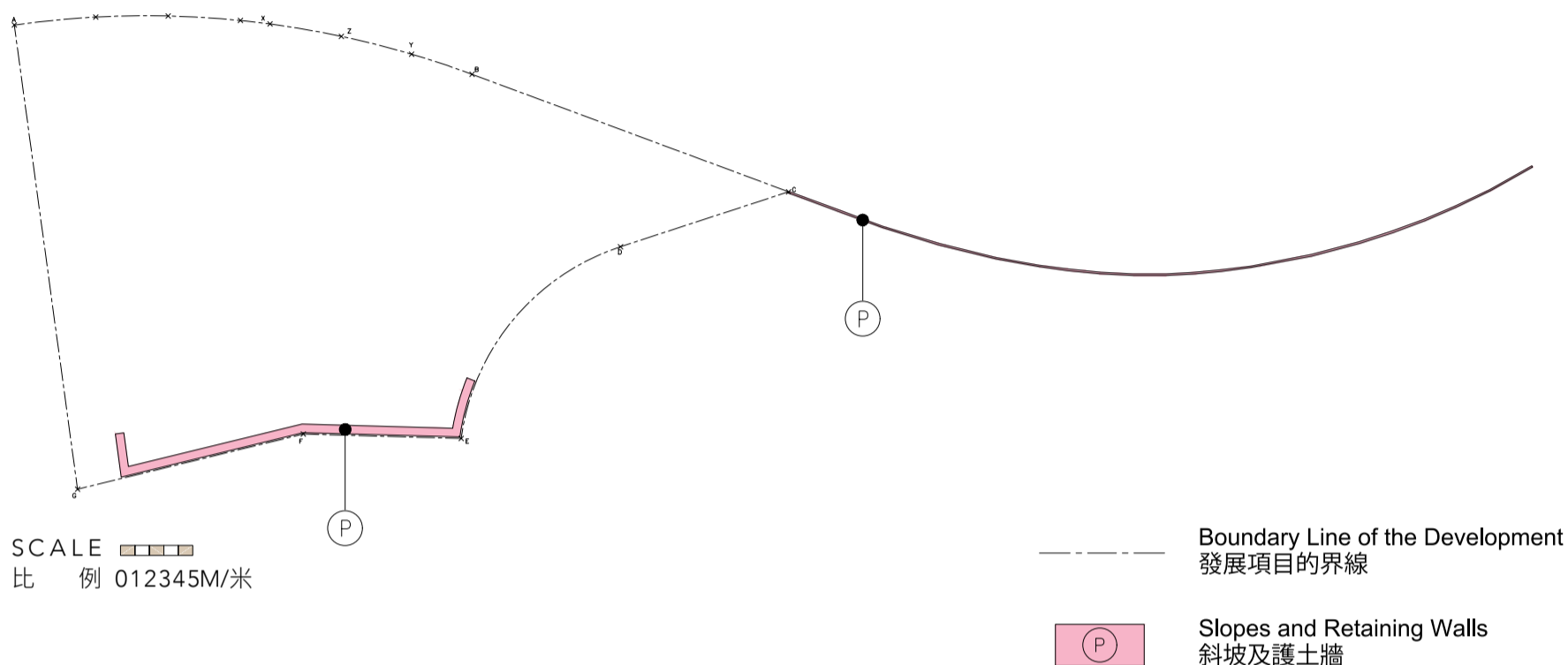

## 備註：

此圖僅作顯示斜坡及護土牆構築物範圍的位置，圖中所示之其他事項未必能反映其最新狀況。

1. 批地文件規定，發展項目中的住宅物業的擁有人須自費維修任何斜坡，該規定的條款如下：

(i) 特別條件第(29)(a)條規定，倘若任何土地遭分割、移除或移後，或倘若任何建造、填土或任何斜坡處理工程經進行(不論有否獲得署長事先書面同意，亦不論是位於該地段內或任何政府土地內，旨在或有關構建、平整或發展該地段或其任何部分或承授人按該等條件須進行的任何其他工程或作任何其他用途)，承授人須自費開展和建設將會或當時或其後任何時間可能需要的斜坡處理工程、擋土牆或其他承托、防護、排水或任何其他附屬工程，以承托及確保該地段及任何毗鄰或毗連政府土地或租用土地內土地的安全，及防止和避免其後出現塌方、山泥傾瀉或地陷的情況。承授人須在批地文件批地年期期間時刻自費維持該地段、斜坡處理工程、擋土牆或其他承托、防護、排水或任何其他附屬工程於修繕妥當及良好的保養狀況，以達致署長滿意。

(ii) 特別條件第(29)(b)條規定，特別條件第(29)(a)條並無損害政府於該等條件下的權利，尤其是特別條件第(28)條下的權利。

(iii) 特別條件第(29)(c)條規定，倘若因為任何構建、平整、發展或承授人進行其他工程或任何其他原因導致任何時候發生塌方、山泥傾瀉或地陷，不論發生在或來自該地段任何土地或任何毗鄰或毗連政府土地或出租土地，承授人須自費進行恢復及修復塌方、山泥傾瀉或地陷，以達致署長滿意，並對上述塌方、山泥傾瀉或地陷造成政府、其代理及承建商承受、遭受或產生的一切費用、收費、損害賠償、要求及索償作出彌償。

(iv) 特別條件第(29)(d)條規定，除了批地文件所規定對違反該等條件的任何其他權利或補償外，署長有權發出書面通知要求承授人進行、興建及保養上述土地、斜坡處理工程、護土牆或其他承托物、保護物及排水系統或附屬工程或其他工程或復原及修復任何塌方、山泥傾瀉或地陷，及倘若承授人不理會或未能在通知指定的時期內執行該通知的要求以達致署長滿意，署長可立即執行與進行任何必要工程，而承授人須在政府要求時償還政府因此產生的費用連同任何行政費或專業費用及收費。

(v) 特別條件第(27)(d)條規定，承授人須自費保養、維修及修理棕色範圍及所有附屬該處和與該處有關的物件，以達致署長滿意。承授人將對該處全部負責，猶如該處的絕對擁有人一樣。

## 備註：

(a) 本節所載的「承授人」指批地文件訂明的「買方」。  
(b) 除另有指明外，本節所載的詞語和詞句與批地文件所定義的一致。

2. 每名擁有人均須分擔維修工程的費用。

3. 斜坡、護土牆或有關構築物(如有)之位置，請參閱本節附圖(位置以粉紅色表示)。

4. 根據公契，發展項目的管理人獲擁有人授權進行維修工程。

## MODIFICATION 修訂

---

No application to the Government for a modification of the land grant for this Development has been made.

就本發展項目並沒有向政府提出申請修訂批地文件。

## RELEVANT INFORMATION 有關資料

---

As at the date of printing of this sales brochure, the respective Vendors of House 1 and House 2 of the Development are both the tenants under two short term tenancies of the Government land for private garden (excluding vehicle parking purposes) adjacent to the Development. The Vendor is not the owner of the short term tenancy private gardens and the short term tenancy private gardens do not form or belong to any part of the Development. No offer, commitment, representation or warranty (whether express or implied) is made by the Vendor in relation to (1) the contents, enforceability, continuity, transferability and whether the purchaser(s) can successfully apply for the short term tenancy(ies) after completion; and/or (2) the short term tenancy private gardens. The above is subject to the terms and conditions of the relevant sale and purchase agreements.

於本售樓說明書印製日期，發展項目中的1號洋房及2號洋房各自的賣方，為毗鄰發展項目作為私人花園(停泊車輛用途除外)的政府土地兩份短期租約下的租用人。賣方並非短期租借私人花園的擁有人，而短期租借私人花園亦不構成或屬於發展項目的任何部份。賣方對(1)短期租約之內容、效力、延續性、可轉讓性及買方在交易完成後能否成功申請短期租約及/或(2)短期租借花園均不作出任何不論明示或隱含之任何要約、承諾、陳述、保證。上述一切皆以有關的買賣合約條款為準。

# INFORMATION IN APPLICATION FOR CONCESSION ON GROSS FLOOR AREA OF BUILDING

## 申請建築物總樓面面積寬免的資料

### Breakdown of GFA Concessions Obtained for All Features

#### 獲寬免總樓面面積的設施分項

Latest information on breakdown of GFA concessions as shown on the general building plans submitted to and approved by the Building Authority (BA) prior to the printing of the sales brochure is tabulated below.

於印製售樓說明書前呈交予並已獲建築事務監督批准的一般建築圖則上有關總樓面面積寬免的分項的最新資料，請見下表。

		Area (m <sup>2</sup> ) 面積(平方米)
<b>Disregarded GFA under Building (Planning) Regulations 23(3)(b)</b> <b>根據&lt;&lt;建築物(規劃)規例&gt;&gt;第23(3)(b)條不計算的總樓面面積</b>		
1	Carparks and loading / unloading areas excluding public transport terminus 停車場及上落客貨地方(公共交通總站除外)	314.561
2	Plant rooms and similar services 機房及相類設施	
2.1	Mandatory feature or essential plant room, area of which is limited by respective Practice notes for Authorized Persons, Registered Structural Engineers and Registered Geotechnical Engineers (PNAP) or regulation, such as lift machine room, telecommunications and broadcasting (TBE) room, TBE room for access facilities for mobile services, rooftop telecommunications equipment room, intermediate telecommunications equipment room, refuse storage chamber, etc. 所佔面積受相關《認可人士、註冊結構工程師及註冊岩土工程師作業備考》(《作業備考》)或規例限制的強制性設施或必要機房，例如升降機機房、電訊及廣播設備室(訊播室)、為流動通訊接達設施而設的訊播室、天台電訊設備室、中層電訊設備室、垃圾房等	3.332
2.2	Mandatory feature or essential plant room, area of which is NOT limited by any PNAP or regulation such as room occupied solely by fire services installations (FSI) and equipment, meter room, transformer room, potable and flushing water tank, etc. 所佔面積不受任何《作業備考》或規例限制的強制性設施或必要機房，例如僅由消防裝置及設備佔用的房間、電錶房、電力變壓房、食水及鹹水缸等	369.970
2.3	Non-mandatory or non-essential plant room such as air-conditioning (A/C) plant room, air handling unit (AHU) room, etc. 非強制性或非必要機房，例如空調機房、送風櫃房等	/
<b>Green Features under Joint Practice Notes 1 and 2</b> <b>根據聯合作業備考第1及第2號提供的環保設施</b>		
3	Balcony 露台	15.832
4	Wider common corridor and lift lobby 加闊的公用走廊及升降機大堂	/
5	Communal sky garden 公用空中花園	/
6	Acoustic fin 隔聲簷	/
7	Wing wall, wind catcher and funnel 翼牆、捕風器及風斗	/
8	Non-structural prefabricated external wall 非結構預製外牆	/
9	Utility platform 工作平台	4.500
10	Noise barrier 隔音屏障	/
<b>Amenity Features</b> <b>適意設施</b>		
11	Caretaker's quarters, counter, office, store, guard room and lavatory for watchmen and management staff and owners' corporation office 管理員宿舍、供保安人員和管理處員工使用的櫃位、辦事處、貯物室、警衛室和廁所，以及業主立案法團辦事處	/
12	Residential recreational facilities including void, plant room, swimming pool filtration plant room, covered walkway, etc. serving solely the recreational facilities 住戶康樂設施，包括僅供康樂設施使用的中空空間、機房、游泳池的濾水機房、有蓋人行道等	/
13	Covered landscaped and play area 有蓋園景區及遊樂場地	/
14	Horizontal screen/ covered walkway and trellis 橫向屏障/有蓋人行道及花棚	/

**INFORMATION IN APPLICATION FOR CONCESSION  
ON GROSS FLOOR AREA OF BUILDING  
申請建築物總樓面面積寬免的資料**

15	Larger lift shaft 擴大升降機槽	/
16	Chimney shaft 煙囪管道	/
17	Other non-mandatory or non-essential plant room, such as boiler room, satellite master antenna television (SMATV) room 其他非強制性或非必要機房，例如鍋爐房、衛星電視共用天線房	/
18	Pipe duct, air duct and vertical riser for mandatory feature essential plant room 強制性設施或必要機房所需的管槽、氣槽及垂直立管	72.062
19	Pipe duct, air duct for non-mandatory or non-essential plant room 非強制性設施或非必要機房所需的管槽及氣槽	/
20	Plant room, pipe duct, air duct for environmentally friendly system and feature 環保系統及設施所需的機房、管槽及氣槽	/
21	Void in duplex domestic flat and house 複式住宅單位及洋房的中空空間	/
22	Sunshade and reflector 遮陽篷及反光罩	/
23	Projecting planters and minor protection such as A/C box, A/C platform, window cill and projecting window 伸出式花槽及小型伸出物，例如空調機箱、空調機平台、窗檻及伸出的窗台	/
24	Other projection such as A/C box and A/C platform not covered in paragraph 3(b) and (c) of PNAP APP-19, and maintenance walkway 《作業備考》APP-19第3(b)及(c)段沒有涵蓋的其他伸出物，如空調機箱及空調機平台，及維修通道	/
<b>Other Exempted Items 其他項目</b>		
25	Refuge floor including refuge floor cum sky garden 庇護層，包括庇護層兼空中花園	N/A 不適用
26	Covered area under large projecting/ overhanging feature 大型伸出/外懸設施下的有蓋地方	/
27	Public transport terminus 公共交通總站	N/A 不適用
28	Party structure and common staircase 共用構築物及公用樓梯	N/A 不適用
29	Horizontal area of staircase, lift shaft and vertical duct solely serving floor accepted as not being accountable for GFA 僅供獲接納不計入總樓面面積的樓層使用的樓梯、升降機槽及垂直管道的水平面積	163.997
30	Public passage 公眾通道	N/A 不適用
31	Covered set back area 有蓋的後移部分	N/A 不適用
<b>Bonus GFA 額外總樓面面積</b>		
32	Bonus GFA 額外總樓面面積	/
<b>Additional Green Features under Joint Practice Note (No. 8) 根據聯合作業備考（第8號）提供的額外環保設施</b>		
33	Building adopting Modular Integrated Construction 採用「組裝合成」建築法的樓宇	/

Note : The above table is based on the requirements as stipulated in the Practice Note for Authorized Persons, Registered Structural Engineers and Registered Geotechnical Engineers ADM-2 issued by the Buildings Department. The Buildings Department may revise such requirements from time to time as appropriate.

備註：上述表格是根據屋宇署所發出的《認可人士、註冊結構工程師及註冊岩土工程師作業備考》ADM-2規定的要求而制訂的。屋宇署會按實際需要不時更改有關要求。

# INFORMATION IN APPLICATION FOR CONCESSION ON GROSS FLOOR AREA OF BUILDING 申請建築物總樓面面積寬免的資料

## Environmental Assessment of the Building

### 建築物的環境評估

**Green Building Certification**

Assessment result under the **BEAM Plus** certification conferred / issued by Hong Kong Green Building Council Limited (HKGBC) for the building prior to the printing of the sales brochure or its addenda.

**FINAL RATING  
UNCLASSIFIED**



Application no.: FAU0017/23

**綠色建築認證**

在印刷此售樓說明書或其附頁前，本物業根據香港綠色建築議會有限公司頒授 / 發出的綠建環評認證評級。

**最終評級  
不予評級**



申請編號: FAU0017/23

## Estimated Energy Performance or Consumption for the Common Parts of the Development

### 發展項目的公用部分的預計能量表現或消耗

Latest information on the estimated energy performance or consumption for the common parts of the Development as submitted to the Building Authority prior to the printing of the sales brochure:

於印製售樓說明書前呈交予建築事務監督發展項目的公用部份的預計能量表現或消耗的最近期資料：

Part I 第 I 部分	
Provision of Central Air Conditioning 提供中央空調	NO 否
Provision of Energy Efficient Features 提供具能源效益的設施	YES 是
Energy Efficient Features installed: 已安裝的具能源效益的設施：	1. LOW LIGHTING POWER DENSITY IN COMMON AREAS. 公用地方低照明功率密度
	2. LIFTS WITH LOW ENERGY CONSUMPTION. 低能源消耗升降機
	3. SPLIT TYPE AIR-CONDITIONERS WITH HIGH COEFFICIENT OF PERFORMANCE. 高效能分體式冷氣機

Part II: The predicted annual energy use of the completed building/ part of the building (Note 1) 第II部分：已竣工樓宇/部分樓宇預計每年能源消耗量(註腳1)：-					
Location 位置	Internal floor area served (m <sup>2</sup> ) 使用有關裝置的內部樓面面積(平方米)	Annual energy use of baseline building (Note 2) 基線樓宇(註腳2)每年能源消耗量		Annual energy use of completed building 已竣工樓宇每年能源消耗量	
		electricity (kWh/m <sup>2</sup> /annum) 電力(千瓦小時/平方米/年)	Towngas/ LPG (unit/m <sup>2</sup> /annum) 煤氣/石油氣(用量單位/平方米/年)	electricity (kWh/m <sup>2</sup> /annum) 電力(千瓦小時/平方米/年)	Towngas/ LPG (unit/m <sup>2</sup> /annum) 煤氣/石油氣(用量單位/平方米/年)
Area served central building service installation (Note 3) 有使用中央屋宇設備裝置的部分(註腳3)	516.5	110.10	0	85.45	0

# INFORMATION IN APPLICATION FOR CONCESSION ON GROSS FLOOR AREA OF BUILDING

## 申請建築物總樓面面積寬免的資料

Part III : The following installations are designed in accordance with the relevant Codes of Practices published by the Electrical & Mechanical Services Department (EMSD) 第 III 部分：以下裝置乃按機電工程署公布的相關實務守則設計：			
Type of Installations 裝置類型	是 YES	否 NO	不適用 N/A
Lighting Installations 照明裝置	√		
Air Conditioning Installations 空調裝置	√		
Electrical Installations 電力裝置	√		
Lift & Escalator Installations 升降機及自動梯的裝置	√		
Performance-based Approach 以總能源為本的方法			√

**Notes:**

1. In general, the lower the estimated "Annual Energy Use" of the building, the more efficient of the building in terms of energy use. For example, if the estimated "annual energy use of proposed building" is less than the estimated "annual energy use of baseline building", it means the predicted use of energy is more efficient in the proposed building than in the baseline building. The larger the reduction, the greater the efficiency. The predicted annual energy use, in terms of electricity consumption (kWh/m<sup>2</sup>/annum) and town gas/LPG consumption (unit/m<sup>2</sup>/annum), of the development by the internal floor area served, where:
  - (a) "total annual energy use" has the same meaning of "annual energy use" under Section 4 and Appendix 8 of the BEAM Plus for New Buildings (v1.2 version); and
  - (b) "internal floor area", in relation a building, a space or a unit means the floor area of all enclosed space measured to the internal faces of enclosing external and/or party walls.
2. "Baseline Building" has the same meaning as "Baseline Building Model (zero-credit benchmark)" under Section 4 and Appendix 8 of the BEAM Plus for New Building (v1.2 version).
3. "Central Building Services Installation" has the same meaning as that in the Code of Practice for Energy Efficiency of Building Services Installations in Buildings.

**註腳：**

1. 一般而言，一棟樓宇的預計“每年能源消耗量”愈低，其節約能源的效益愈高。如一棟樓宇預計的“每年能源消耗量”低於該樓宇的“基線樓宇每年能源消耗量”，則代表預計該樓宇的能源應用較其基線樓宇有效，削減幅度愈大則代表有關樓宇能源節約的效益愈高。  
預計每年能源消耗量[以耗電量(千瓦小時/平方米/年)及煤氣/石油氣消耗量(用量單位/平方米/年)計算]，指將發展項目的每年能源消耗總量除以使用有關裝置的內部樓面面積所得出的商，其中：-
  - (a) “每年能源消耗量”與新建樓宇 BEAM Plus 標準 (1.2 版) 第 4 節及附錄 8 中的「年能源消耗」具有相同涵義；及
  - (b) 樓宇、空間或單位的“內部樓面面積”，指外牆及／或共用牆的內壁之內表面起量度出來的樓面面積。
2. “基線樓宇”與新建樓宇 BEAM Plus 標準 (1.2 版) 第 4 節及附錄 8 中的“基準建築物模式 (零分標準)”具有相同涵義。
3. “中央屋宇裝備裝置”與樓宇的屋宇裝備裝置能源效益實務守則中的涵義相同。

## WEBSITE OF THE DEVELOPMENT 發展項目之互聯網網站

---

The address of the website designated by the vendor for the Development for the purposes of Part 2 of the Residential Properties (First-hand Sales) Ordinance:

[www.theduet.com.hk](http://www.theduet.com.hk)

賣方為施行《一手住宅物業銷售條例》第2部而就發展項目指定的互聯網網站的網址：

[www.theduet.com.hk](http://www.theduet.com.hk)

The date on which this Sales Brochure is printed

12 July 2024

There may be future changes to the Development and the surrounding areas.

本售樓說明書印製日期

2024年7月12日

發展項目及其周邊地區日後可能出現改變。

## EXAMINATION RECORD 檢視紀錄

Examination / Revision Date 檢視 / 修改日期	Page Number 頁次	Revision Made 所作修改
10 October 2024 2024 年 10 月 10 日	15	Aerial photograph of the development is updated. 更新發展項目的鳥瞰照片。
	16	Outline zoning plan etc. relating to the development is updated. 更新關乎發展項目的分區計劃大綱圖等。
	21, 22, 24, 26, 30, 31, 32	Floor plans of residential properties in the development are updated. 更新發展項目的住宅物業的樓面平面圖。
	38	Summary of deed of mutual covenant is updated. 更新公契的摘要。
	40, 41, 43, 44, 45	Summary of land grant is updated. 更新批地文件的摘要。
	48, 49, 50	Information on public facilities and public open spaces is updated. 更新公共設施及公眾休憩用地的資料。
	59, 60, 61, 62, 63, 64, 65, 68, 73, 74, 79, 81, 82	Fittings, finishes and appliances are updated. 更新裝置、裝修物料及設備。
	86	Maintenance of slopes is updated. 更新斜坡維修。
30 December 2024 2024 年 12 月 30 日	16	Outline zoning plan etc. relating to the development is updated. 更新關乎發展項目的分區計劃大綱圖等。
	21, 24, 25, 26, 27, 30, 32	Floor plans of residential properties in the development are updated. 更新發展項目的住宅物業的樓面平面圖。
	73, 74, 75, 76, 77, 78, 79, 80, 81, 82, 82A, 82B, 82C, 82D, 82E, 82F, 82G, 82H	Fittings, finishes and appliances are updated. 更新裝置、裝修物料及設備。
	Examination Record 檢視紀錄	Examination Record is revised. 修改檢視紀錄。
28 March 2025 2025 年 3 月 28 日	14	Location plan of the development is updated. 更新發展項目的所在位置圖。
	15	Aerial photograph of the development is updated. 更新發展項目的鳥瞰照片。
	66	Fittings, finishes and appliances are updated. 更新裝置、裝修物料及設備。
	88, 89	Information in application for concession on gross floor area of building is updated. 更新申請建築物總樓面面積寬免的資料。
27 June 2025 2025 年 6 月 27 日	16	Outline zoning plan etc. relating to the development is updated. 更新關乎發展項目的分區計劃大綱圖等。
	24, 25, 26	Floor plans of residential properties in the development are updated. 更新發展項目的住宅物業的樓面平面圖。
26 September 2025 2025 年 9 月 26 日	9	Information on vendor and others involved in the development is updated. 更新賣方及有參與發展項目的其他人的資料。
	14	Location plan of the development is updated. 更新發展項目的所在位置圖。
24 December 2025 2025 年 12 月 24 日	-	No revision made. 並無作出修改。
24 March 2026 2026 年 3 月 24 日	14	Location plan of the development is updated. 更新發展項目的所在位置圖。
24 March 2026 2026 年 6 月 24 日	14	Location plan of the development is updated. 更新發展項目的所在位置圖。
	15	Aerial photograph of the development is updated. 更新發展項目的鳥瞰照片。



